



Annex

Contents

Parameters, conversions and formulae for technical units of measurement _____	16/2
General information to aid configuration _____	16/4
VEM-Product Range _____	16/28

Parameters, conversions and formulae for technical units of measurement

in SI units of measurement (Système Internationale d'Unité)

Power

1 kW = 1.36 h.p. = 102 kpm/s = 1,000 Nm/s
1 h.p. = 0.736 kW = 75 kpm/s = 736 Nm/s

Work

1 kWh = 3.6 x 10⁶ J = 3.6 x 10⁶ Nm
1 Nm = 0.367 x 10⁶ kpm
1 Ws = 1 J = 1 Nm = 0.102 kpm

Force

1 N = 0.102 kp
1 kp = 9.81 N

Torque

1 Nm = 0.102 kpm = 1 Ws
1 kpm = 9.81 Nm = 9.81 Ws

Pressure

1 Pa = 1 N/m²
1 bar = 10⁵ Pa
1 mm water gauge = 9.81 Pa

Temperature/temperature differences

1 deg = 1 K = 1 °C

Moment of inertia

1 kgm² = 1 Ws³ = 1 Nms² = 0.102 kpm²

Characteristic drive parameters

P_1 ... power input [kW]
 P_2 ... power output [kW]
 P_B ... rated power [kW]
 P ... effective power [kW]
 S ... apparent power [kVA]
 Q ... reactive power [kvar]
 U ... voltage [V]
 U_U ... lower voltage limit [V]
 U_B ... rated voltage [V]
 U_O ... upper voltage limit [V]
 I_B ... rated [nominal] current [A]
 f_B ... rated frequency
 $\cos\varphi$... power factor [-]
 $\cos\varphi_B$... rated power factor [-]
 η ... efficiency [%]
 η_B ... rated efficiency [%]
 n_s ... synchronous speed [rpm]
 n_B ... rated [nominal] speed [rpm]
 M_B ... rated [nominal] torque [Nm]
 M_A ... starting torque [Nm]
 M_S ... pull-up torque [Nm]
 M_K ... pull-out torque [Nm]
 I_A ... starting current [A]
 s_B ... rated slip [%]
 J ... motor moment of inertia [kgm²]

Equivalent circuit data

R_{1w} ... stator winding equivalent resistance at operating temperature in ohms
[at 120 °C winding temperature]
 R_{2w} ... rotor winding equivalent resistance at operating temperature, referred to stator side, in ohms
[at 120 °C winding temperature]
 R_{Fe} ... ohmic equivalent resistance
[also iron equivalent resistance]
 X_{1s} ... stator winding leakage reactance in ohms
 X_{2s} ... rotor winding leakage reactance in ohms,
referred to stator side
 X_{1h} ... stator winding main reactance

Specific quantities

M_A/M_B ... relative starting torque [-]
 M_S/M_B ... relative pull-up torque [-]
 M_K/M_B ... relative pull-out torque [-]
 I_A/I_B ... relative starting current [-]

Drive engineering formulae

Power input

$$P_1 = U \times I \times \cos\varphi \times \sqrt{3} \times$$

Power output

$$P_2 = P_1 \times \eta / 100 \text{ [kW]}$$

Power loss

$$P_V = P_1 - P_2 \text{ [kW]}$$

Effective power

$$P = \frac{P_2 \times 100}{\eta} \text{ [kW]}$$

Apparent power

$$S = \frac{U \times I \times \sqrt{3}}{1000} \text{ [kVA]} \text{ or } S = \frac{100 \times P_2}{\eta \times \cos\varphi} \text{ [kVA]}$$

Reactive power

$$Q = \frac{P_1 \times \tan\varphi \times 100}{\eta} \text{ [kvar]}$$

Current consumption

$$I = \frac{P_w \times 1000}{U \times \cos\varphi \times \sqrt{3}} \text{ [A]} \text{ or } I = \frac{P_2 \times 1000 \times 100}{U \times \eta \times \cos\varphi \times \sqrt{3}} \text{ [A]}$$

Rated slip

$$s_B = \frac{n_s - n_B}{n_s} \times 100 \text{ [%]}$$

Rated torque

$$M_B = 9.55 \times P_B \times \frac{1000}{n_B} \text{ [Nm]}$$

Power demand of selected machines

Lifting movement

$$P = \frac{F \times v}{\eta} \times 10^{-3} \text{ [kW]}$$

Rotating movement

$$P = \frac{M \times n}{9550 \times \eta} \text{ [kW]}$$

Fan drive

$$P = \frac{V \times p}{\eta} \times 10^{-3} \text{ [kW]}$$

Pump drive

$$P = \frac{V \times p}{\eta} \times 10^{-3} \text{ [kW]}$$

P ... power [kW]

F ... force [N]

v ... velocity [m/s]

η ... efficiency

M... torque [Nm]

n ... speed [rpm]

V ... delivery rate [m³/s]

p ... total counterpressure to be overcome [N/m²]

Torques

Conversion of torques for step-down and step-up gearing

$$M_2 = \frac{M_1 \times n_1}{n_2}$$

n_1 ... motor speed [rpm]

M_1 ... motor torque [Nm]

n_2 ... working speed [rpm]

M_2 ... torque at n_2 [Nm]

Moment of inertia

related to rotative moment

$$J = \frac{GD^2}{4}$$

J ... moment of inertia [kgm²]

GD² ... rotative moment [kpm²]

Conversion of moments of inertia to another speed for step-down or step-up gearing

$$J_2 = J_1 \times \left(\frac{n_1}{n_2} \right)^2$$

n_1 ... motor speed

J_1 ... moment of inertia at n_1

n_2 ... working speed

J_2 ... moment of inertia at n_2

Inertia factor

$$F_I = \frac{J_{\text{mot}} + J_{\text{fremd}}}{J_{\text{mot}}}$$

J_{mot} ... moment of inertia of motor [kgm²]

J_{fremd} ... moment of inertia of machine [kgm²]

$$J_{\text{ges}} = J_{\text{fremd}} + J_{\text{mot}}$$

Starting time

$$t_A \approx \frac{J_{\text{ges}} \cdot n_B}{9,55 \times M_{\text{b,m}}} \text{ in [s]}$$

J_{ges} = total moment of inertia to be accelerated in kgm²

n_B = rated speed in rpm

$M_{\text{b,m}}$ = moment of acceleration in Nm

Formulae from acoustics

Sound pressure level

$$L_p = 20 \log \frac{p}{p_0} \text{ [dB]}$$

Reference sound pressure

$$p_0 = 2 \times 10^{-5} \text{ [Pa]}$$

Sound power level

$$L_w = 10 \log \frac{P}{P_0} = L_p + L_s \text{ [dB]}$$

Reference sound power

$$P_0 = 10^{-12} \text{ [W]}$$

Measuring-surface level

$$L_s = 10 \log \frac{S}{S_0} \text{ [dB]}$$

Reference surface

$$S_0 = 1 \text{ m}^2$$

L_p ... sound pressure level [dB]

P ... sound power [Pa]

P_0 ... reference sound pressure [Pa]

L_w ... sound power level [dB]

P ... sound power [W]

P_0 ... reference sound power [W]

L_s ... measuring-surface level [dB]

S ... measuring surface [m²]

S_0 ... reference surface [m²]

General information to aid configuration

1. Torque behaviour and starting current

Fig. 1 shows the characteristic behaviour of torque/current in asynchronous machines for all areas of practical interest.

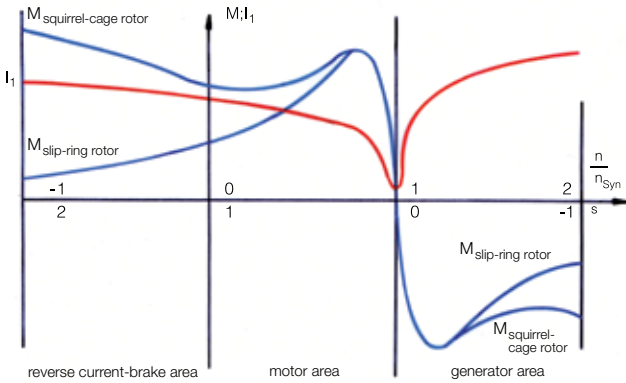

M = Torque
 I₁ = Stator current
 n/n_{Syn} = Ratio speed/synchronous speed
 s = Slip

Figure 1: Characteristic behaviour of torque/current in three-phase asynchronous motors

The torque characteristics of squirrel-cage and slip-ring motors differ significantly in the range $1.2 < n/n_s < 0.8$ due to the specific current displacement effect attributable to the cage design of squirrel-cage motors. By contrast, the characteristic current behaviour of the two machine types is practically identical.

These curves identify characteristic parameters for the motor range of three-phase motors. These parameters are explained in Fig. 2 using the basic characteristic of a squirrel-cage motor.

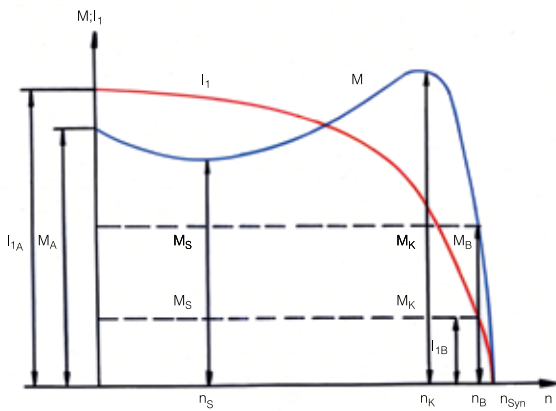

Figure 2: Characteristic behaviour of torque/current in a squirrel-cage motor

- I_A = **Starting current**
 (also known as short-circuit current).
 Max. current drawn by a motor at standstill when supplied with rated voltage/rated frequency in all possible rotor positions after transient reactions have passed.
- M_A = **Starting torque**
 (also known as stalled torque).
 Smallest torque occurring on the shaft end when a motor is supplied with rated voltage/rated frequency in all possible rotor positions after transient reactions have passed.
- M_S = **Pull-up torque** (also known as ramp-up torque).
 Smallest torque occurring on the shaft end of a motor supplied with rated voltage/rated frequency over the range between standstill and sweep speed when speed changes slowly.
- n_S = **Pull-up speed** related to the pull-up torque
- M_K = **Pull-out torque**
 First torque maximum on the shaft end of a machine supplied with rated voltage/rated frequency when speed is slowly reduced starting from synchronous speed.
- M_B = **Rated torque**
- n_B = **Rated speed**
- n_{Syn} = **Synchronous speed**

It is standard practice to relate torque and current quantities to the design data of a motor:

Relative starting current $i_A = \frac{I_A}{I_B}$

Relative starting torque $m_A = \frac{M_A}{M_B}$

Relative pull-up torque $m_S = \frac{M_S}{M_B}$

Relative pull-out torque $m_K = \frac{M_K}{M_B}$

2. Operating characteristics

This is understood to designate the behaviour of essential operating values of a motor over the stable working range between no-load running and outputs in the area of the rated output. These values are normally plotted as a function of output (Fig. 3).

Operating characteristics are an important aid for the evaluation of drives, particularly with regard to partial load and overload behaviour. Partial load values for the power factor $\cos\varphi$ and efficiency η of standard motors can be found in the tables of motor selection data. All other operating values, in particular power output and thus actual load, are easy to determine by measuring the absorbed power or stator current. Operating characteristics for standard motors can be found in our electronic catalogue VEMEKAT; they can also be requested directly from the motor manufacturer.

Essential operating values such as efficiency η and power factor $\cos\varphi$ have been defined in the course of motor design such that an optimum is achieved at rated output P_{2B} .

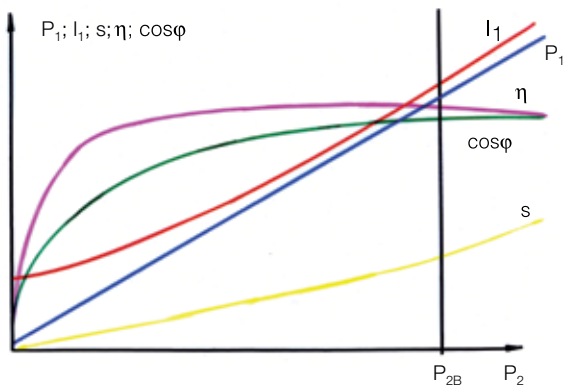

Figure 3: Operating characteristics of an asynchronous motor

Minimum values for the relative pull-out, pull-up and starting torques for three-phase motors are specified in IEC/EN 60034-12.

The actual characteristics achieved by modern standard motors generally far exceed these minimum requirements. Current and torque characteristic data for squirrel-cage motors are given in the technical data, making it possible to predetermine the speed-torque characteristic with sufficient accuracy, for example to judge the starting behaviour of squirrel-cage motors.

While efficiency varies only slightly over a comparatively wide range, a major drop in the power factor must be expected in the partial load range. Figs. 4 and 5 permit corresponding estimations for most cases.

Rated values for operating data can be found in the corresponding technical documentation or else on the rating plate of the motor concerned. Where the efficiency of a motor is not specified on the rating plate, it can be calculated from the standard data as follows:

$$\eta_B = \frac{P_{2B}}{\sqrt{3} \cdot U_{1B} \cdot I_{1B} \cdot \cos\varphi_B} \cdot 100 \%$$

Most operating characteristics specify the slip s , enabling the corresponding speed to be determined as follows:

$$n = n_{Syn} (1 - s)$$

n_{Syn} = synchronous speed

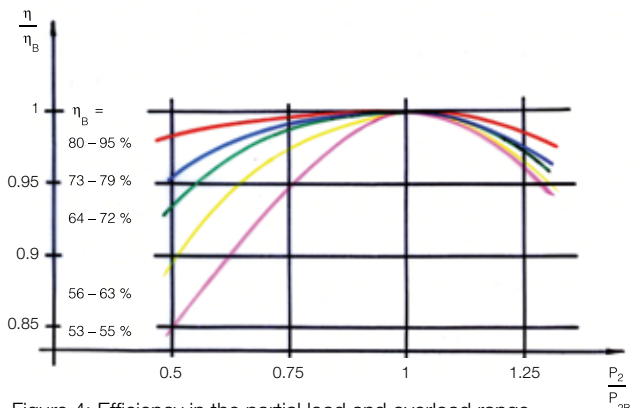

Figure 4: Efficiency in the partial load and overload range

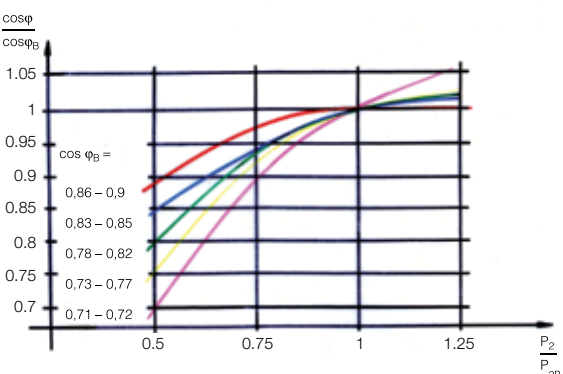

Figure 5: Power factors in the partial load and overload range

3. Pole-changing motors

The mechanical construction of a pole-changing motor corresponds to that of a squirrel-cage motor in its basic version, which means that mounting and assembly dimensions are identical, with the exception of a few versions with three or four speeds, where a larger terminal box is required. In such cases, the dimensions HD (p) and O (r) deviate from the dimensioned drawings for the basic versions.

Pole changing is achieved by appropriate configuration of the stator windings. For motors with two speeds at a ratio of 1:2, a Dahlander winding is preferred. Where other ratios between the two speeds are required, the motor possesses two separate windings. Two windings, one or both of which are designed with Dahlander connection, are needed where a motor has three or more speeds.

Pole-changing motors are designed for direct starting (lowest speed), and higher speeds should normally be reached by going through the lower stages first. For switching back (braking), see the notes given in section 10.

Connecting terminals are designated in accordance with IEC/EN 60034-8.

Examples of terminal connection plans are shown in Fig. 6.

With regard to the individual numbers of poles and speeds, the notes given in section 1 apply equally to pole changing motors, with the exception of the specified minimum values for relative pull-out, pull-up and starting torque, which are expressly exempted from IEC/EN 60034-12.

Pole-changing squirrel-cage motors are suitable for use as machine tool drives, for example. They are able to replace multiple-speed gearboxes or else considerably widen their speed control ranges.

In many drives, they are also a suitable substitute for slipping motors, the advantage being better efficiency at lower speeds. Pole-changing motors combine the basic robustness of squirrel-cage motors with stepped speed control. That is not least the reason why they are used in many special drive applications:

- Lifting gear motors (exact positioning to floor height at low speed, travel at high speed)
- Slide rest adjustment (approach at low speed, retraction at high speed)
- Planers (working pass at low speed, reversing at high speed)
- Pumps, fans, textile machines and similar drives

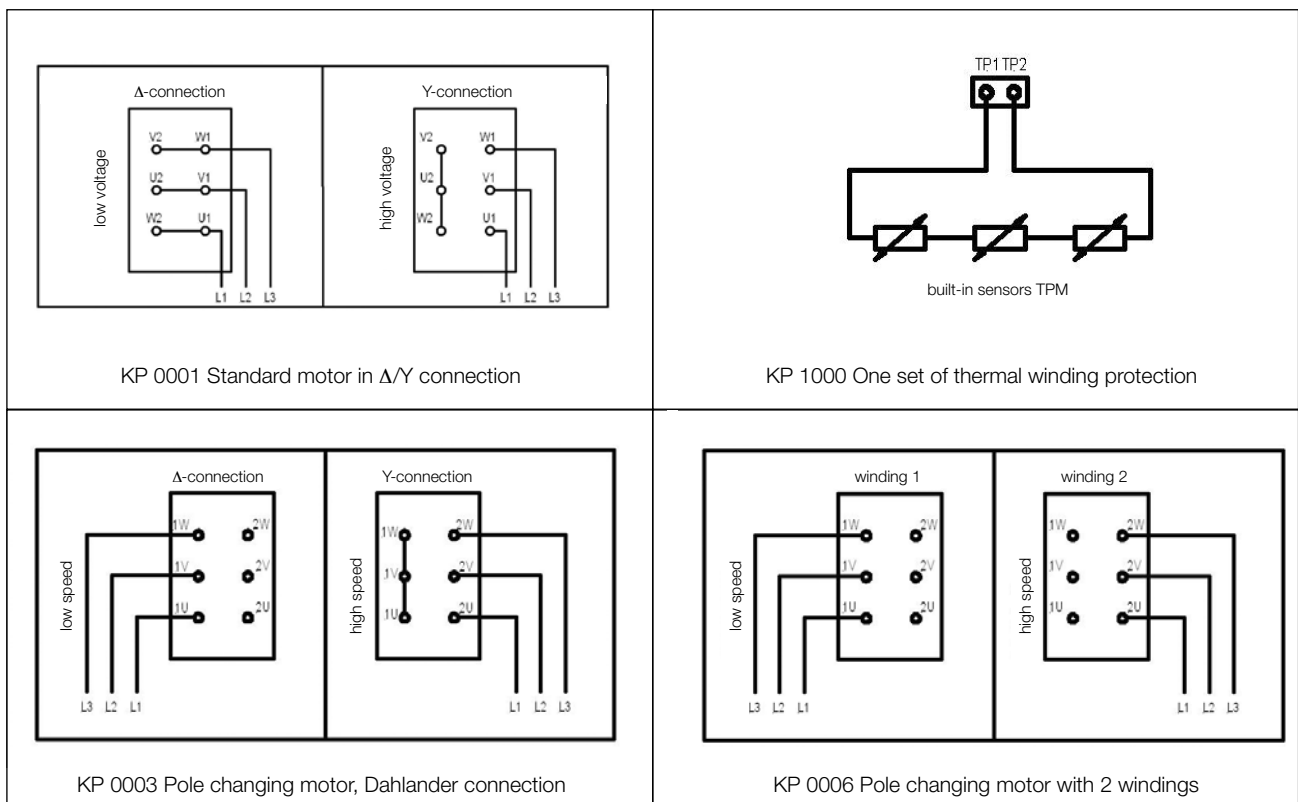

Figure 6: Terminal connection plans (examples)

On an ever growing scale, squirrel-cage motors are fed through a frequency converter for speed control and/or variable-speed operation. Through appropriate programming of the frequency converter, the drive can be configured and adapted optimally for any required speed.

The operating point of a pump or fan drive, for example, can be adjusted to the required flow rate. Compared to volume flow control via regulators or pole-changing motors, this achieves considerable energy savings.

4. Multi-voltage motors

Multi-voltage motors can be operated with the same rated output on mains supplies with different voltages. Their mechanical construction corresponds to that of motors in the basic version, which means that mounting and assembly dimensions are identical, with the exception of a few motor sizes which use larger terminal boxes because they require terminal bases with 9 or 12 terminal studs. In these cases, the dimensions HD (p) and O (r) deviate from the dimensioned drawings of the basic versions.

Voltage switching is achieved by appropriate configuration of the stator windings. The windings are manufactured in two groups, which can then be connected in series or parallel as required. The following voltage combinations are typical:

- **400/690 V in winding configuration Δ/Y**
This is identical to the basic version.
It is suitable for:
400 V for direct or Y/Δ starting
690 V for direct starting only
There is no reduction in output.
- **230/400 V in winding configuration Δ/Y**
similar to 400/690 V in winding configuration Δ/Y
- **230/460 V in winding configuration $\Delta\Delta/\Delta$**
similar to 230/400 V in winding configuration $\Delta\Delta/\Delta$, but without reduced output.

For other voltages, it is necessary to consult the manufacturer.

The use of multi-voltage electric motors is proven above all in mobile applications (e.g. motors for marine use), where operation requires connection to mains supplies with different voltages.

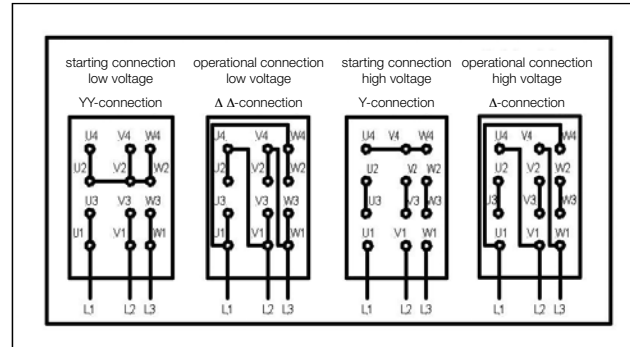

Figure 7: Terminal connection plans for 2 voltages and Y/Δ starting

5. Use of standard three-phase asynchronous motors as single-phase motors

Any three-phase squirrel-cage motor can be operated on a single-phase mains if the required phase shift is produced by an operating capacitor ("Steinmetz circuit"). The circuit is shown in Fig. 8.

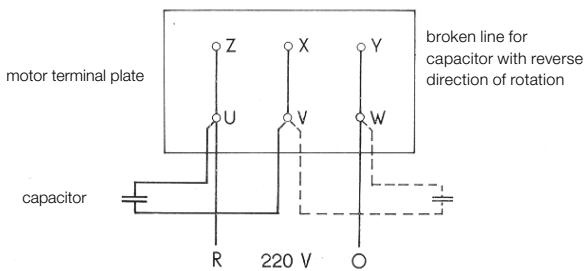

Figure 8: Connection of a 230/400 V three-phase motor as a single-phase motor with operating capacitor

Capacitor size is important for smooth operation. To achieve the required starting torque, a large capacity is needed

for the short-circuit current phase shift. For a phase shift matching the rated operation of the motor, the chosen capacity for the capacitor should not be too large. Starting behaviour is improved if a starting capacitor (which is then switched off after startup) is connected in parallel to the operating capacitor. Selecting a capacitor size from the table below gives the following operating behaviour:

- Output max. 70 % of three-phase output
- Starting torque approx. 20–30 % of the rated torque in single-phase operation

Due to low initial torques and unfavourable main characteristics, these motors can only be used with reduced starting loads, e.g. for fan drives. Motor operating capacitors should normally be designed for continuous operating voltages of 1.2 to 1.5 times the mains voltage, i.e. at least 276 V for a 230 V mains. For other mains voltages, the capacitor size should be calculated as the inverse ratio of the square of the mains voltage.

For technical and economic reasons, the use of a three-phase motor with continuous operating capacitor as a single-phase motor is only meaningful up to a single phase output of around 1 to 2 kW.

Output P_2 for single-phase operation in kW	Capacity C μF	
	at 3,000 rpm	at 1,500 and 1,000 rpm
0.2	16 – 20	20 – 30
0.4	25 – 40	30 – 40
0.6	40 – 50	50 – 60
0.8	60 – 80	70 – 90
1.0	80 – 100	90 – 100
1.2	100 – 120	120 – 140
1.4	120 – 140	140 – 160

6. Selecting a motor

Drive design and the right choice of a motor are instrumental in determining the cost-benefit ratio, avoid setbacks in operation and play a decisive role for economic efficiency. When selecting a motor, all contributing factors such as power demand, operating mode, speed, mains/starting/braking/control conditions, bearing/shaft loads and ambient conditions must be taken into account.

The right choice will often be the basic version. It is therefore assumed for the different operating modes that there is a return to duty type S1 (continuous duty) such that motors are used in the basic mode.

7. Reaction torque, power consumption, moment of inertia

The mechanical power required by a driven machine for continuous duty or at equilibrium in any other operating mode is determined as follows:

$$P_A = \frac{M_g \cdot n_A}{9550} \text{ in kW}$$

where M_g = reaction torque of the driven machine in Nm
 n_A = speed of the driven machine in rpm

For directly coupled drives, this is also the power consumption ($P_A = P_2$) of the motor. If a torque converter (gear unit, belt drive) is placed between the machine and drive motor, the power consumption of the motor is calculated with

$$P_2 = \frac{P_A}{\eta_G} = \frac{M_g \cdot n_A}{9550 \cdot \eta_G} \text{ in kW}$$

where η_G = torque converter efficiency

The aforementioned equations apply only to purely rotational motions. The reaction torque for machines with linear motions must be determined as follows:

$$M_g = 9,56 \cdot \frac{F_A \cdot v}{n_M \cdot \eta_G} \text{ in Nm}$$

where F_A = load in N
 v = speed in m/s
 n_M = motor speed in rpm

The reaction torque and power consumption of a machine are generally a function of the speed. To improve understanding between manufacturers and the users of motors, examples of characteristic reaction torque behaviour are specified and described below (Fig. 9).

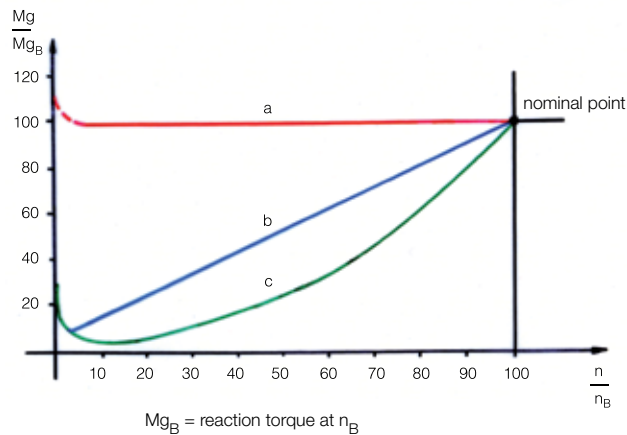

- **Torque practically constant over speed (a)**
 This is the case, for example, for lifting gear, winches, conveyor belts, compressors, when conveying against constant pressures, etc.
- **Linear rise of torque with speed (b)**
 for example for the drives of generators working against constant loads, frequency converters, etc.
- **Torque rises at a specific power (e.g. parabolic) of speed (c)**
 This behaviour is found in the drives of fans, rotary pumps, centrifuges, etc.

Figure 9: Reaction torque characteristics of machines

Other forms of torque behaviour are possible in practice, but these are of lesser importance or else can be traced back to the characteristics explained. Please note that increased friction or adhesion torques may occur at speeds close to zero; such torques are known as breakaway torques and may reach considerable levels (e.g. starting of a piston compressor at low temperatures). These breakaway torques should be known as accurately as possible and must be taken into consideration when assessing starting behaviour.

where J_M = motor moment of inertia
 (to be taken from the technical data of the motor series in question)
 J_F = motor-speed-related sum of moments of inertia of the driven components

Once the moment of inertia of a driven machine has been determined for the speed of the machine using known procedures, the following conversion yields the motor shaft speed:

The total moment of inertia of a drive can be described with

$$J = J_M + J_F$$

$$J_F = \left(\frac{n_A}{n_M} \right)^2 J_A$$

where J_A = moment of inertia of the driven machine at n_A

8. Motor selection for different duty types

This section deals with motor selection on the basis of electric/thermal loads. The decisive parameter when determining motor output is not simply the load at equilibrium. Allowance must also be made for dynamic processes, the final criterion being compliance with a permissible winding temperature rise.

Prerequisite for assignment to a duty type is a load diagram or working cycle showing the torques and outputs to be delivered by the drive, referred to the desired motor speed, over a certain course of time.

8.1. Motor output for continuous duty (duty type S1)

Here, selection is simple because load either does not change or at most fluctuates. The technical data enable selection of a motor with an output equal to or greater than the constant or effective load. The following thus applies for constant load

$$P_{2B} \geq P_A = \frac{M_g \cdot n_A}{9550}$$

where M_g = reaction torque of the driven machine in Nm
 P_{2B} = motor rated output (list output) in kW
 P_A = power consumption of a driven machine in kW
 n_A = machine speed in rpm

If loads fluctuate, the following criteria are used for selection:

$$P_{2B} \geq P_{Am} = \frac{M_{geff} \cdot n_A}{9550}$$

$$\text{where } M_{geff} = \sqrt{\frac{M_1^2 \cdot t_1 + M_2^2 \cdot t_2 + \dots + M_n^2 \cdot t_n}{t_1 + t_2 + \dots + t_n}}$$

M_{geff} = effective reaction torque in Nm
 P_{Am} = mean power consumption of the machine in kW

The individual load portions should be sufficiently small, i.e. $t_n < \tau_1$ or $t_n \ll \tau_2$, where τ_1 and τ_2 stand for the thermal time constants of the motor. If t_n is greater, select the motor according to the highest occurring load portion.

When selecting motors for continuous duty, it is important to ensure that

- the rated output of the selected motors lies as closely as possible above the power consumption, as severely underloaded motors yield poor operating values. On the other hand, there is very little room for overloading due to the high utilisation of modern motors
- attention is given to the starting frequency of the drive. If several start-ups are required per hour, for example, then consultation with the manufacturer may be appropriate, depending on the severity of starting conditions. Design work should follow the rules for switching modes as explained below, as this is no longer S1 operation.

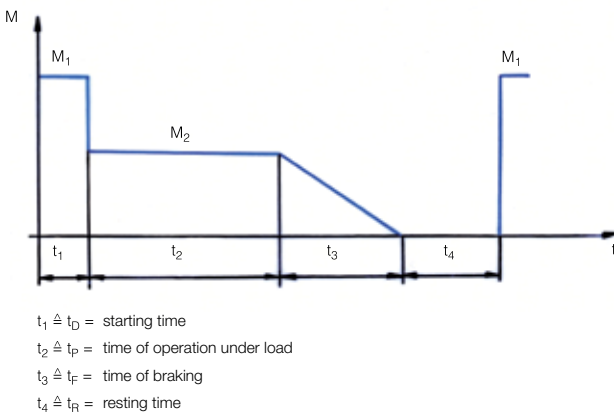

Figure 10: Example of a working cycle

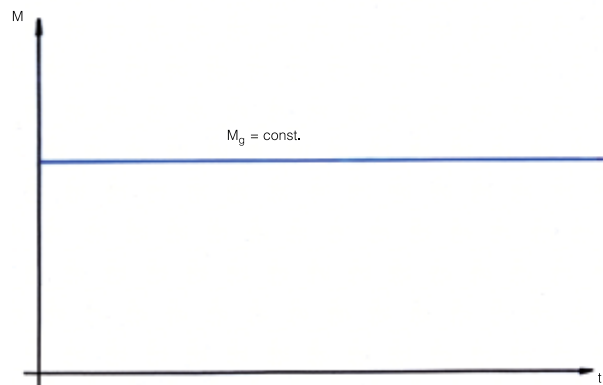

Figure 11: Reaction torque in continuous duty S1

8.2. Motor output in short-time duty (duty type S2)

First use power consumption P_2 for the load phase in S1, as determined from the equations above, to select a motor, then check the corresponding conditions for duty type S2. The following applies:

Operating time $t_p < 3 \cdot \tau_2$
 Interval time $t_R > 3 \cdot \tau_{2St}$

where τ_2 = thermal time constant of the motor in operation
 τ_{2St} = thermal time constant of the motor at standstill (cooling)

In general, the conditions for short-time duty S2 are met by operating periods up to around 60 minutes with correspondingly longer interval times. Preferred values for the operating periods are given in the next table. The permissible output P_{S2} for the selected motor in duty type S2 is determined as follows:

$$P_{S2} = P_{2B} \cdot \sqrt{\left(1 + \frac{K_1}{K_2}\right) \cdot q - \frac{K_1}{K_2}}$$

$$q = \left(1 - \frac{\Theta_2}{\Theta} \cdot e^{-\frac{t_{S2}}{\tau_2}}\right)^{-1}$$

- where q = loss factor
- P_{2B} = motor rated output in S1 according to the technical data
- K_1/K_2 = ratio of no-load to load losses for rated operation of the motor
- Θ_2/Θ = ratio of overtemperature referring to τ_2 to total overtemperature
- t_{2S} = load time in S2

An appropriate motor has been chosen if $P_{S2} \geq P_A$, where P_A represents the actual power consumption. If necessary, repeat the calculation for neighbouring motor sizes.

Output in short-time duty S2 is greater than motor rated output P_{2B} . As a further boundary condition, therefore, consideration must be given to the relative pull-out torque. In accordance with IEC/EN 60034-1, the following applies:

$$\frac{M_K}{M_{BS2}} \geq 1,6$$

where M_K = pull-out torque of the selected motor
 M_{BS2} = rated torque of the motor at P_{S2}

If this requirement is not met, a larger motor must be selected, regardless of the thermal utilisation.

Symbol	Design data	
	Type	Preferred value
S1	Operating time	continuous
S2	Operating time	0.5; 1; 3; 5; 10; 30; 60; 90 min
S3 S6	Period of one cycle	10 min
S4 S5 S7 S8	Switching frequency	60, 90, 120 240, 600 c/h
S3 S4 S5 S6	Relative cyclic doration factor c.d.f.	15 %; 25 %; 40 %, 60 %
S4 S5 S7 S8	Moment of inertia factor FI	1.2; 1.6; 2; 2.5; 4

8.3. Motor output in intermittent pericodic duty (duty types S3, S4, S5, S7)

Knowing that the load diagrams (working cycles) for transient processes may be incomplete, it is advisable to start with a rough motor selection. To this end, the aforementioned effective torque method can be used.

$$M_{geff} = \sqrt{\frac{M_1^2 \cdot t_1 + M_2^2 \cdot t_2 + M_3^2 \cdot t_3 + \dots + M_n^2 \cdot t_n}{t_1 + t_2 + t_3 + \dots + t_n}}$$

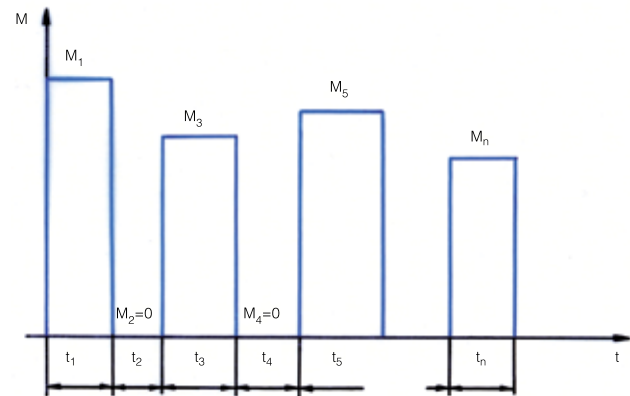

Figure 12: Simplified reaction torque behaviour in intermittent/switching mode

Trapezoidal and triangular sections of the working cycle can be converted to a constant torque during the load phase as follows:

$$M_{Tr} = \sqrt{\frac{M_a^2 + M_a \cdot M_b + M_b^2}{3}}$$

$$M_{Dr} = \frac{M_a}{\sqrt{3}}$$

The approximate output is then determined with

$$P_A = \frac{M_{g\text{eff}} \cdot n_A}{9550} \text{ in kW}$$

Taking into account frequent transient processes, it may already be necessary to select a larger motor. Now, the permissible switching frequency for the selected motor can be calculated under the prevailing conditions:

$$Z_{zul} = \frac{1}{Fl} \cdot f_B \cdot f_S \cdot Z_0 \quad Fl = (J_M + J_F) / J_M$$

where Z_{zul} = permissible switching frequency

Fl = moment of inertia factor

f_B = load factor

f_S = switching factor for the type of connection

Z_0 = no-load switching frequency in c/h

The load factor f_B allows for the cyclic duration factor (c.d.f.) of the drive and the loss factor f_V of the selected motor. It is defined as

$$f_B = (1 - m_g^2) \frac{\text{c.d.f.}}{100\%} + f_V (1 - \frac{\text{c.d.f.}}{100\%})$$

The switching factor f_S makes particular allowance for the type of braking used.

$$f_S = 1 - \frac{m_g}{\bar{m}_A} \quad \text{for switching mode with mechanical braking (e.g. S4)}$$

$$f_S = 1 - \left(\frac{m_g}{\bar{m}_R} \right)^2 \quad \text{for switching mode with counter-current braking or reversing operation (e.g. S5, S7)}$$

$$f_S = 1,08 \frac{(1 + \frac{m_g}{\bar{m}_B})(1 - \frac{m_g}{\bar{m}_A})}{2 + \frac{m_g}{\bar{m}_B} - \frac{m_g}{\bar{m}_A}} \quad \text{for switching mode with DC braking}$$

If the reaction torque during starting and/or ramp-up is less than during operation at rated speed, proceed as follows:

- Calculate the switching factor f_S with the mean relative reaction torque during ramp-up.
- Determine the load factor f_B with the relative reaction torque occurring at rated speed.

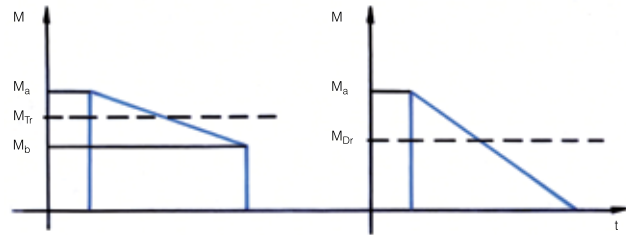

Figure 13: Trapezoidal and triangular reaction torques

In switching modes with mechanical and DC braking, Z_{0A} is used for Z_0 ; in switching modes with counter-current braking and reversal, Z_{0R} is used.

m_g = relative resistance (load) moment referred to the rated torque of the motor

c.d.f. = relative on period in %

f_V = loss factor

\bar{m}_A = mean relative starting torque

\bar{m}_R = mean relative reversing torque

\bar{m}_B = mean relative DC braking torque

To complete the load diagram and for accurate calculation of the relative on period ED, determine the times for transition processes as follows:

$$\text{Starting time } t_D = T_{AN} \frac{Fl}{\bar{m}_A - m_g}$$

$$\text{Reversing time } t_{rev} = 2T_{AN} \frac{Fl}{(\bar{m}_R - m_g)(1 + m_g / \bar{m}_R)}$$

$$\text{Braking time } t_F = T_{AN} \frac{Fl}{\bar{m}_B + m_g}$$

$$\text{where } T_{AN} = \frac{J_M \cdot n_B}{9,55 \cdot M_B} = \text{normal motor starting time in seconds}$$

J_M = moment of inertia of the motor in Nm^2

n_B = rated speed in rpm

M_B = rated torque in Nm

The magnitude of \bar{m}_B depends on the braking circuit used and the level of the exciting current, and cannot be specified as a general value (see also section 10).

Finally, it must be checked that sufficient torque overload capacity is available.

$$\text{The following applies } \frac{M_K}{M_{g\text{max}}} \geq 1,6$$

where M_K = pull-out torque of the selected motor

$M_{g\text{max}}$ = max. reaction torque in the working cycle

Particularly in intermittent duty S3, the effective torque procedure is sufficient to determine the required motor output. As per definition, switching operations need not be taken into consideration here.

$$M_{\text{geff}} = \sqrt{\frac{M_g^2 \cdot t_p}{t_p + t_R}}$$

where t_p = load time
 t_R = interval time

The following then applies for motor selection:

$$P_{2B} \geq P_A = \frac{M_{\text{geff}} \cdot n_A}{9550} \text{ in kW}$$

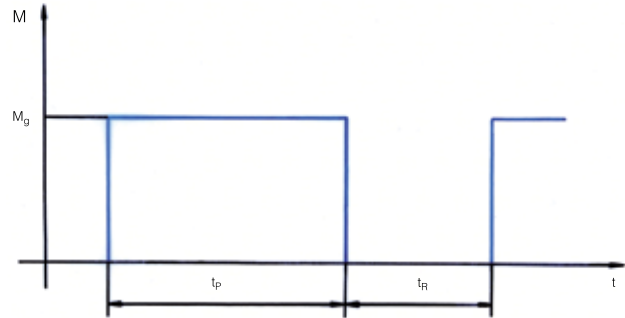

Figure 14: Working cycle in duty type S3

8.4. Motor output in continuous-operation periodic duty (duty type S6)

No general rules can be given regarding selection of a motor for this mode, as the motor size is essentially dependent on the high thermal loads of the given transient processes. It is thus necessary to contact the manufacturer, specifying the following data:

$$M_{\text{geff}} = \sqrt{\frac{M_g^2 \cdot t_p + (f_0 \cdot M_B)^2 \cdot t_v}{t_p + t_v}}$$

where M_g = reaction torque (load)
 M_B = motor rated torque

t_p = load time
 t_v = no-load time
 f_0 = ratio of no-load losses to total losses at rated torque (generally assumed to be 0.4 to 0.5)

An appropriate selection is determined with

$$P_{2B} \geq P_A = \frac{M_{\text{geff}} \cdot n_A}{9550} \text{ in kW.}$$

Checking of the torque overload capacity is performed as described in section 8.3.

8.5. Motor output in continuous-operation periodic duty with realated load/speed changes (duty type S8)

No general rules can be given regarding selection of a motor for this mode, as the motor size is essentially dependent on the high thermal loads of the given transient processes. It is thus necessary to contact the manufacturer, specifying the following data:

- driven machine
- full working cycle (reaction torques and operating times at the specific motor speeds)
- moment of inertia of the driven machine, including transmission elements, with specification of the reference speed
- on period per working cycle and planned switching frequency
- possible braking processes at the end of the working cycle; type of braking, braking torque

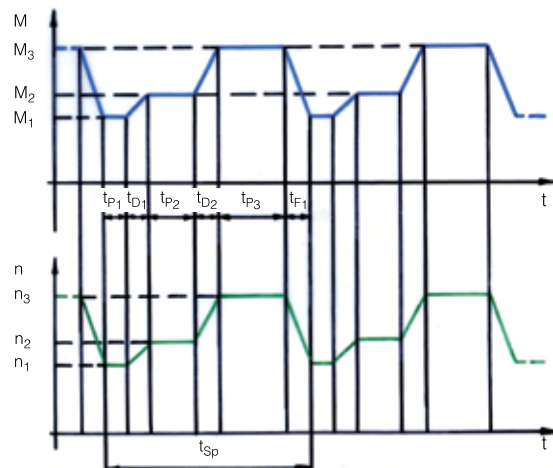

Figure 15: Working cycle in duty type S8

8.6. Operation with non-periodic load/speed changes (duty type S9) and discrete constant loads and speeds (S10)

For this mode of operation, select a constant-load motor to suit mode S1, making allowance for the frequent overloads which arise with this duty type.

9. Squirrel-cage motor starting

Direct starting

In this case, the motor is connected to the mains directly in accordance with its rated voltage. This is the simplest and most reliable type of starting for squirrel-cage motors and should be preferred. The full capacity of the motor is used for ramp-up, and the thermal load is normally kept to a minimum. Direct starting is in fact a must when starting against constant torques or reaction torques which rise steeply with increasing speed, and when accelerating large centrifugal masses (heavy load starting).

With direct starting, the mains must of course handle the full starting current of the motor, which can generally reach 4 to 8 times the motor rated current, depending on the size of the motor and the number of poles. Given today's stable mains, however, it can be assumed that this convenient type of starting can be used almost universally.

The paragraphs below describe a number of procedures for mains and drive conditions which do not allow direct starting.

Star-delta starting

Y/Δ starting is suitable only for motors whose operational winding is connected in Δ, with all 6 winding ends running out to the terminal board (e.g. 230 Δ, 400 Δ, 500 Δ). When starting, the winding is first connected to the mains in star configuration, causing the starting current and starting torque to drop to about 30% of their rated values. After ramp-up to a speed close to the rated speed, the winding is switched over to the operational Δ connection. When using Y/Δ starting, it is imperative to observe the following:

- Since the starting torque has been reduced to about 30 % (applicable to the entire torque behaviour of the motor), it is only permissible to start without load or with a correspondingly low reaction torque, so that sufficient acceleration torque remains available for ramp-up. At each point of the ramp-up curve, the motor torque should be about double the reaction torque applicable at the time, so as to obtain reasonable starting times and to avoid impermissible heating of the motor winding.
- If in doubt, the torque-speed characteristics of a motor can be requested from the manufacturer.

The switchover from Y to Δ must not be triggered before the motor has reached a speed close to rated speed. If switchover is too early, this negates the effect of starting current reduction.

On the other hand, the Y stage should not be prolonged unnecessarily, as this may lead to impermissible heating of the motor windings. The ideal switchover point can be derived after calculation of the starting time (described below), either by testing or by current measurement (for manual switching).

Y/Δ starting can be realised either with manual switches or contactor control. Corresponding circuit diagrams can be found in the technical literature.

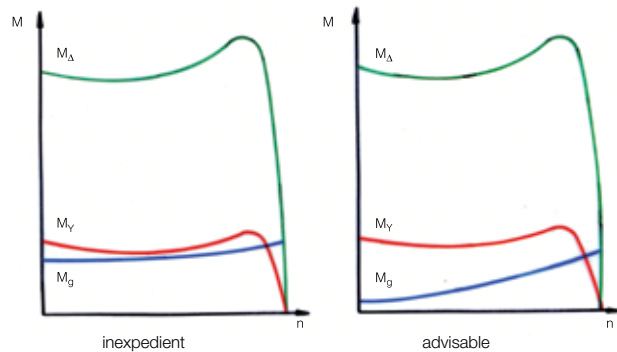

Figure 16: (Un)suitable Y/Δ starting at different reaction torques

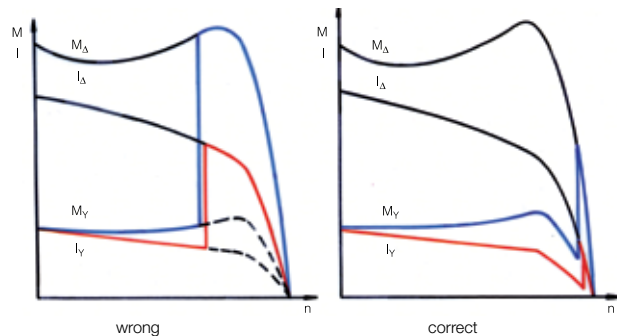

Figure 17: Correct choice of switchover point for Y/Δ connection

Soft starters

The fundamental mode of the motor terminal voltage is controlled via three-phase AC choppers, such that the starting current is reduced. In this way, adjustment to the load characteristic is possible to a certain extent. As the torque is reduced during starting, the notes given for Y-Δ starting also apply for soft starting. Here, too, it is imperative to check the starting behaviour. Torque data for standard motors can be found in the technical data and/or the electronic catalogue VEMeKAT. The related characteristics can also be called up via the electronic catalogue. For special designs, the corresponding data can be requested from the manufacturer.

Starting with frequency converter

During ramp-up in this arrangement, the drive can be accelerated proportionally to the frequency up to rated speed by way of an optimised U/f assignment. During ramp-up with rated current, the rated torque is available over the entire speed range; higher values are possible, depending on the frequency converter used and its individual programming.

Starting time calculation

For many drives, starting time can be determined by way of a mean acceleration torque derived from the torque behaviour of the motor and the reaction torque. The approximate starting time calculated on this basis is

$$t_D \approx \frac{J_{ges} \cdot n_B}{9,55 \times M_{bm}} \text{ in [s]}$$

where J_{ges} = total moment of inertia to be accelerated in kgm^2
 n_B = rated speed in rpm
 M_{bm} = mean acceleration torque in Nm

The starting time is proportional to the total moment of inertia and inversely proportional to the acceleration torque. In this connection, the total moment of inertia J_{ges} for the drive results from the moment of inertia of the motor and the external moment of inertia related to the drive shaft. Mean motor and reaction torques can be derived using suitable procedures for the determination of the arithmetic mean.

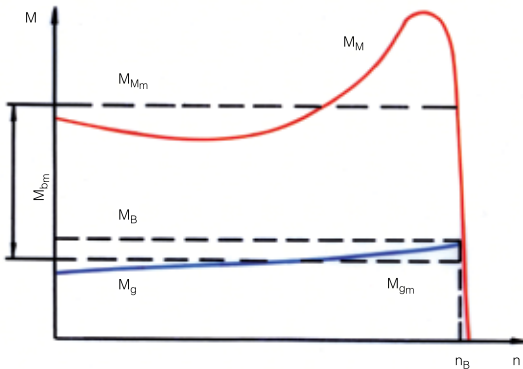

Figure 18: Simplified determination of starting time

For many practical applications, the mean acceleration torque can be determined with sufficient accuracy as follows

$$M_{bm} \approx \frac{M_A + M_K + 4 \times M_S}{6}$$

In certain cases, e.g. special reaction torque behaviours and low acceleration torque, however, this method for starting time calculation is no longer adequate. Starting time should then be determined in steps.

The starting time is calculated with

$$t_D = \sum_{i=1}^{i=n} \Delta t_{D_i} \text{ mit } \Delta t_{D_i} \approx \frac{J_{ges} \cdot \Delta n_i}{9,55 \times M_{bmi}}$$

Δt_{D1} = starting time in section Δn_i in secs
 Δn_i = speed section in rpm
 M_{bmi} = mean acceleration torque in section Δn_i in Nm

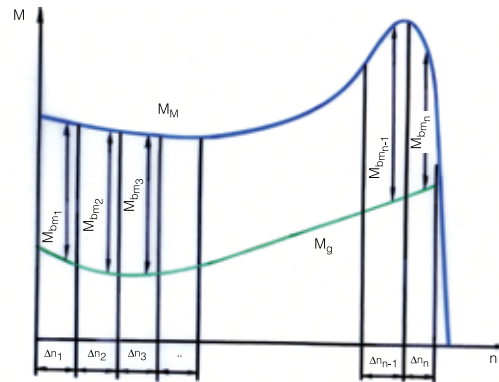

Figure 19: Accurate determination of starting time

The torque behaviour of a squirrel-cage motor can be derived with sufficient accuracy from the values for M_A , M_S and M_K given in the technical data. If necessary, consult the manufacturer for further information.

10. Braking

In certain drive applications, it is not permissible to leave the motor or motor-machine drive unit to handle deceleration and stopping itself. For safety reasons, it is necessary to be able to stop a drive quickly. A drive system can be brought to standstill in a number of ways:

- free coasting to stop
- mechanical braking
- electric braking
- combination of several braking methods (e.g. counter-current braking in connection with a mechanical brake)

Each of these methods has its advantages and disadvantages, and it is thus not possible to give a general recommendation. When designing a drive, the appropriate type of brake should be chosen according to the prevailing operating conditions.

The same technical correlations apply to all braking types, namely that braking time is inversely proportional to the resulting braking torque. The braking time can be calculated with

$$t_f = \frac{J_{ges} \cdot n_B}{9,55 \cdot M_{BrRes}} \text{ in secs}$$

where J_{ges} = total moment of inertia in Nm^2
 n_B = rated speed in rpm
 M_{BrRes} = mean resulting braking torque in Nm

10.1. Free coasting and mechanical braking

The braking torque for these methods stems from the mean reaction torque of the machine, the mechanical losses of the motor, and the mechanical brake. Neither

10.2. Electric braking

With electric braking, the braking torque applied acts in the same direction as the reaction torque of the machine. The resulting braking torque is thus calculated with:

$$M_{\text{BrRes}} = M_{\text{BRM}} + M_g$$

where M_{BRM} = mean acceleration torque

To be able to design a system for electric braking, the following must be known:

- max. occurring load torque
- moment of inertia to be decelerated
- braking time
- speed, switching frequency, voltage, frequency

Electric braking functions without wear or special maintenance. No specific brake is needed, but the switching is more complex.

When designing the system, it must be noted that the motor is additionally subject to thermal load.

Counter-current braking

This form of braking can be used for both squirrel-cage and slip-ring motors. It is realised relatively simply by swapping two of the three three-phase connections. While the centrifugal masses of the drive continue to act in the original direction, the torque already becomes effective in the opposite direction. When the speed reaches zero, the motor must be switched off electrically to avoid a renewed ramp-up in the opposite direction (e.g. by way of a speed monitor). The braking characteristics are dependent on the rotor design.

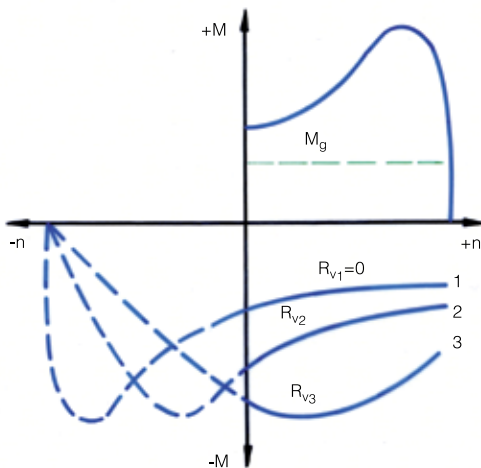

Figure 20: Counter-current braking characteristics

of these two methods affects motor design, as the arising losses place no thermal loads on the motor.

- For squirrel-cage motors

the braking characteristics are dependent above all on the shape of the rotor slot. The assessments found in the technical literature thus range from “modest” to “very powerful” braking action. In practice, testing is advisable.

- For slip-ring motors

the braking characteristics are influenced by the incorporation of additional resistors. Starting and control resistors can be used. The braking effect is greatest where the resistances are changed during braking.

Regarding the thermal loads placed on the motor, it must be noted that the additional warming is around 2 to 3 times that occurring during starting, particularly for squirrel-cage motors, whereas slip-ring motors produce most of the heat externally in the additional resistor. If braking occurs in conjunction with duty type S5, observe the notes given in section 8.3. The duration of occasional counter-current braking should not exceed 10 secs.

DC braking

For this type of braking, the stator of the motor is disconnected from the three-phase mains and subsequently supplied with a direct current after a short interval. The corresponding switching possibilities are shown in Fig. 21. The braking action can be modified by varying the value of the current. The recommended value for the DC braking current is 2 to 2.5 times the motor rated current.

The necessary excitation voltage is calculated with:

$$U_G = I_G \cdot R_{\text{ges}} \cdot 1,3$$

where I_G = excitation current (DC)

R_{ges} = total resistance after a short interval

(Fig. 21)

R_{Ph} = phase resistance (Fig. 21)

The braking characteristic can be derived point by point from the motor characteristics $M = f(n)$ and $I_1 = f(n)$.

The braking torque is calculated with:

$$M_{\text{Br}} = M \left(\frac{K \cdot I_G}{I_1} \right)^2$$

where M = motor torque

K = braking circuit factor (Fig. 21)

I_1 = motor current

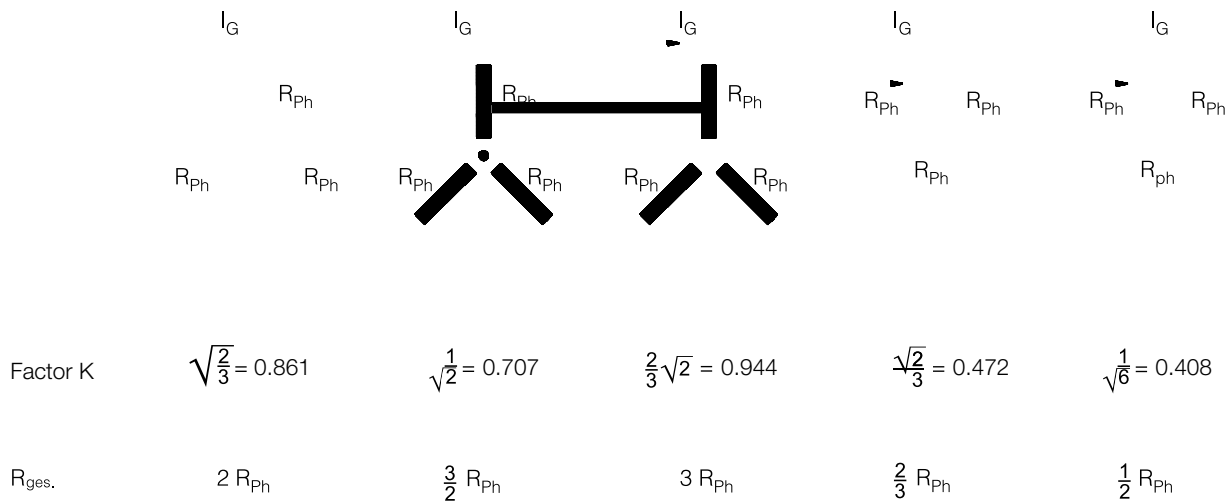

Figure 21: Winding circuits for DC braking

The braking action is gentler than in counter-current braking, there are no shocks acting on the gear unit and/or coupling, and there is no subsequent starting in the opposite direction. Additional mechanical braking may be required towards the end of the braking process. Whether braking is better with DC or counter-current braking can only be decided for an individual case. It is without doubt, however, that DC braking offers a thermal advantage, because the resulting losses are approximately the same as for starting. In case of DC braking in duty type S5, the notes given in section 8.3 must be observed for design.

Supersynchronous braking

Three-phase asynchronous motors operate in the supersynchronous range if

- a passing load accelerates the motor beyond its synchronous speed
- the mains frequency is suddenly reduced, or
- a pole-changing motor is switched from a higher to a lower speed.

Transition to the generator range causes a braking effect above the synchronous speed, though there is no braking to standstill.

Fig. 23 shows the braking characteristics for a two-speed pole-changing motor. If the lower speed is already quite low, absolute standstill can be achieved with subsequent mechanical braking. For supersynchronous braking, it is advantageous that the generator braking torques are greater than the torques in motor operation. Further influence is possible by way of an additional rotor resistance or changes in the stator winding circuit.

When a pole-changing motor is switched back from a higher to a lower speed, the resulting braking torques may far exceed the rated torque for a short period. It may be possible to reduce this braking torque by switching back via the "0" stage, if necessary with a delay.

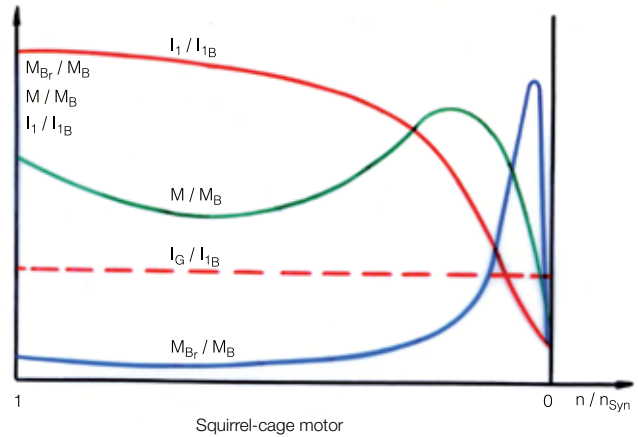

Figure 22: Characteristics for DC braking of a squirrel-cage motor

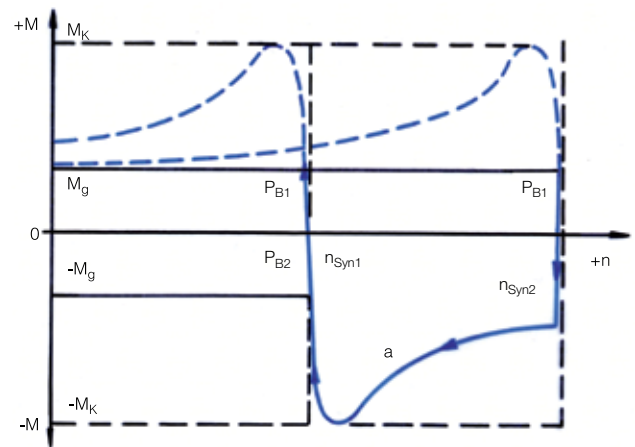

Figure 23: Supersynchronous braking

Subsynchronous braking

Subsynchronous braking arrangements are used exclusively with slip-ring motors. Their primary field of application is in crane operations. For such applications, it is imperative that two phases of the motor are always connected to the mains in order to prevent a free-wheeling situation. The following possibilities are known:

– **Single-phase braking circuit or subsynchronous counter-torque lowering:**

The three phases are interconnected as shown in Fig. 24 and together connected to two line conductors. The rotor is connected to a three-phase resistor.

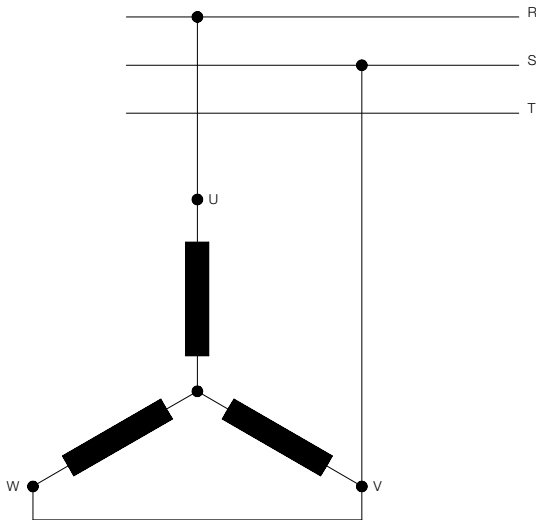

Figure 24: Single-phase braking circuit for the stator winding

– **Double motor circuit:**

Two three-phase machines work together, one as a drive motor, the other as a braking generator.

– **Asymmetrical three-phase braking circuit**

(Fig. 25):

Here, the double motor circuit is incorporated into one machine. The beginning and end connections of one phase of the delta-connected stator winding are swapped.

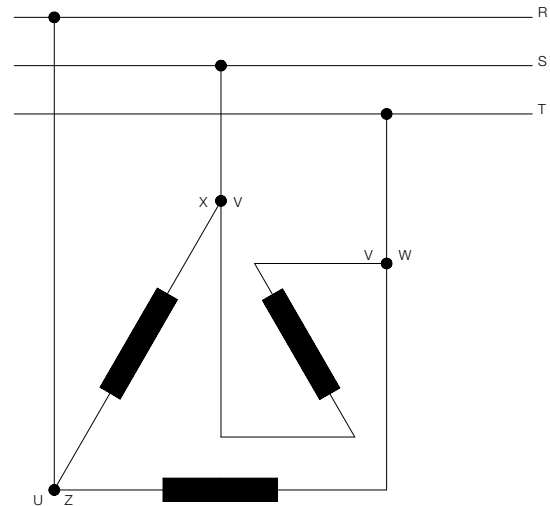

Figure 25: Asymmetrical three-phase braking circuit

11. Generators

When an asynchronous machine exceeds its synchronous speed, it goes into generator operation. The drive torque may be supplied by a hydraulic motor, diesel unit, etc. The amount of the torque depends on the amount of supersynchronous slip and, in the same way as the torque in motor operation, possesses a maximum which is slightly greater than the motor pull-out torque.

The operation of a squirrel-cage motor as an asynchronous generator requires a live mains connection or else excitation via capacitors to supply the reactive current required for magnetisation.

In mains operation, the frequency and voltage of the generator match the parameters of the mains. The active power output depends only on speed, which is automatically adjusted to the available drive power unless the drive torque exceeds the generator pull-out torque. The speed

lies approx. 1 to 3 % above the synchronous speed. When working with connection to the public grid, appropriate feed-in conditions must be discussed with the utility company in advance. Further details can be found in the "Technical Requirements for Connection to the Low-Voltage Grid" (TAB 2000).

In isolated operation, the magnetisation current is drawn from capacitors, whose size depends on the reactive power consumption of the generator and the size and type of consumers to be supplied. In addition, the dielectric strength of the capacitors should be set to the peak value of the voltage produced in the given circuit. Careful design is here imperative, as the system (generator – capacitor – load) reacts to speed and load changes with strong fluctuation of the voltage and frequency.

12. Mechanical transmission elements

To ensure smooth and shock-free running, the place of installation of the motor must be chosen carefully. It should stand on an exactly level surface, and the transmission elements to be mounted on the shaft end should be (dynamically) balanced. If this is neglected, the (antifriction) bearings will suffer additional loads and damage.

Motor output is generally transmitted to the machine via

- couplings
- belts
- chains
- gears.

It is up to the designer to find the optimum solution for a particular drive application, taking into account all structural and economic factors.

Generally speaking, the outer contours of the transmission elements to be mounted on the motor shaft end must never project beyond the shaft end shoulder, and only standard transmission elements should be used. If self designed parts must be used as an exception, they must nevertheless meet all requirements of the applicable stan-

12.1. Coupling drives

Direct couplings are used for most driving and driven machines. Only flexible or special elastic positive couplings should be used. Couplings require very careful aligning of individual machines, i.e. the shaft centres must stand in precise alignment.

Certain inaccuracies in the individual machines may be compensated by the coupling, depending on the type of coupling chosen, but they will nevertheless place considerable loads on the bearings and shafts and result in uneven/unsteady running. The result will be greater or lesser destruction of the bearings, motor shafts and transmission elements of couplings. The better the alignment of machines connected by couplings, the lower the extra loads to be expected and the greater the functional reliability.

Rigid couplings should always be avoided, as they are unable to compensate even the slightest misalignment. As the warming of a cold motor to operating temperature necessarily leads to linear expansion of the shaft, the use of a rigid coupling can already destroy the bearings of the motor or the driven machine after just a short time, and is therefore not authorised by the motor manufacturer.

12.2. Belt drives

Belt drives are used mainly where

- the driving and driven machines must run at different speeds,
- the shafts are not in one plane,
- flexible power transmission is needed,
- shock and vibration damping is to be achieved.

The most commonly used belts are flat and V-belts in a variety of designs and materials. The preference for one or the other of the two types is dependent on their specific properties and is dealt with in the technical literature.

The following points must be observed when designing belt drives:

- Belt pre-tensioning must be adjustable. e.g. by way of tensioning bars, rolls or rockers.
- The shafts of the driving and driven machines must be exactly parallel.
- Where several belts are used on a pulley, endless belts are recommended. Such belts should be kept in stock and similarly replaced, when necessary, in sets.

dards with regard to manufacturing accuracy, balancing, limits of use, etc.

The following sections describe the effects of drive element masses and forces (F_G in N) on the radial (F_r) and axial forces (F_a) for horizontal and vertical shafts. Where the angle of the motor axis is inclined $>15^\circ$ relative to the horizontal/vertical, the force (F_G) generated by the mass of the drive elements must be apportioned geometrically to F_r and F_a .

When using torsionally flexible couplings (plate or bolt couplings), it must be noted that the coupling and the masses it connects form a vibrating system with a certain natural frequency. This natural frequency is reduced by softer couplings and increased by harder ones. Where drives are subject to periodic shocks, it must be ensured that the frequency of the shock moments does not coincide with the natural frequency. Resonance or near-resonance may result in greater vibration amplitudes and loads in the system.

The size of a coupling is selected on the basis of the rated torque on the motor shaft.

$$M_B = \frac{9550 * P_{2B}}{n_B}$$

where M_B = motor rated torque [Nm]
 P_{2B} = motor rated output [kW]
 n_B = rated speed [rpm]

Operational loads must be taken into account by selecting a coupling of an appropriate size.

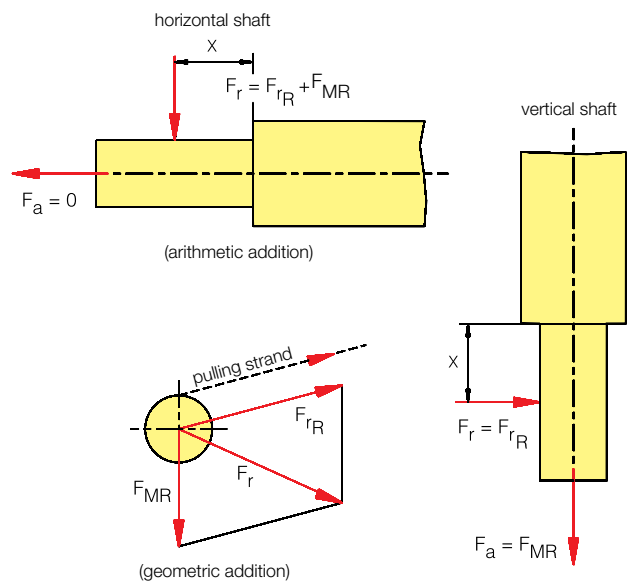

Figure 26: Shaft loading in belt drives

If the aforementioned measures are observed, uncontrolled reduction of the belt service life of belt systems can be avoided, and premature damage to the driving and driven machines due to uncontrolled loads on the shaft ends and bearings can be averted.

Determining the pulley dimensions

Pulleys must be dimensioned such that the permissible values for F_r and F_a on the shaft end are not exceeded. The radial force F_{rR} in belt drives is composed of the pull and the pre-tensioning of the belt. The latter is taken into account with the factor c_v when determining F_{rR} .

Approximate values are

- 2...2.5 for V-belts
- 2.5...3 for standard flat leather belts with tensioning rolls
- 4...5 for standard flat leather belts, rubber belts, etc. without tensioning rolls

The radial force for a given pulley can be determined with

$$F_{rR} = 2 \cdot 10^7 \frac{P_{2B} \cdot c_v}{n_B \cdot D}$$

12.3. Chain drives

Contrary to a belt drive, a chain drive represents a positive transmission element with no slip, even in case of short distances between the axes and high transmission ratios. Compared with gear drives, chain drives are to some extent elastic and are also able to span larger distances between axes without intermediate sprockets.

The radial force acting on the motor shaft end can be determined with

$$F_{rKe} = 2 \cdot 10^7 \frac{P_{2B}}{n_B \cdot D} \cdot c_k \cdot c_d$$

where F_{rKe} = radial force [N]
 P_{2B} = motor rated output [kW]
 c_k = factor taking into account the additional force arising in chain drive itself

where F_{rR} = radial force [N]
 P_{2B} = motor rated output [kW]
 c_v = belt pre-tensioning factor
 n_B = motor rated speed [rpm]
 D = pulley diameter [mm]

The inertia force is calculated as follows:

$$F_{MR} = m_R \times g$$

where F_{MR} = inertia force [N]
 m_R = pulley weight [kg]
 g = gravitational acceleration [9.81 ms⁻²]

Geometric addition is possible for very large pulleys. The effective direction of F_{rR} is invariably towards the driving side. The shaft loads F_r and F_a result as shown in Fig. 28. The dimension x is the distance from the pulley centre to the shaft shoulder. The values F_r , F_a and x can be used to check on the permissibility of loads in accordance with the "Technical explanations".

If the permissible load is exceeded and no significant modification of the load is achieved by choosing a different belt with different pre-tensioning, a pulley with a larger diameter must be selected.

c_d = factor taking into account the additional force emanating from the machine
 n_B = motor rated speed [rpm]
 D = reference circle diameter of the chain wheel used [mm]

The effective direction of F_{rKe} is always towards the driving side.

On motors with horizontal shafts $F_a=0$, on vertically oriented motors $F_a=F_{MKe}$. F_r , F_a and x and determined in the same manner as described in Fig. 28.

$$F_{MKe} = \text{inertia force of the chain wheel [N]}$$

If the permissible shaft load is exceeded, reference circle diameter of the chain wheel must be increased.

No. of engagements	Type of teeth	Factor c_k
1	Precision gear wheels (pitch errors/form defects < 0.02 mm)	1.05 ... 1.1
	Standard planed/milled gear wheels and chain wheels (error 0.02–0.10 mm)	1.1 ... 1.3
	Standard planed/milled gear wheels and chain wheels (error 0.02–0.10 mm)	1.5 ... 2.2
2	Precision gear wheels	0.6 ... 0.7
	Standard planed/milled gear wheels	0.7 ... 0.8
The lower values apply at low tooth speeds of $v \leq 2$ m/s		

Factor c_k for chain and gear drives

Type of machine	c_d
Prime movers	
Electric machines, turbines	1.0 ... 1.1
Electric traction motors in locomotive frames	1.1 ... 1.2
Axle-hung electric traction motors, combustion engines, piston steam engines	1.2 ... 1.5
Transmission systems for driving larger groups of machines	
	1.1 ... 1.3
Conveyors, lifting gear	
Conveyor belts, ropeways, centrifugal pumps, blowers, turbocompressors	1.0 ... 1.2
Mine fans	1.1 ... 1.3
Elevators, cranes	1.2 ... 1.3
Piston compressors	1.2 ... 1.5
Reciprocating pumps, depending on balancing	1.5 ... 1.6
Hoisting equipment	1.5 ... 1.8
Oscillating conveyors	1.5 ... 2.5

Factor c_d for chain wheel/gearwheel drives

12.4. Gear drives

Gear drives transmit outputs and speeds without slip and are used above all where the distance between the axes of the driving and driven machines is small and different speeds are required.

Generally, it is possible to distinguish

- straight spur gears, where only radial forces arise in power transmission
- helical spur gears, bevel gears, etc., where both radial and axial forces occur in power transmission

Straight spur gear drives

The radial force F_{rZg} is determined with

$$F_{rZg} = 2 \cdot 10^7 \cdot \frac{P_{2B}}{n_N \cdot D_T} \cdot c_k \cdot c_d$$

where F_{rZg} = radial force [N]

P_{2B} = motor rated output [kW]

c_k = factor taking into account the additional force arising in gear drive itself

c_d = factor taking into account the additional force emanating from the machine

n_B = motor rated speed [rpm]

D_T = reference circle diameter of the gear wheel used [mm]

The effective direction of the radial force F_{rZg} is shown in Fig. 27.

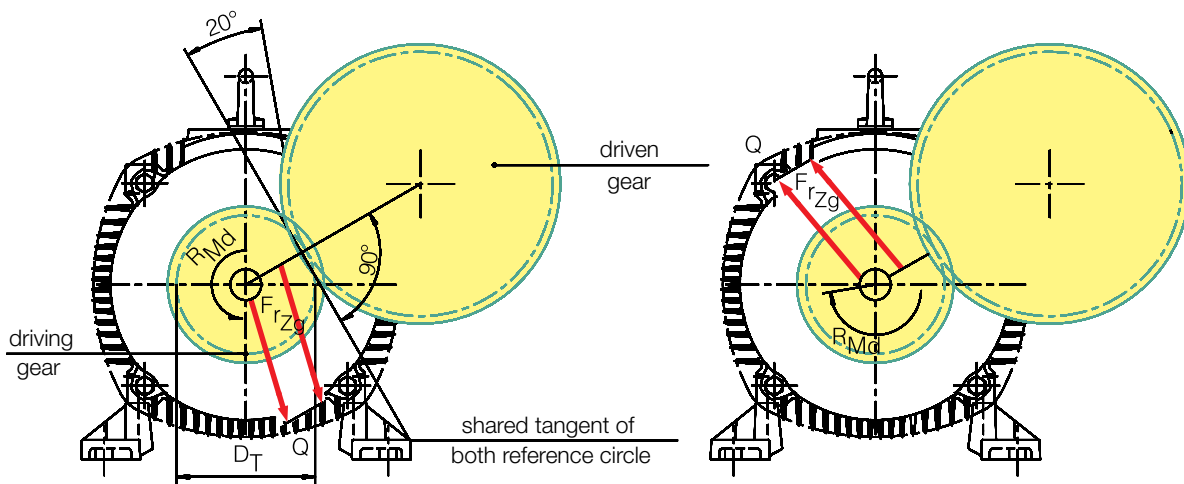

Figure 27: Effective direction of radial force in spur gears

The radial force F_{rZg} for spur gears always acts under 20° to the joint tangent of the reference circles of the driving and the driven gear.

The following load diagrams take into account the inertia force of the gear F_{MZ} :

For gears with high inertia forces, F_{rZg} and F_{MZ} can also be added geometrically.

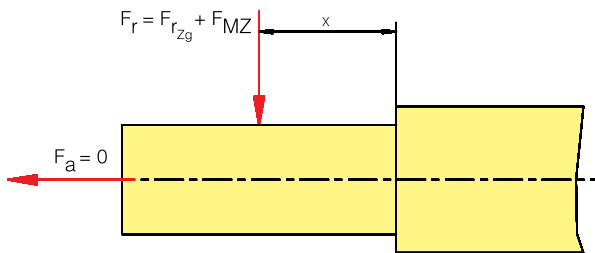

Figure 28: Mechanical drive for a horizontal shaft (straight spur gears)

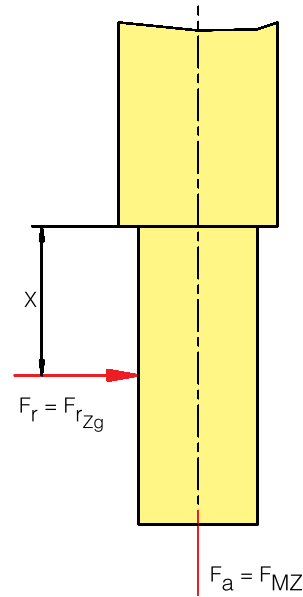

Figure 29: Mechanical drive for a vertical shaft (straight spur gears)

Helical spur gear drives

With helical spur gears, radial and axial forces always occur together, though the latter do not act in the motor shaft axis.

Where bevel gears, etc. are used, it is also necessary to consult the motor manufacturer and to provide similar values as for helical spur gears.

The following points must always be observed for gear drives:

- The shafts of the two machines must be exactly parallel.
- The pinion and mating gear must run absolutely true.
- The pinion teeth must not seize in any position of the mating gear.

If these points are neglected, inadmissible bearing loads, vibration, shocks and disturbing noise must be expected. If a paper strip of the same width as the pinion and mating gear is inserted between the two, turning of the gears will reveal any points of misengagement. It must be ensured that all teeth of both wheels are tested in this way. In accordance with the test results, the machine must be realigned as often as is necessary to achieve uniform smooth engagement for all teeth.

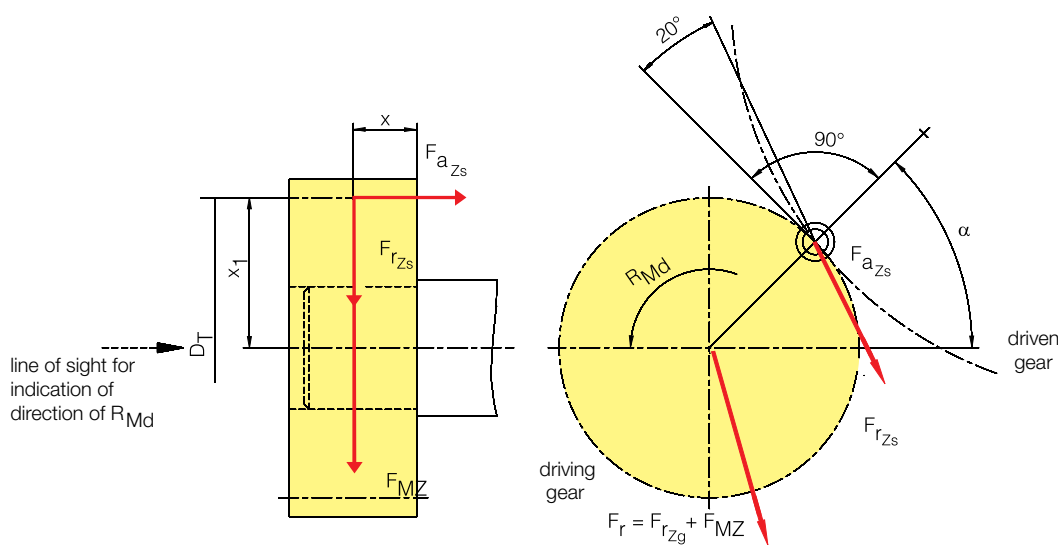

Figure 30: Application of force in helical spur gears with corresponding explanations

13. Slip-ring rotors

13.1 Slip-ring motor starting

Slip-ring motors are started almost exclusively by way of a starter which places additional resistors in the rotor circuit.

The starting torque can be varied freely through corresponding dimensioning of the starting resistor. The highest attainable starting torque lies at the level of the pull-out torque of the motor; the permissible tolerances for the pull out torque in accordance with IEC/EN 60034-1 must be observed.

The rotor voltage at standstill and the rotor rated current, which are required for determination of the appropriate starting resistors, can be taken from the applicable technical data. If the actual power consumption deviates from the list output, the rotor current can be recalculated as follows:

$$I_2 = I_{2B} \frac{P_2}{P_{2B}}$$

where I_2 = rotor current for actual power consumption
 I_{2B} = rotor rated current
 P_2 = actual power consumption
 P_{2B} = rated output

The rotor current which occurs during starting is approximately proportional to the available starting torque and can thus be determined with:

$$I_{2A} = I_{2B} \frac{M_A}{M_B}$$

where I_{2A} = starting current in rotor
 M_A = starting torque
 M_B = motor rated torque

The total value of the additional resistors for the rotor circuit is calculated as follows:

$$R_V = \frac{U_{20}}{\sqrt{3} \cdot I_{2B}} \cdot \frac{M_B}{M_A} - R_2$$

13.2.2. Electric braking

With electric braking, the braking torque applied acts in the same direction as the reaction torque of the machine. The resulting braking torque is thus calculated with:

$$M_{BrRes} = M_{Brm} + M_g$$

where M_{Brm} = mean braking torque

To be able to design a system for electric braking, the following must be known:

- max. occurring load torque
- moment of inertia to be decelerated
- braking time
- speed, switching frequency, voltage, frequency

Electric braking functions without wear or special maintenance. No specific brake is needed, but the switching is more complex.

When designing the system, it must be noted that the motor is additionally subject to thermal load.

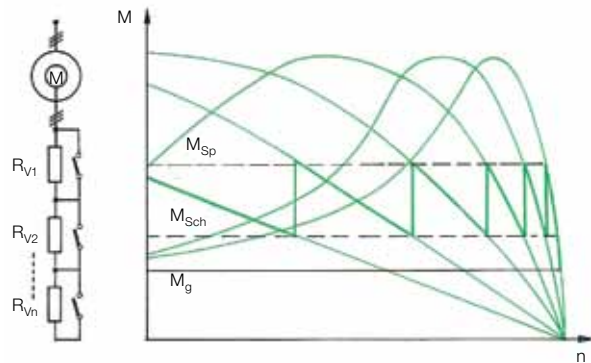

Figure 31: Starting of slip-ring motors with additional resistors in the rotor circuit

where U_{20} = rotor voltage at standstill (from technical data)
 R_2 = equivalent resistance

For crane motors with slip-rotors, R_2 is specified in the technical data. Otherwise, R_2 can generally be neglected. If necessary, it can be requested from the manufacturer or calculated in approximation with:

$$R_2 \approx \frac{U_{20}}{\sqrt{3} \cdot I_{2B}} \cdot \frac{n_s - n_B}{n_s}$$

where n_s = synchronous speed
 n_B = rated speed

The starting or additional rotor resistors are generally disconnected in steps (manually or with contactor control). The number of steps and the individual switching points should be selected such that only low current and torque peaks result. To this end, a multitude of procedures for both symmetrical and asymmetrical starting circuits are described in the technical literature.

Counter-current braking

This form of braking can be used for both squirrel-cage and slip-ring motors. It is realised relatively simply by swapping two of the three three-phase connections. While the centrifugal masses of the drive continue to act in the original direction, the torque already becomes effective in the opposite direction. When the speed reaches zero, the motor must be switched off electrically to avoid a renewed ramp-up in the opposite direction (e.g. by way of a speed monitor). The braking characteristics are dependent on the rotor design.

- For slip-ring motors

the braking characteristics are influenced by the incorporation of additional resistors. Starting and control resistors can be used. The braking effect is greatest where the resistances are changed during braking.

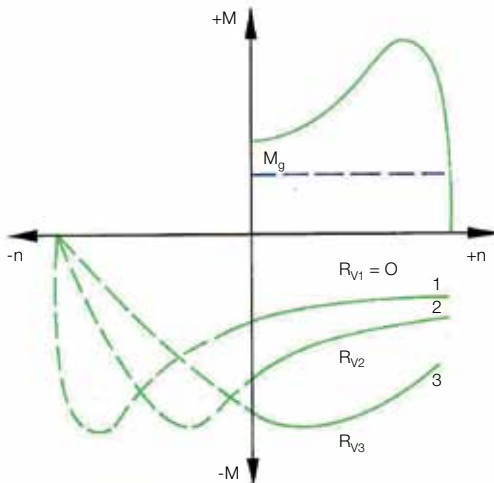

Figure 32: Counter-current braking characteristics

Regarding the thermal loads placed on the motor, it must be noted that the additional warming is around 2 to 3 times that occurring during starting, particularly for squirrel-cage motors, whereas slip-ring motors produce most of the heat externally in the additional resistor. If braking occurs in conjunction with duty type S5, observe the notes given in section 8.3. The duration of occasional counter-current braking should not exceed 10 secs.

DC braking

For this type of braking, the stator of the motor is disconnected from the three-phase mains and subsequently supplied with a direct current after a short interval. The corresponding switching possibilities are shown in Fig. 33. The braking action can be modified by varying the value of the current. The recommended value for the DC braking current is 2 to 2.5 times the motor rated current.

The necessary excitation voltage is calculated with

$$U_G = I_G \cdot R_{ges} \cdot 1.3$$

where I_G = excitation current (DC)
 R_{ges} = total resistance, depending on the braking circuit
 R_{Ph} = phase resistance

The braking characteristic can be derived point by point from the motor characteristics $M = f(n)$ and $I_1 = f(n)$.

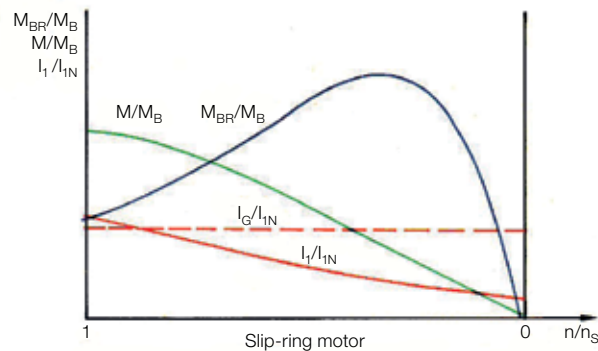

Figure 33: Counter-current braking characteristics for a slip-ring motor

The braking torque is calculated with:

$$M_{Br} = M \left(\frac{K \cdot I_G}{I_1} \right)^2$$

where M = motor torque
 K = braking circuit factor
 I_1 = motor current

Through the incorporation of additional resistors into the rotor circuit of a slip-ring motor, it is possible to achieve greater mean braking torques than with a squirrel-cage motor.

The braking action is gentler than in counter-current braking, there are no shocks acting on the gear unit and/or coupling, and there is no subsequent starting in the opposite direction. Additional mechanical braking may be required towards the end of the braking process. Whether braking is better with DC or counter-current braking can only be decided for an individual case. It is without doubt, however, that DC braking offers a thermal advantage, because the resulting losses are approximately the same as for starting. In case of DC braking in duty type S5, the notes given in section 8.3 must be observed for design.

13.3. Speed control

Control with additional resistors in the rotor circuit

Speed-controlled slip-ring motors can be supplied for the preferred setting ranges 25 %, 50 % and 75 % and for the reaction torque characteristics $M_g = \text{constant}$, $M_g = \text{linear decrease}$ and $M_g = \text{quadratic decrease}$. Due to the poorer efficiency and reduced ventilation, it is not always possible

to achieve the list outputs in operation at speeds below rated speed. The necessary reduction of the standard output, as dependent on the aforementioned parameters, can be taken from the following table.

Speed reduction in %	Output reduction in % of standard output for a given reaction torque characteristic (relative to operation without speed control)		
	constant	linear decrease	quadratic decrease
25	10	0	0
50	20–25	10	0
75	45–50	25–30	0

Speed control with an output reduction of up to 10 % can be realised with slip-ring motors in the basic version. Motors which require an output reduction of more than 10 % are supplied in special design and must be ordered accordingly.

The additional rotor resistors required for the setting range can be determined as follows, taking into account Fig. 34:

$$R_v = \left(\frac{s_r}{s} - 1 \right) \cdot R_2$$

where s_r = slip for the setting range
 s = slip for operation without control

for motors in standard design with standard output

$$s = s_B = \frac{n_s - n_B}{n_s}$$

for motors in standard design with reduced output

$$s = s_B = \frac{M}{M_B}$$

In most cases, it is sufficiently accurate to set $s = s_B$.

for motors in special design with reduced output

$$s = s_{Bh} = \frac{n_s - n_{Bh}}{n_s}$$

where s_B = rated slip
 n_s = synchronous speed
 n_B = rated speed (from technical data)
 M = torque
 M_B = rated torque
 s_{Bh} = rated slip at reduced output with special design
 n_{Bh} = rated speed at reduced output (see rating plate or request from the manufacturer)
 R_2 = equivalent resistance of the rotor winding (for standard version, see technical data; for special designs, consult the manufacturer)
 $R_{2 \text{ warm}} \approx 1.3 \cdot R_2$

As an example, Fig. 35 shows the characteristics of a 6-pole slip-ring motor at 25 % speed setting with linearly decreasing torque.

A modern special version of speed control by way of additional resistors is electronic power control with a pulsed rotor resistor. The circuit for such control is shown in Fig. 36. The change in motor speed is here realised by way of periodic short-circuiting of the additional resistor, which can be equated to continuous modification of the size of this resistor.

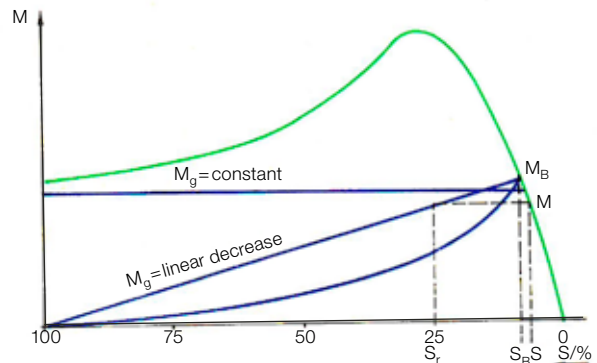

Figure 34: Torque characteristics for a slip-ring motor with speed control

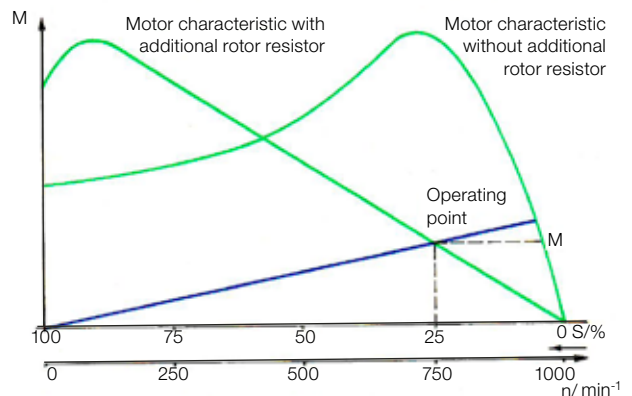

Figure 35: Example of a motor characteristic for speed control by way of an additional resistor

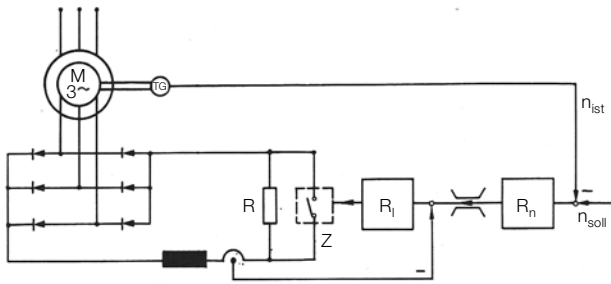

Figure 36: Motor speed control by way of a pulsed rotor resistor

With appropriate control (speed control with secondary two-step current control), it is possible to set any operating point between the limits for permanently short-circuited and permanently active additional resistor. This relatively high outlay, however, is only justified where a demanding technology requires high speed constancy.

Control by way of additional rotor voltages

The speed of a slip-ring motor can be varied freely in either direction to account for varying load by supplying a

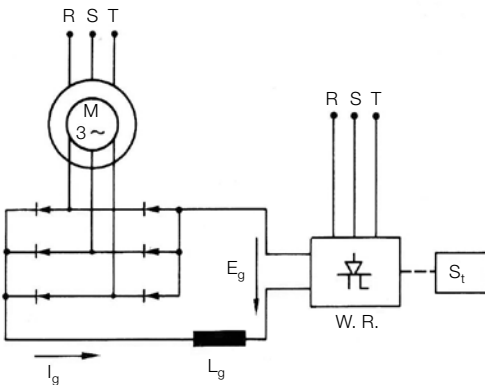

Figure 37: Connection diagram of a subsynchronous converter cascade

13.4. Operation of slip-ring motors with low loads

If a slip-ring motor is operated over a longer period with a load of less than 70 % of the rated output, there is a likelihood of increased brush wear. For this reason, slip-ring motors must be designed such they will not be operated at less than 70 % of the rated output for extended periods.

voltage with slip frequency externally to the slip-ring, either in phase with or in phase opposition to the rotor voltage. This principle is well known for electric machines and is realised in practice, for example, in a three-phase shunt wound motor, where the necessary additional rotor voltage is produced internally by way of a commutator.

If the speed control is limited to the subsynchronous range, significant simplification is possible. It is sufficient to withdraw energy from the rotor. The frequency-dependent rotor voltage can be supplied via a power electronics module with DC link. This module serves to return rotor energy to the grid via a line-commutated inverter. The connection diagram of such an arrangement can be seen in Fig. 37.

The basic load characteristics of the aforementioned subsynchronous converter cascade are shown in Fig. 38. The speed-torque behaviour is characterised by parallel shifting of the curves, where only the straight sections are generally relevant for practical operation.

When designing a drive with speed control, it is almost always necessary to consult the manufacturer, where possible with precise specification of all data which are decisive for the application.

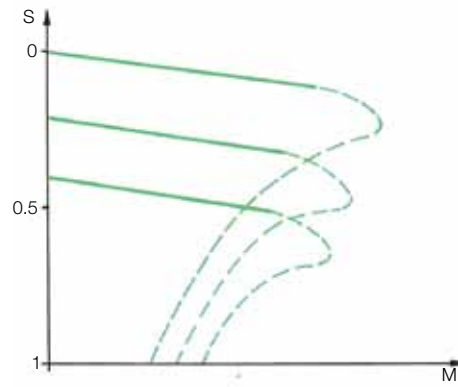

Figure 38: Load characteristic of a subsynchronous converter cascade

In exceptional cases, special agreements must be reached with the manufacturer. The work cycle and operating conditions must be specified, and appropriate testing may be necessary.

13.5. Selsyn arrangements

In certain applications where plant is spread over a wide area, as well as for slide rest drives on lathes or loading gantries, for example, it is necessary to maintain synchronicity between separate section drives. A mechanical shaft connection is often not feasible due to the physical circumstances. The solution is to simulate a shaft by electric means with a so-called selsyn.

A selsyn is set up by connecting like phases on the stator and rotor sides of two or more slip-ring motors. Depending on the requirements with regard to power transmission, angular positioning, etc., there are two commonly used arrangements, namely the power selsyn (Fig. 39) and the differential selsyn (Fig. 40).

Correct planning of an electric synchronisation arrangement requires precise knowledge of the overall system, and in particular of those elements of the drive which interact with the selsyn. This overall view is imperative for proper judgement of the dynamic stability.

The selsyn represents an elastic link between the machine groups, the rotating masses of which are in this way coupled as if by torsion springs and can thus display torsional vibration.

It is imperative to check the dynamic behaviour, as proper functioning of the synchronisation arrangement is no longer guaranteed in case of resonances or inadequate damping of the mutual vibration in the drive groups.

Selsyns can be realised through any of a variety of connection possibilities with different static and dynamic properties; details of the different arrangements can be found in the relevant technical literature.

Dynamic susceptibility is not necessarily attributable to the selsyn; it may also result from resonance phenomena in the overall system. Through suitable design measures, e.g. the targeted placement of balancing masses, it may be possible to rectify such susceptibility. To enable the selection of suitable selsyn machines from the available range of slip-ring motor types, the following information must be provided with the order:

- Description of the overall system in terms of type, design, function principle and operating conditions, where related in any way to the selsyn
- Description of the work cycle, specifying the maximum short-time or continuous torques to be transmitted by the selsyn, together with the corresponding speeds and any existing irregularities in the torque
- Information on the type of the main drive motor, especially with regard to ramp-up properties and the response speed for motor speed control
- Maximum permissible rotation angle between the transmitter and the receiver
- Specification of the type of synchronisation (at standstill or running)
- Rotating masses coupled with the selsyn machines in the different operating states.

The following points should be taken into account for preselection of the most suitable variant:

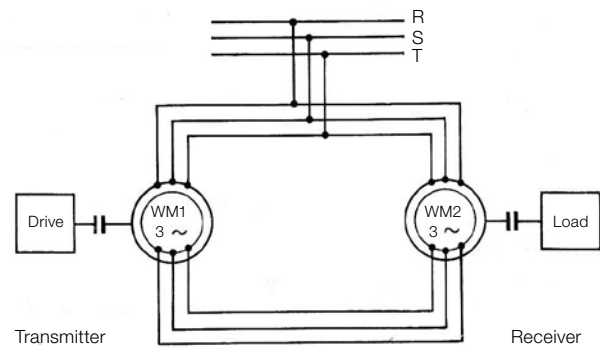

Figure 39: Power selsyn

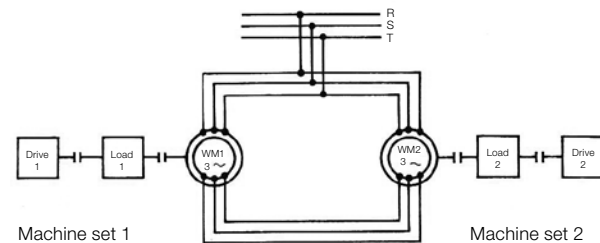

Figure 40: Differential selsyn

For differential selsyns, rotation in opposition to the rotating field is to be preferred, as this enables the best possible type utilisation. The prerequisite, however, is that the dynamic stability of the system remains guaranteed. For this reason, it may be necessary to prefer operation with the rotating field under certain circumstances, if the external damping is only very low and there is no alternative to the use of damping resistors for stabilisation. For power selsyns, rotation in the sense of the rotating field is to be preferred. It is only in special cases, e.g. very high speeds up to and above the synchronous speed or reversing operation where reversal of the rotating field is not possible at standstill, that a power selsyn may also be operated with rotation in opposition to the rotating field.

When the selsyn is operated in opposition to the rotating field, the rotor frequency and rotor voltage reach values which do not otherwise occur in normal operation. The iron losses in the rotor are thus higher than usual. In such cases, particular attention must be paid to the thermal behaviour of the selsyn machines. Normal slip-ring motors possess self-ventilation, the intensity of which is naturally reduced at lower speeds. The losses which can be dissipated at slow speeds are thus significantly lower than in normal operation. For this reason, considerable limitation of the permissible load is often inevitable. When planning a synchronisation arrangement of any kind, therefore, it is always advisable to consult the manufacturer. In many cases, testing will be imperative.

No claims are raised as to the completeness of the information on motor configuration and corresponding applications provided in this chapter. This information is intended merely to help the user to understand drive problems and to confidently preselect a suitable three-phase electric motor for the given drive application. All information has been gathered and checked with the utmost care. Nevertheless, we are unable to accept liability of any kind regarding possible errors, omissions or inconsistencies.

Wherever our customers need electric machines, we are at hand as a partner and offer every necessary support at all phases of a project. It is not important whether you are doing business in Europe, the Middle East, Asia or America. As the VEM market share increases also outside Germany, we are expanding our sales network with a combination of own subsidiary companies and strategic alliances. Already today, our customers can address their questions to competent and experienced local partners all over the world. Alongside VEM subsidiaries in Finland, Great Britain, Norway, Austria and Singapore, we have established a dense network of sales and service contacts with agents and representatives in more than 40 countries.

VEM-Product Range

Low-voltage machines

Three-phase asynchronous motors with squirrel-cage rotor
up to 710 kW as energy saving motors in efficiency classes
IE3, IE2, IE1 according to IEC/EN 60034-30-1/IEC 60034-2-1
Three-phase asynchronous motors with slip ring rotor up to 315 kW
Roller table motors up to 710 kW
Explosion-protected motors up to 630 kW
Crane motors and marine motors
Special motors with brake, forced ventilator, encoder
Compact drives up to 22 kW
Built-in motors
Three-phase asynchronous generators

High-voltage machines

High-voltage asynchronous motors up to 28 MW
High-voltage synchronous motors up to 42 MW
High-voltage synchronous generators to 45 MVA
Traction machines
Wind power generators up to 7 MW

Foundry products

Custom-made castings
Fittings, Valves, Hydrants
Architectural casting

Further information about our delivery program and our product range
you can find in the Internet under www.vem-group.com

You can also request a copy of our electronic catalogue
on a USB stick.

Technical modification

We strive to improve our products whenever and wherever possible. Consequently, technical data
and illustrations remain subject to change. Specifications may only be considered binding following
written confirmation by the supplier

Liability, duty to obtain a permit

All information are without any engagement. For printing errors we don't take over any liability.

Copies, reprints, saving files or publication are only possible with specific acceptance of
VEM motors GmbH.

The products featured in this catalogue are also contained in our interactive VEM catalogue.

Further information on the companies and products of the VEM Group can be found at
www.vem.group.com.

The electronic catalogue VEMeKAT assists you in the selection and configuration of VEM products.
You are able to print out both data sheets and product enquiries, while dimensioned and scale
drawings can be displayed or exported in various 2D and 3D formats. In addition to general
information about the VEM Group, you have direct access via the program to catalogues, spare
parts lists, operating and maintenance instructions, test certificates and circuit diagrams of the
individual products.

VEM Holding GmbH

Pirnaer Landstraße 176
01257 Dresden
Germany

Sales

Low voltage department

Tel. +49 3943 68-3127
Fax +49 3943 68-2440
E-Mail: low-voltage@vem-group.com

High voltage department

Tel. +49 351 208-3237
Fax +49 351 208-1108
E-Mail: high-voltage@vem-group.com

Drive systems department

Tel. +49 351 208-1180
Fax +49 351 208-1185
E-Mail: drive-systems@vem-group.com

VEM Service

Tel. +49 351 208-3237
Fax +49 351 208-1108
E-Mail: service@vem-group.com



For detailed information
please visit our website.

www.vem-group.com