

2.0	RIDUTTORE A VITE SENZA FINE X	X WORM GEARBOXES	SCHNECKENGETRIEBE X	
2.1	Caratteristiche	<i>Characteristics</i>	Merkmale	14
2.2	Designazione	<i>Designation</i>	Bezeichnung	15
2.3	Lubrificazione e posizioni di montaggio	<i>Lubrication and mounting position</i>	Schmierung und Einbaulage	16
2.4	Posizione morsettiere	<i>Terminal board positions</i>	Lage der Klemmenkaste	16
2.5	Dati tecnici	<i>Technical data</i>	Technische Daten	17
2.6	Momenti d'inerzia	<i>Moment of inertia</i>	Trägheitsmoment	24
2.7	Dimensioni	<i>Dimensions</i>	Abmessungen	26
2.8	Entrata supplementare	<i>Additional input</i>	Zusatzantrieb	31
2.9	Limitatore di coppia cavo passante	<i>Torque limiter with through hollow shaft</i>	Drehmomentbegrenzer mit durchgehender Hohlwelle	31
2.10	Accessori	<i>Accessories</i>	Zubehör	33
2.11	Lista parti di ricambio	<i>Spare parts list</i>	Ersatzteilliste	34

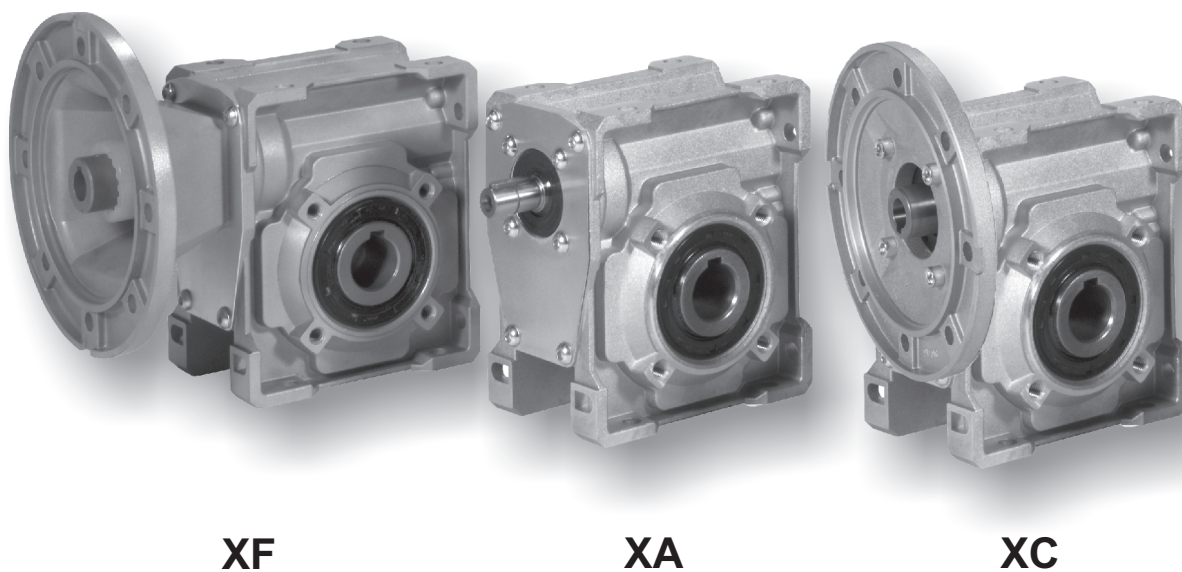

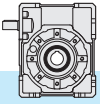

2.1 Caratteristiche

- I riduttori a vite senza fine della serie X sono disponibili nelle versioni alberata XA e con predisposizione per attacco motore XF-XC.
- La versione XF (campana + giunto), caratterizzata da una più ampia versatilità ai diversi tipi di applicazioni, presenta un più elevato rendimento rispetto a quello della serie compatta XC la quale, a sua volta, presenta il vantaggio di un ingombro più ridotto.
- La carcassa monoblocco è in ghisa nelle grandezze 90 e 110 e in alluminio pressofuso per le grandezze inferiori.
- La vite senza fine è in acciaio legato cementato-temprato ed è rettificata.
- La corona ha il mozzo in ghisa con riporto di fusione dell'anello in bronzo.
- Le carcasse in ghisa sono verniciate BLU RAL5010 mentre quelle in alluminio sono sabbiate.
- Viene fornito l'albero uscita cavo di serie ed esiste un'ampia disponibilità di accessori: seconda entrata, cuscinetti conici sulla corona, flangia uscita, albero lento con 1 o 2 sporgenze, limitatore di coppia con cavo passante, braccio di reazione, kit protezione albero cavo, kit protezione limitatore di coppia.

2.1 Characteristics

- *X series worm gearboxes are available in the following versions : XA with shaft, XF and XC suitable for motor mounting assembling.*
- *The XF version (bell + joint) suits a wider range of applications and provides higher efficiency than the XC compact version, which actually offers reduced space requirement.*
- *The enbloc housing is in cast-iron for sizes 90 and 110, in die-cast aluminium for smaller sizes.*
- *The worm shaft is in case-and quenched alloy steel and ground.*
- *The worm wheel has a cast-iron hub provided with inserted cast-bronze ring.*
- *The housings in cast iron are painted BLUE RAL 5010, those in aluminium are sandblasted.*
- *The hollow output shaft is supplied as standard. A broad range of accessories is available: second input, tapered roller bearings on the worm wheel, output flange, single or double-extended output shaft, torque limiter with through hollow shaft, torque arm, hollow shaft protection kit, torque limiter protection kit.*

2.1 Merkmale

- Die Schneckengetriebe der Serie X sind in den Versionen XA mit Welle und XF / XC mit Motoranschluß lieferbar.
- Die Version XF (Glocke + Kupplung), die sich durch ihre zahlreichen Anwendungsmöglichkeiten auszeichnet, bietet höhere Leistung als die Kompaktserie XC, die wiederum Vorteile im Sinne der Platzerparnis mit sich bringt.
- Das Blockgehäuse ist aus Gußeisen für die Baugrößen 90 und 110, aus Aluminiumdruckguß für die kleineren Versionen.
- Die Schnecke ist aus einsatzgehärtetem/abgeschrecktem und daraufhin geschliffenen Legierungsstahl.
- Das Schneckenrad besteht aus einer Nabe aus Gusseisen und einem aufgeschleuderten Gussbronze –Ring.
- Das Schneckenrad aus Gußeisen werden mit BLAU RAL 5010 lackiert, die aus Aluminium werden sandgestrahlt.
- Die Hohlwelle gehört zur serienmäßigen Ausstattung. Zahlreiches Zubehör ist lieferbar: zweiter Antrieb, Kegellager auf das Schneckenrad, Abtriebsflansch, standard oder doppelseitig herausragende Abtriebswelle, Drehmomentbegrenzer mit durchgehender Hohlwelle, Drehmomentstütze, Schutzvorrichtung für Hohlwelle, Schutzvorrichtung für Drehmomentbegrenzer.

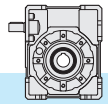

2.2 Designazione

2.2 Designation

2.2 Bezeichnung

Riduttore Gearbox Getriebe	Tipo entrata Input type Antriebsart	Grandezza Size Größe	Rapporto rid. Ratio Untersetzung	Predispos.att. mot. Motor coupling Motoranschluss	Posizione di mont. Mounting position Einbaulage	Flangia in uscita. Output flange Abtriebsflansch	Limitatore di coppia. Torque limiter Drehmomentbegrenzer	Seconda entrata Additional input Zusatzantrieb	Albero uscita Output shaft Abtriebswelle	Braccio di reazione Torque arm Drehmomentstütze
X	A	50	10/1	P.A.M	B3	F1S	LD	SeA	H	BR
Riduttore a avite senza fine Wormgearbox Schneckengetriebe	A C F	30 40 50 63 75 90 110	7.5 10 15 20 25 30 40 50 65 80 100	56 63 71 80 90 100 112 132	B3, B6 B7, B8 V5, V6	F1D-F2D-F3D F1S-F2S-F3S F12-F22-F32	LD LS	SeA	H SD SS DD	BR

Tipo entrata

Input type

Antriebstyp

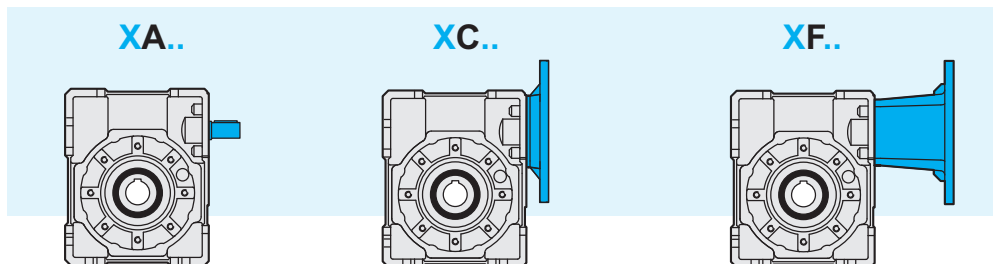

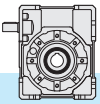

2.3 Lubrificazione

I riduttori a vite senza fine serie X sono forniti completi di lubrificante sintetico a base PAG con indice di viscosità ISO VG320. Si raccomanda di precisare sempre, in fase di ordine, la posizione di lavoro desiderata.

Posizioni di montaggio

2.3 Lubrication

X series worm gearboxes are supplied with synthetic lubricant, PAG base, viscosity index ISO VG320. Always specify the required mounting position when ordering the gearbox.

Mounting positions

2.3 Schmierung

Schneckengetriebe der Serie X werden mit synthetischem Schmiermittel auf PAG Basis und Viskosität Index ISO VG320 geliefert. Im Auftrag bitte immer die gewünschte Einbaulage angeben.

Einbaulagen

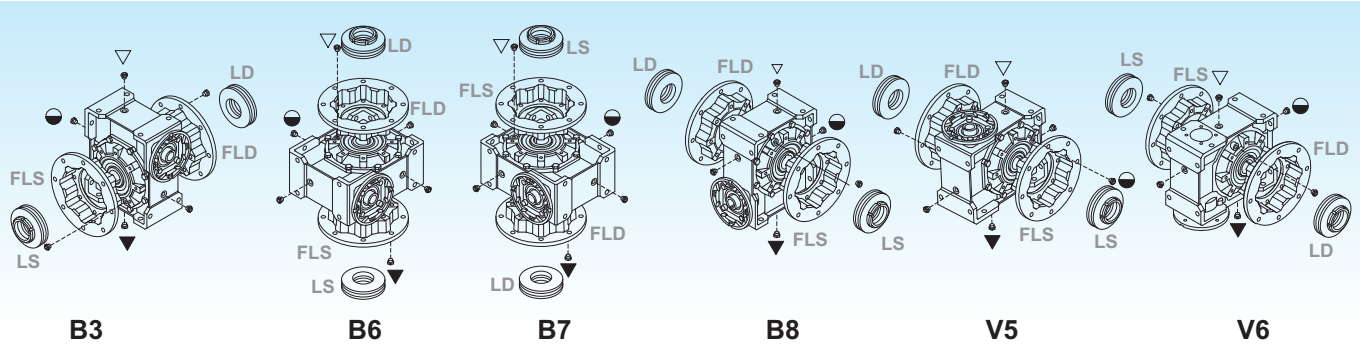

		Q.tà olio / Oil quantity / Schmiermittelmenge [lt]			
		Posizione di montaggio / Mounting position / Einbaulage			
		B3	B6 - B7	B8	V5 - V6
X	30	0.04			
	40	0.07			
	50	0.15			
	63	0.4			
	75	0.6			
	90	1.1	0.90	1.3	1.2
110	2.4	2.0	2.8	2.7	

- ▽ Carico e sfiato / Filling and breather
Einfüll und Entlüftung
- Livello / Level / Ölstand
- ▼ Scarico / Drain / Ablass

Nei corpi in alluminio 30, 40, 50, 63,75 è presente un solo tappo di riempimento olio.

30, 40, 50, 63 and 75 aluminium housings have one oil filling plug only.

30, 40, 50, 63 and 75 Aluminiumgehäuse verfügen über 1 Einfüllschraube.

2.4 Posizione morsettiera

2.4 Terminal board position

2.4 Lage der Klemmenkaste

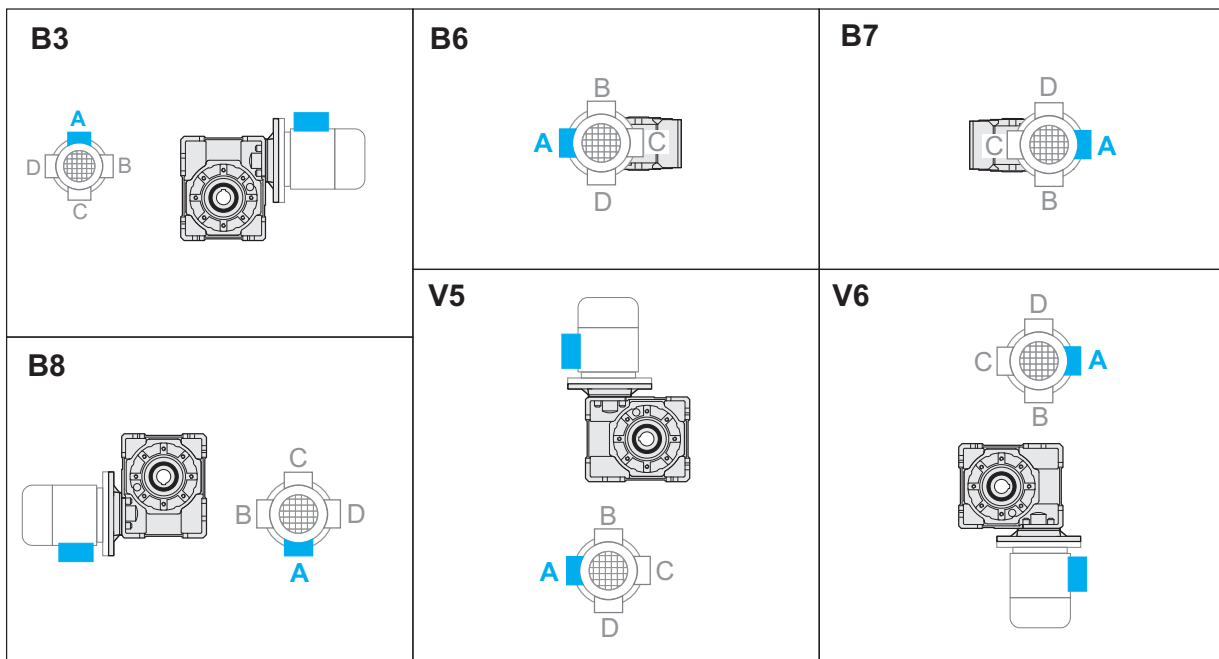

Specificare sempre in fase di ordinazione la posizione di montaggio e la forma costruttiva.

Specify the version and the mounting position when ordering.

Bei der Bestellung immer die gewünschte Montageposition und Bauform angeben.

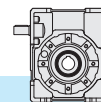

2.5 Dati tecnici

2.5 Technical data

2.5 Technische Daten

30	$n_1 = 2800$		XC - XF						XA						
	i_n	n_2 [min ⁻¹]	T_2 [Nm]	P_1 [kW]	FS'	Input - IEC						T_{2M} [Nm]	P [kW]	Rd	P_{10}
						XC		XF		B14					
						B5/B14	B5	B5	B14						
7.5	373	8	0.37	2.0	63	56	63	56	63	56	16	0.72	0.86	—	
10	280	11	0.37	1.5							16	0.56	0.84		
15	187	15	0.37	1.1							17	0.41	0.81		
20	140	13	0.25	1.2							15	0.29	0.76		
25	112	16	0.25	1.0							16	0.25	0.74		
30	93	13	0.18	1.0							13	0.18	0.71		
40	70	16	0.18	1.0							16	0.18	0.65		
50	56	14	0.13	1.1							15	0.14	0.62		
65	43	17	0.13	1.0							17	0.13	0.57		
80	35	13	0.09	1.0							13	0.09	0.54		
100	28	16	0.09	0.8	—	—	—	—	—	12	0.07	0.52	—		

30	$n_1 = 1400$		XC - XF						XA						
	i_n	n_2 [min ⁻¹]	T_2 [Nm]	P_1 [kW]	FS'	Input - IEC						T_{2M} [Nm]	P [kW]	Rd	P_{10}
						XC		XF		B14					
						B5/B14	B5	B5	B14						
7.5	187	9	0.22	2.2	63	56	63	56	63	56	21	0.49	0.84	0.40	
10	140	12	0.22	1.8							22	0.40	0.82	0.40	
15	93	17	0.22	1.3							22	0.28	0.77	0.30	
20	70	18	0.18	1.1							19	0.19	0.72	0.20	
25	56	21	0.18	1.0							21	0.18	0.69	0.20	
30	47	18	0.13	1.1							20	0.15	0.66	0.20	
40	35	21	0.13	1.0							21	0.13	0.59	0.20	
50	28	17	0.09	1.1							19	0.10	0.55	0.20	
65	22	20	0.09	1.0							20	0.09	0.51	0.10	
80	18	16	0.06	1.0							17	0.06	0.48	0.10	
100	14	18	0.06	0.8	—	—	—	—	—	14	0.05	0.45	0.10		

30	$n_1 = 900$		XC - XF						XA						
	i_n	n_2 [min ⁻¹]	T_2 [Nm]	P_1 [kW]	FS'	Input - IEC						T_{2M} [Nm]	P [kW]	Rd	P_{10}
						XC		XF		B14					
						B5/B14	B5	B5	B14						
7.5	120	9	0.13	2.9	63	56	63	56	63	56	25	0.38	0.82	—	
10	90	11	0.13	2.3							25	0.30	0.80		
15	60	15	0.13	1.6							25	0.21	0.75		
20	45	19	0.13	1.2							22	0.15	0.69		
25	36	23	0.13	1.1							24	0.14	0.66		
30	30	18	0.09	1.2							21	0.10	0.63		
40	23	21	0.09	1.1							24	0.10	0.55		
50	18	16	0.06	1.1							21	0.08	0.52		
65	14	20	0.06	1.1							22	0.07	0.48		
80	11	11	0.03	1.7							19	0.05	0.44		
100	9	13	0.03	1.1	—	—	—	—	—	15	0.03	0.42	—		

30	$n_1 = 500$		XC - XF						XA						
	i_n	n_2 [min ⁻¹]	T_2 [Nm]	P_1 [kW]	FS'	Input - IEC						T_{2M} [Nm]	P [kW]	Rd	P_{10}
						XC		XF		B14					
						B5/B14	B5	B5	B14						
7.5	67	—	—	—	63	56	63	56	63	56	31	0.27	0.80	—	
10	50	—	—	—							31	0.21	0.77		
15	33	—	—	—							31	0.15	0.72		
20	25	—	—	—							26	0.10	0.66		
25	20	—	—	—							27	0.09	0.62		
30	17	—	—	—							25	0.07	0.59		
40	13	—	—	—							28	0.07	0.51		
50	10	—	—	—							25	0.06	0.48		
65	8	—	—	—							25	0.05	0.43		
80	6	—	—	—							20	0.03	0.40		
100	5	—	—	—	—	—	—	—	—	16	0.02	0.38	—		

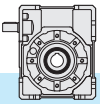

2.5 Dati tecnici

2.5 Technical data

2.5 Technische Daten

40	n₁ = 2800		XC - XF									XA						
	i _n	n ₂ [min ⁻¹]	T ₂ [Nm]	P ₁ [kW]	FS'	Input - IEC									T _{2M} [Nm]	P [kW]	Rd	P _{t0}
						XC			XF			B14						
						B5/B14			B5			B14						
7.5	373	17	0.75	1.8	71	63	—	71	63	56	71	63	—	30	1.3	0.87	—	
10	280	22	0.75	1.4										31	1.1	0.86		
15	187	32	0.75	1.0										32	0.76	0.82		
20	140	30	0.55	1.0										31	0.57	0.80		
25	112	24	0.37	1.1										27	0.41	0.76		
30	93	28	0.37	1.3										35	0.47	0.73		
40	70	24	0.25	1.4	33	0.35	0.70											
50	56	28	0.25	1.1	30	0.27	0.65											
65	43	24	0.18	1.2	28	0.21	0.61											
80	35	21	0.13	1.3	26	0.16	0.58											
100	28	24	0.13	1.0	25	0.13	0.55											

40	n₁ = 1400		XC - XF									XA						
	i _n	n ₂ [min ⁻¹]	T ₂ [Nm]	P ₁ [kW]	FS'	Input - IEC									T _{2M} [Nm]	P [kW]	Rd	P _{t0}
						XC			XF			B14						
						B5/B14			B5			B14						
7.5	187	24	0.55	1.7	71	63	—	71	63	56	71	63	—	40	0.92	0.85	0.80	
10	140	31	0.55	1.3										41	0.73	0.83	0.70	
15	93	30	0.37	1.4										42	0.52	0.79	0.50	
20	70	38	0.37	1.0										40	0.39	0.76	0.50	
25	56	31	0.25	1.1										35	0.29	0.72	0.40	
30	47	35	0.25	1.2										41	0.29	0.68	0.40	
40	35	38	0.22	1.0	38	0.22	0.64	0.30										
50	28	36	0.18	1.1	38	0.19	0.59	0.30										
65	22	31	0.13	1.1	35	0.15	0.54	0.20										
80	18	31	0.11	1.1	33	0.12	0.52	0.20										
100	14	30	0.09	0.9	28	0.08	0.49	0.20										

40	n₁ = 900		XC - XF									XA						
	i _n	n ₂ [min ⁻¹]	T ₂ [Nm]	P ₁ [kW]	FS'	Input - IEC									T _{2M} [Nm]	P [kW]	Rd	P _{t0}
						XC			XF			B14						
						B5/B14			B5			B14						
7.5	120	25	0.37	2.0	71	63	—	71	63	56	71	63	—	48	0.72	0.83	—	
10	90	32	0.37	1.5										48	0.56	0.81		
15	60	45	0.37	1.1										49	0.40	0.76		
20	45	39	0.25	1.2										46	0.29	0.74		
25	36	33	0.18	1.3										42	0.23	0.69		
30	30	37	0.18	1.3										48	0.23	0.65		
40	23	33	0.13	1.3	42	0.16	0.61											
50	18	38	0.13	1.1	42	0.14	0.55											
65	14	32	0.09	1.2	39	0.11	0.51											
80	11	37	0.09	1.0	37	0.09	0.48											
100	9	29	0.06	1.0	30	0.06	0.45											

40	n₁ = 500		XC - XF									XA						
	i _n	n ₂ [min ⁻¹]	T ₂ [Nm]	P ₁ [kW]	FS'	Input - IEC									T _{2M} [Nm]	P [kW]	Rd	P _{t0}
						XC			XF			B14						
						B5/B14			B5			B14						
7.5	67	10	0.09	5.5	71	63	—	71	63	56	71	63	—	58	0.50	0.81	—	
10	50	14	0.09	4.4										59	0.39	0.79		
15	33	19	0.09	3.1										59	0.28	0.73		
20	25	24	0.09	2.3										55	0.20	0.70		
25	20	28	0.09	1.7										48	0.15	0.65		
30	17	31	0.09	1.8										58	0.17	0.61		
40	13	39	0.09	1.3	52	0.12	0.57											
50	10	44	0.09	1.2	51	0.11	0.51											
65	8	52	0.09	0.9	45	0.08	0.46											
80	6	61*	0.09	0.7*	42	0.06	0.44											
100	5	71*	0.09	0.4*	32	0.04	0.41											

* **ATTENZIONE:** la coppia massima utilizzabile [T_{2M}] deve essere calcolata utilizzando il fattore di servizio: T_{2M} = T₂ x FS'

* **WARNING:** Maximum allowable torque [T_{2M}] must be calculated using the following service factor: T_{2M} = T₂ x FS'

* **ACHTUNG:** das max. anwendbare Drehmoment [T_{2M}] muss mit folgendem Betriebsfaktor berechnet werden: T_{2M} = T₂ x FS'

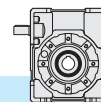

2.5 Dati tecnici

2.5 Technical data

2.5 Technische Daten

50	n₁ = 2800					XC - XF						XA					
	i _n	n ₂ [min ⁻¹]	T ₂ [Nm]	P ₁ [kW]	FS'	Input - IEC						T _{2M} [Nm]	P [kW]	Rd	P _{t0}		
						XC		XF		B14	B14					B14	B14
						B5/B14	B5	B5	B14								
7.5	373	34	1.5	1.5	80	71	—	80	71	63	80	71	—	51	2.3	0.88	—
10	280	44	1.5	1.2										54	1.8	0.86	
15	187	47	1.1	1.2										57	1.3	0.84	
20	140	42	0.75	1.4										58	1.0	0.81	
25	112	50	0.75	1.0										50	0.75	0.78	
30	93	42	0.55	1.3										55	0.71	0.75	
40	70	54	0.55	1.0	—	63	—	63	—	—	—	—	54	0.63	0.72		
50	56	43	0.37	1.3									56	0.48	0.68		
65	43	53	0.37	1.0									53	0.37	0.64		
80	35	41	0.25	1.2									48	0.29	0.61		
100	28	35	0.18	1.3									45	0.23	0.58		

50	n₁ = 1400					XC - XF						XA					
	i _n	n ₂ [min ⁻¹]	T ₂ [Nm]	P ₁ [kW]	FS'	Input - IEC						T _{2M} [Nm]	P [kW]	Rd	P _{t0}		
						XC		XF		B14	B14					B14	B14
						B5/B14	B5	B5	B14								
7.5	187	40	0.9	1.8	80	71	—	80	71	63	80	71	—	70	1.6	0.86	1.2
10	140	52	0.9	1.4										73	1.3	0.84	1.0
15	93	74	0.9	1.0										74	0.90	0.80	0.80
20	70	58	0.55	1.3										75	0.71	0.78	0.70
25	56	47	0.37	1.4										65	0.51	0.74	0.60
30	47	53	0.37	1.2										66	0.46	0.71	0.60
40	35	68	0.37	1.0	—	63	—	63	—	—	—	—	69	0.38	0.67	0.50	
50	28	53	0.25	1.3									70	0.33	0.62	0.40	
65	22	64	0.25	1.0									64	0.25	0.58	0.40	
80	18	53	0.18	1.1									60	0.20	0.54	0.40	
100	14	45	0.13	1.2									55	0.16	0.51	0.30	

50	n₁ = 900					XC - XF						XA					
	i _n	n ₂ [min ⁻¹]	T ₂ [Nm]	P ₁ [kW]	FS'	Input - IEC						T _{2M} [Nm]	P [kW]	Rd	P _{t0}		
						XC		XF		B14	B14					B14	B14
						B5/B14	B5	B5	B14								
7.5	120	50	0.75	1.6	80	71	—	80	71	63	80	71	—	83	1.23	0.84	—
10	90	66	0.75	1.3										86	0.98	0.82	
15	60	68	0.55	1.3										88	0.71	0.78	
20	45	59	0.37	1.5										87	0.54	0.75	
25	36	70	0.37	1.1										75	0.40	0.71	
30	30	79	0.37	1.0										79	0.37	0.67	
40	23	67	0.25	1.1	—	63	—	63	—	—	—	—	75	0.28	0.63		
50	18	78	0.25	1.0									80	0.26	0.59		
65	14	67	0.18	1.1									74	0.20	0.54		
80	11	56	0.13	1.2									67	0.16	0.51		
100	9	45	0.09	1.3									58	0.12	0.47		

50	n₁ = 500					XC - XF						XA					
	i _n	n ₂ [min ⁻¹]	T ₂ [Nm]	P ₁ [kW]	FS'	Input - IEC						T _{2M} [Nm]	P [kW]	Rd	P _{t0}		
						XC		XF		B14	B14					B14	B14
						B5/B14	B5	B5	B14								
7.5	67	21	0.18	4.7	80	71	—	80	71	63	80	71	—	100	0.85	0.82	—
10	50	28	0.18	3.8										104	0.68	0.80	
15	33	39	0.18	2.7										106	0.49	0.75	
20	25	50	0.18	2.1										104	0.38	0.72	
25	20	58	0.18	1.5										88	0.27	0.68	
30	17	65	0.18	1.5										98	0.27	0.63	
40	13	81	0.18	1.2	—	63	—	63	—	—	—	—	95	0.21	0.59		
50	10	93	0.18	1.0									94	0.18	0.54		
65	8	56	0.09	1.5									86	0.14	0.50		
80	6	63	0.09	1.2									77	0.11	0.46		
100	5	74	0.09	0.8									61	0.07	0.43		

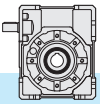

2.5 Dati tecnici

2.5 Technical data

2.5 Technische Daten

63	$n_1 = 2800$		XC - XF								XA						
	i_n	n_2 [min ⁻¹]	T_2 [Nm]	P_1 [kW]	FS'	Input - IEC						T_{2M} [Nm]	P [kW]	Rd	P_{t0}		
						XC		XF		B14							
						B5/B14		B5		B14							
7.5	373	68	3	1.3	90	80	—	90	80	71	90	80	—	88	3.9	0.88	—
10	280	89	3	1.1										94	3.2	0.87	
15	187	95	2.2	1.0	—	71	—	—	—	—	—	—	98	2.3	0.84	—	
20	140	85	1.5	1.3									110	1.9	0.83		
25	112	76	1.1	1.2	—	—	—	—	—	—	—	—	93	1.4	0.81	—	
30	93	87	1.1	1.3									110	1.4	0.77		
40	70	111	1.1	1.1	—	—	—	—	—	—	—	—	117	1.2	0.74	—	
50	56	90	0.75	1.1									97	0.81	0.70		
65	43	81	0.55	1.2	—	—	—	—	—	—	—	—	98	0.66	0.67	—	
80	35	65	0.37	1.4									91	0.52	0.64		
100	28	75	0.37	1.1	—	—	—	—	—	—	—	—	83	0.41	0.60	—	
6.6	6.6	6.6	6.6	6.6									6.6	6.6	6.6		6.6

63	$n_1 = 1400$		XC - XF								XA						
	i_n	n_2 [min ⁻¹]	T_2 [Nm]	P_1 [kW]	FS'	Input - IEC						T_{2M} [Nm]	P [kW]	Rd	P_{t0}		
						XC		XF		B14							
						B5/B14		B5		B14							
7.5	187	80	1.8	1.5	90	80	—	90	80	71	90	80	—	120	2.7	0.87	1.8
10	140	105	1.8	1.2										127	2.2	0.85	1.6
15	93	125	1.5	1.1	—	71	—	—	—	—	—	—	130	1.6	0.81	1.2	
20	70	120	1.1	1.2									144	1.3	0.80	1.2	
25	56	118	0.9	1.0	—	—	—	—	—	—	—	—	118	0.90	0.77	1.0	
30	47	134	0.9	1.1									142	0.95	0.73	0.90	
40	35	142	0.75	1.1	—	—	—	—	—	—	—	—	150	0.79	0.69	0.80	
50	28	122	0.55	1.0									122	0.55	0.65	0.70	
65	22	100	0.37	1.2	—	—	—	—	—	—	—	—	122	0.45	0.61	0.60	
80	18	79	0.25	1.4									113	0.36	0.58	0.60	
100	14	91	0.25	1.1	—	—	—	—	—	—	—	—	102	0.28	0.53	0.50	

63	$n_1 = 900$		XC - XF								XA						
	i_n	n_2 [min ⁻¹]	T_2 [Nm]	P_1 [kW]	FS'	Input - IEC						T_{2M} [Nm]	P [kW]	Rd	P_{t0}		
						XC		XF		B14							
						B5/B14		B5		B14							
7.5	120	102	1.5	1.4	90	80	—	90	80	71	90	80	—	144	2.1	0.85	—
10	90	133	1.5	1.1										150	1.7	0.83	
15	60	139	1.1	1.1	—	71	—	—	—	—	—	—	152	1.2	0.79	—	
20	45	123	0.75	1.4									167	1.0	0.77		
25	36	109	0.55	1.3	—	—	—	—	—	—	—	—	140	0.71	0.74	—	
30	30	122	0.55	1.3									164	0.74	0.70		
40	23	154	0.55	1.1	—	—	—	—	—	—	—	—	171	0.61	0.66	—	
50	18	120	0.37	1.2									141	0.44	0.61		
65	14	98	0.25	1.4	—	—	—	—	—	—	—	—	139	0.35	0.57	—	
80	11	115	0.25	1.1									128	0.28	0.54		
100	9	95	0.18	1.2	—	—	—	—	—	—	—	—	115	0.22	0.50	—	

63	$n_1 = 500$		XC - XF								XA						
	i_n	n_2 [min ⁻¹]	T_2 [Nm]	P_1 [kW]	FS'	Input - IEC						T_{2M} [Nm]	P [kW]	Rd	P_{t0}		
						XC		XF		B14							
						B5/B14		B5		B14							
7.5	67	30	0.25	5.9	90	80	—	90	80	71	90	80	—	177	1.5	0.83	—
10	50	39	0.25	4.7										182	1.2	0.81	
15	33	55	0.25	3.4	—	71	—	—	—	—	—	—	184	0.84	0.76	—	
20	25	71	0.25	2.8									200	0.70	0.74		
25	20	85	0.25	1.9	—	—	—	—	—	—	—	—	165	0.49	0.71	—	
30	17	94	0.25	2.1									195	0.52	0.65		
40	13	118	0.25	1.7	—	—	—	—	—	—	—	—	201	0.43	0.62	—	
50	10	135	0.25	1.2									165	0.31	0.56		
65	8	163	0.25	1.0	—	—	—	—	—	—	—	—	161	0.25	0.52	—	
80	6	137	0.18	1.1									148	0.19	0.50		
100	5	77	0.09	1.6	—	—	—	—	—	—	—	—	122	0.14	0.45	—	

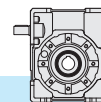

2.5 Dati tecnici

2.5 Technical data

2.5 Technische Daten

75	$n_1 = 2800$		XC - XF										XA						
	i_n	n_2 [min ⁻¹]	T_2 [Nm]	P_1 [kW]	FS'	Input - IEC										T_{2M} [Nm]	P [kW]	Rd	P_{t0}
						XC			XF				B14						
						B5/B14			B5				B14						
7.5	373	125	5.5	1.0	112 100	90	—	112 100	90	80	112 100	90	—	131	5.8	0.89	—		
10	280	120	4	1.2										143	4.8	0.88			
15	187	131	3	1.2	152	3.5	0.85												
20	140	171	3	1.0	172	3.0	0.84												
25	112	154	2.2	1.0	155	2.2	0.82												
30	93	120	1.5	1.4	170	2.1	0.78												
40	70	154	1.5	1.2	183	1.8	0.75												
50	56	136	1.1	1.2	166	1.3	0.73												
65	43	114	0.75	1.4	155	1.0	0.69												
80	35	135	0.75	1.1	145	0.80	0.66												
100	28	159	0.75	0.8	131	0.62	0.62												

75	$n_1 = 1400$		XC - XF										XA						
	i_n	n_2 [min ⁻¹]	T_2 [Nm]	P_1 [kW]	FS'	Input - IEC										T_{2M} [Nm]	P [kW]	Rd	P_{t0}
						XC			XF				B14						
						B5/B14			B5				B14						
7.5	187	178	4	1.0	112 100	90	—	112 100	90	80	112 100	90	—	180	4.0	0.87	2.5		
10	140	176	3	1.1										193	3.3	0.86	2.3		
15	93	187	2.2	1.1	202	2.4	0.83	1.9											
20	70	199	1.8	1.1	226	2.0	0.81	1.7											
25	56	200	1.5	1.0	202	1.5	0.78	1.5											
30	47	167	1.1	1.3	220	1.5	0.74	1.2											
40	35	213	1.1	1.1	235	1.2	0.71	1.1											
50	28	206	0.9	1.0	211	0.92	0.67	1.0											
65	22	154	0.55	1.3	195	0.70	0.63	0.90											
80	18	180	0.55	1.0	182	0.55	0.60	0.80											
100	14	210	0.55	0.8	162	0.43	0.56	0.70											

75	$n_1 = 900$		XC - XF										XA						
	i_n	n_2 [min ⁻¹]	T_2 [Nm]	P_1 [kW]	FS'	Input - IEC										T_{2M} [Nm]	P [kW]	Rd	P_{t0}
						XC			XF				B14						
						B5/B14			B5				B14						
7.5	120	205	3	1.0	112 100	90	—	112 100	90	80	112 100	90	—	215	3.1	0.86	—		
10	90	197	2.2	1.2										229	2.6	0.84			
15	60	231	1.8	1.0	237	1.9	0.81												
20	45	250	1.5	1.1	263	1.6	0.78												
25	36	221	1.1	1.1	233	1.2	0.76												
30	30	249	1.1	1.0	254	1.1	0.71												
40	23	214	0.75	1.3	270	0.94	0.67												
50	18	186	0.55	1.3	241	0.71	0.64												
65	14	151	0.37	1.5	221	0.54	0.59												
80	11	177	0.37	1.2	205	0.43	0.56												
100	9	203	0.37	0.9	184	0.34	0.52												

75	$n_1 = 500$		XC - XF										XA						
	i_n	n_2 [min ⁻¹]	T_2 [Nm]	P_1 [kW]	FS'	Input - IEC										T_{2M} [Nm]	P [kW]	Rd	P_{t0}
						XC			XF				B14						
						B5/B14			B5				B14						
7.5	67	90	0.75	2.9	112 100	90	—	112 100	90	80	112 100	90	—	265	2.2	0.84	—		
10	50	118	0.75	2.4										279	1.8	0.82			
15	33	167	0.75	1.7	286	1.3	0.78												
20	25	216	0.75	1.5	315	1.1	0.75												
25	20	260	0.75	1.1	278	0.80	0.72												
30	17	288	0.75	1.1	302	0.79	0.67												
40	13	265	0.55	1.2	317	0.66	0.63												
50	10	210	0.37	1.3	282	0.50	0.59												
65	8	251	0.37	1.0	257	0.38	0.55												
80	6	197	0.25	1.2	238	0.30	0.52												
100	5	161	0.18	1.3	206	0.23	0.47												

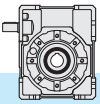

2.5 Dati tecnici

2.5 Technical data

2.5 Technische Daten

90	n₁ = 2800		XC - XF										XA						
	i _n	n ₂ [min ⁻¹]	T ₂ [Nm]	P ₁ [kW]	FS'	Input - IEC										T _{2M} [Nm]	P [kW]	Rd	P _{t0}
						XC			XF				B14						
						B5/B14			B5				B14						
7.5	373	171	7.5	1.2	112 100	90	—	112 100	90	80	112 100	90	—	209	9.2	0.89	—		
10	280	165	5.5	1.3										223	7.4	0.88			
15	187	241	5.5	1.0	241	5.5	0.86												
20	140	230	4	1.2	272	4.7	0.84												
25	112	212	3	1.2	255	3.6	0.83												
30	93	243	3	1.1	270	3.3	0.79												
40	70	230	2.2	1.3	293	2.8	0.77												
50	56	278	2.2	1.0	278	2.2	0.74												
65	43	235	1.5	1.1	250	1.6	0.71												
80	35	205	1.1	1.2	238	1.3	0.68												
100	28	163	0.75	1.3	212	0.97	0.64												

Kg
23.6

90	n₁ = 1400		XC - XF										XA						
	i _n	n ₂ [min ⁻¹]	T ₂ [Nm]	P ₁ [kW]	FS'	Input - IEC										T _{2M} [Nm]	P [kW]	Rd	P _{t0}
						XC			XF				B14						
						B5/B14			B5				B14						
7.5	187	247	5.5	1.2	112 100	90	—	112 100	90	80	112 100	90	—	290	6.5	0.88	3.0		
10	140	236	4	1.3										305	5.2	0.86	2.5		
15	93	256	3	1.2	320	3.7	0.84	2.2											
20	70	334	3	1.1	360	3.2	0.82	2.0											
25	56	299	2.2	1.1	332	2.4	0.80	1.8											
30	47	340	2.2	1.0	350	2.3	0.76	1.5											
40	35	355	1.8	1.1	377	1.9	0.72	1.3											
50	28	353	1.5	1.0	353	1.5	0.69	1.1											
65	22	317	1.1	1.0	317	1.1	0.65	1.0											
80	18	309	0.9	1.0	309	0.90	0.63	1.0											
100	14	217	0.55	1.2	264	0.67	0.58	0.80											

Kg
23.6

90	n₁ = 900		XC - XF										XA						
	i _n	n ₂ [min ⁻¹]	T ₂ [Nm]	P ₁ [kW]	FS'	Input - IEC										T _{2M} [Nm]	P [kW]	Rd	P _{t0}
						XC			XF				B14						
						B5/B14			B5				B14						
7.5	120	206	3	1.7	112 100	90	—	112 100	90	80	112 100	90	—	345	5.0	0.86	—		
10	90	270	3	1.3										362	4.0	0.85			
15	60	286	2.2	1.3	377	2.9	0.82												
20	45	371	2.2	1.1	419	2.5	0.79												
25	36	369	1.8	1.0	385	1.9	0.77												
30	30	416	1.8	1.0	416	1.8	0.73												
40	23	440	1.5	1.0	440	1.5	0.69												
50	18	384	1.1	1.0	398	1.1	0.66												
65	14	319	0.75	1.1	358	0.84	0.62												
80	11	274	0.55	1.2	337	0.68	0.59												
100	9	313	0.55	1.0	313	0.55	0.54												

Kg
23.6

90	n₁ = 500		XC - XF										XA						
	i _n	n ₂ [min ⁻¹]	T ₂ [Nm]	P ₁ [kW]	FS'	Input - IEC										T _{2M} [Nm]	P [kW]	Rd	P _{t0}
						XC			XF				B14						
						B5/B14			B5				B14						
7.5	67	91	0.75	4.7	112 100	90	—	112 100	90	80	112 100	90	—	430	3.6	0.84	—		
10	50	118	0.75	3.7										443	2.8	0.83			
15	33	169	0.75	2.7	456	2.0	0.79												
20	25	219	0.75	2.3	502	1.7	0.76												
25	20	265	0.75	1.7	459	1.3	0.74												
30	17	294	0.75	1.6	483	1.2	0.68												
40	13	371	0.75	1.4	512	1.0	0.65												
50	10	439	0.75	1.1	467	0.80	0.61												
65	8	388	0.55	1.1	417	0.59	0.57												
80	6	305	0.37	1.3	391	0.48	0.54												
100	5	344	0.37	1.0	345	0.37	0.49												

Kg
23.6

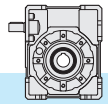

2.5 Dati tecnici

2.5 Technical data

2.5 Technische Daten

110	n₁ = 2800		XC - XF										XA				
	i _n	n ₂ [min ⁻¹]	T ₂ [Nm]	P ₁ [kW]	FS'	Input - IEC								T _{2M} [Nm]	P [kW]	Rd	P _{t0}
						XC			XF								
						B5/B14			B5		B14						
7.5	373	343	15	1.0	132	112 100	—	132	112 100	90	132	—	—	345	15.1	0.89	—
10	280	332	11	1.1										368	12.2	0.88	
15	187	331	7.5	1.2										404	9.2	0.86	
20	140	435	7.5	1.1										465	8.0	0.85	
25	112	393	5.5	1.1										441	6.2	0.84	
30	93	450	5.5	1.0	459	5.6	0.80										
40	70	424	4	1.2	—	90	—	—	—	—	—	—	503	4.7	0.78		
50	56	388	3	1.2									476	3.7	0.76		
65	43	354	2.2	1.2	—	90	—	—	—	—	—	—	417	2.6	0.73		
80	35	287	1.5	1.4									400	2.1	0.70		
100	28	339	1.5	1.1									364	1.6	0.66		



44.0

110	n₁ = 1400		XC - XF										XA				
	i _n	n ₂ [min ⁻¹]	T ₂ [Nm]	P ₁ [kW]	FS'	Input - IEC								T _{2M} [Nm]	P [kW]	Rd	P _{t0}
						XC			XF								
						B5/B14			B5		B14						
7.5	187	415	9.2	1.2	132	112 100	—	132	112 100	90	132	—	—	480	10.6	0.88	4.3
10	140	446	7.5	1.1										504	8.5	0.87	4.0
15	93	475	5.5	1.1										543	6.3	0.84	3.2
20	70	623	5.5	1.0										623	5.5	0.83	3.0
25	56	554	4	1.0										578	4.2	0.81	2.7
30	47	472	3	1.3	—	90	—	—	—	—	—	—	601	3.8	0.77	2.2	
40	35	606	3	1.1									650	3.2	0.74	2.0	
50	28	538	2.2	1.1	—	90	—	—	—	—	—	—	608	2.5	0.72	1.8	
65	22	451	1.5	1.2									528	1.8	0.68	1.6	
80	18	390	1.1	1.3									503	1.4	0.65	1.5	
100	14	458	1.1	1.0	458	1.1	0.61	1.3									



44.0

110	n₁ = 900		XC - XF										XA				
	i _n	n ₂ [min ⁻¹]	T ₂ [Nm]	P ₁ [kW]	FS'	Input - IEC								T _{2M} [Nm]	P [kW]	Rd	P _{t0}
						XC			XF								
						B5/B14			B5		B14						
7.5	120	381	5.5	1.5	132	112 100	—	132	112 100	90	132	—	—	578	8.3	0.87	—
10	90	500	5.5	1.2										600	6.6	0.86	
15	60	526	4	1.2										641	4.9	0.83	
20	45	685	4	1.1										720	4.2	0.81	
25	36	628	3	1.1										672	3.2	0.79	
30	30	520	2.2	1.3	—	90	—	—	—	—	—	—	697	2.9	0.74		
40	23	664	2.2	1.1									749	2.5	0.71		
50	18	653	1.8	1.1	—	90	—	—	—	—	—	—	697	1.9	0.68		
65	14	487	1.1	1.2									603	1.4	0.64		
80	11	570	1.1	1.0									571	1.1	0.61		
100	9	450	0.75	1.1	513	0.85	0.57										



44.0

110	n₁ = 500		XC - XF										XA				
	i _n	n ₂ [min ⁻¹]	T ₂ [Nm]	P ₁ [kW]	FS'	Input - IEC								T _{2M} [Nm]	P [kW]	Rd	P _{t0}
						XC			XF								
						B5/B14			B5		B14						
7.5	67	183	1.5	3.9	132	112 100	—	132	112 100	90	132	—	—	718	5.9	0.85	—
10	50	240	1.5	3.1										738	4.6	0.84	
15	33	344	1.5	2.3										778	3.4	0.80	
20	25	446	1.5	1.9										866	2.9	0.78	
25	20	542	1.5	1.5										802	2.2	0.76	
30	17	603	1.5	1.4	—	90	—	—	—	—	—	—	832	2.1	0.70		
40	13	765	1.5	1.2									886	1.7	0.67		
50	10	671	1.1	1.2	—	90	—	—	—	—	—	—	820	1.3	0.64		
65	8	553	0.75	1.3									705	0.96	0.59		
80	6	643	0.75	1.0									664	0.77	0.56		
100	5	542	0.55	1.1	594	0.60	0.52										



44.0

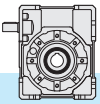

2.6 **Momenti d' inerzia** [Kg·cm²]
(riferiti all'albero veloce in entrata)

2.6 **Moments of inertia** [Kg·cm²]
(referred to input shaft)

2.6 **Trägheitsmoment** [Kg·cm²]
((bez. Antriebswelle))

X30	i_n	XA	XC		XF	
			B5 - B14		B5 - B14	
			IEC 56	IEC 63	IEC 56	IEC 63
7.5	0.058	0.112	0.109	0.102	0.103	
10	0.049	0.103	0.100	0.093	0.094	
15	0.042	0.097	0.094	0.087	0.087	
20	0.039	0.095	0.092	0.084	0.084	
25	0.038	0.094	0.091	0.083	0.083	
30	0.038	0.093	0.090	0.083	0.084	
40	0.037	0.093	0.090	0.082	0.082	
50	0.037	0.092	0.089	0.081	0.082	
65	0.024	0.079	-	0.069	0.069	
80	0.024	0.079	-	0.069	0.069	
100	0.024	0.078	-	0.069	0.069	

X40	i_n	XA	XC			XF		
			B5 - B14			B5	B5 - B14	
			IEC 56	IEC 63	IEC 71	IEC 56	IEC 63	IEC 71
7.5	0.170	-	0.321	0.356	0.217	0.375	0.391	
10	0.144	-	0.272	0.347	0.190	0.348	0.365	
15	0.125	-	0.266	0.340	0.171	0.329	0.346	
20	0.094	-	0.263	0.338	0.141	0.298	0.315	
25	0.091	-	0.262	0.337	0.137	0.295	0.312	
30	0.113	-	0.262	0.337	0.160	0.318	0.335	
40	0.087	-	0.261	-	0.134	0.292	0.309	
50	0.087	-	0.261	-	0.133	0.291	0.308	
65	0.069	0.182	0.261	-	0.116	0.274	0.290	
80	0.069	0.182	0.261	-	0.115	0.273	0.290	
100	0.068	0.182	0.261	-	0.115	0.273	0.290	

X50	i_n	XA	XC			XF		
			B5 - B14			B5	B5 - B14	
			IEC 63	IEC 71	IEC 80	IEC 63	IEC 71	IEC 80
7.5	0.499	-	0.684	0.935	0.733	0.750	1.313	
10	0.417	-	0.602	0.853	0.651	0.668	1.231	
15	0.358	-	0.543	0.794	0.593	0.609	1.173	
20	0.281	-	0.523	0.774	0.516	0.532	1.096	
25	0.272	-	0.513	0.764	0.506	0.523	1.086	
30	0.323	-	0.508	0.759	0.557	0.574	1.137	
40	0.262	-	0.503	-	0.496	0.513	1.076	
50	0.183	-	0.501	-	0.417	0.434	0.997	
65	0.136	0.311	0.499	-	0.370	0.387	0.950	
80	0.136	0.310	0.498	-	0.370	0.387	0.950	
100	0.135	0.309	0.498	-	0.370	0.386	0.950	

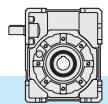

X63	i_n	XA	XC			XF		
			B5 - B14			B5	B5 - B14	
			IEC 71	IEC 80	IEC 90	IEC 71	IEC 80	IEC 90
7.5	1.363	-	1.949	2.269	2.142	2.276	3.354	
10	1.158	-	1.744	2.063	1.936	2.070	3.148	
15	1.011	-	1.597	1.916	1.789	1.924	3.001	
20	0.710	-	1.545	1.864	1.489	1.623	2.701	
25	0.679	-	1.514	1.833	1.458	1.592	2.670	
30	0.922	-	1.508	1.828	1.701	1.835	2.913	
40	0.660	-	1.495	-	1.439	1.573	2.651	
50	0.653	-	1.488	-	1.431	1.565	2.643	
65	0.552	0.955	1.484	-	1.330	1.465	2.542	
80	0.550	0.953	1.482	-	1.329	1.463	2.541	
100	0.549	0.952	1.481	-	1.327	1.462	2.539	









2.6 **Momenti d' inerzia** [Kg·cm²]
(riferiti all'albero veloce in entrata)

2.6 **Moments of inertia** [Kg·cm²]
(referred to input shaft)

2.6 **Trägheitsmoment** [Kg·cm²]
((bez. Antriebswelle))

X75	i_n	XA 	XC 			XF 		
			B5 - B14			B5	B5 - B14	
			IEC 80	IEC 90	IEC 100-112	IEC 80	IEC 90	IEC 100-112
7.5	2.970	-	3.712	4.462	5.138	5.066	6.837	
10	2.492	-	3.234	3.984	4.661	4.588	6.359	
15	2.151	-	2.893	3.643	4.320	4.247	6.018	
20	1.567	-	2.774	3.523	3.735	3.662	5.433	
25	1.501	-	2.709	3.458	3.670	3.597	5.368	
30	1.946	-	2.689	3.438	4.115	4.042	5.813	
40	1.451	-	2.659	-	3.620	3.547	5.318	
50	1.435	-	2.642	-	3.603	3.531	5.302	
65	1.158	1.569	2.633	-	3.326	3.253	5.024	
80	1.153	1.565	2.629	-	3.322	3.249	5.020	
100	1.150	1.562	2.626	-	3.318	3.246	5.017	

X90	i_n	XA 	XC 			XF 		
			B5 - B14			B5	B5 - B14	
			IEC 80	IEC 90	IEC 100-112	IEC 80	IEC 90	IEC 100-112
7.5	6.167	-	6.898	7.671	8.335	8.263	10.033	
10	5.143	-	5.875	6.648	7.312	7.239	9.010	
15	4.413	-	5.144	5.917	6.581	6.508	8.279	
20	2.653	-	3.398	5.661	4.821	4.749	6.519	
25	2.511	-	3.256	5.520	4.680	4.607	6.378	
30	3.974	-	3.215	5.479	6.142	6.070	7.841	
40	2.406	-	3.151	-	4.574	4.502	6.273	
50	2.371	-	3.115	-	4.539	4.467	6.237	
65	1.672	2.024	3.096	-	3.841	3.768	5.539	
80	1.663	2.014	3.087	-	3.831	3.759	5.530	
100	1.656	2.008	3.080	-	3.825	3.752	5.523	

X110	i_n	XA 	XC 			XF 			
			B5 - B14			B5		B5 - B14	
			IEC 90	IEC 100-112	IEC 132	IEC 80	IEC 90	IEC 100-112	IEC 132
7.5	16.247	-	17.980	20.038	20.584	20.535	20.711	22.704	
10	13.386	-	15.119	17.177	17.723	17.674	17.851	19.843	
15	11.343	-	13.076	15.134	15.679	15.631	15.807	17.799	
20	6.655	-	8.367	14.418	10.992	10.943	11.120	13.112	
25	6.257	-	7.969	14.020	10.594	10.545	10.722	12.714	
30	10.117	-	11.850	13.908	14.453	14.405	14.581	16.573	
40	5.965	-	7.677	-	10.302	10.254	10.430	12.422	
50	5.866	-	7.578	-	10.203	10.154	10.330	12.323	
65	3.792	5.592	7.510	-	8.128	8.080	8.256	10.248	
80	3.770	5.570	7.489	-	8.107	8.059	8.235	10.227	
100	3.755	5.555	7.474	-	8.092	8.044	8.220	10.212	

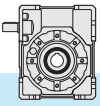

2.7 Dimensioni

2.7 Dimensions

2.7 Abmessungen

XA

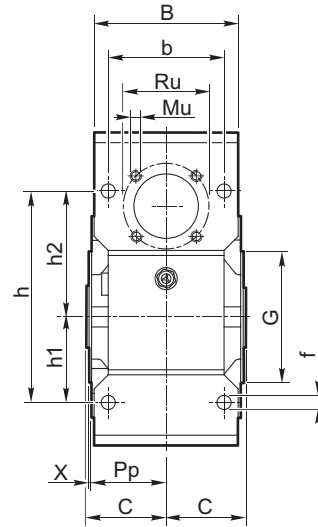
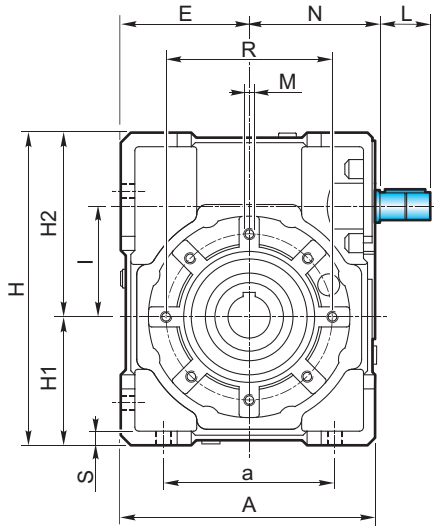

XF

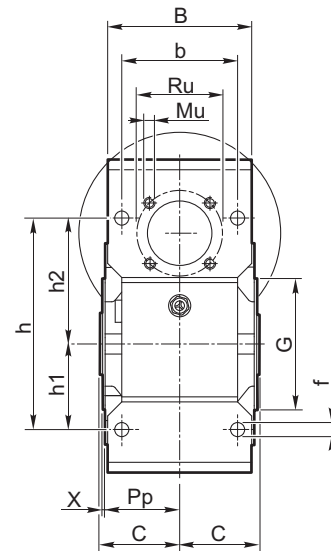
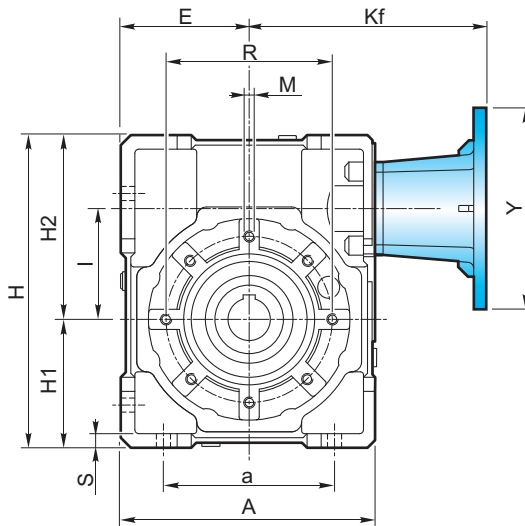

XC

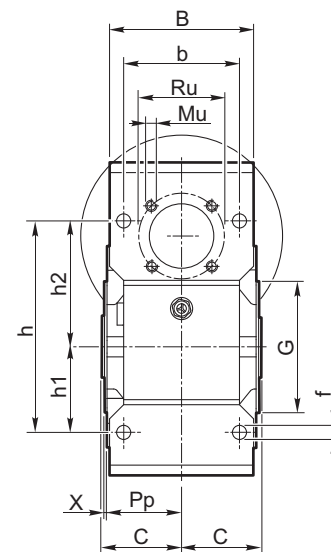
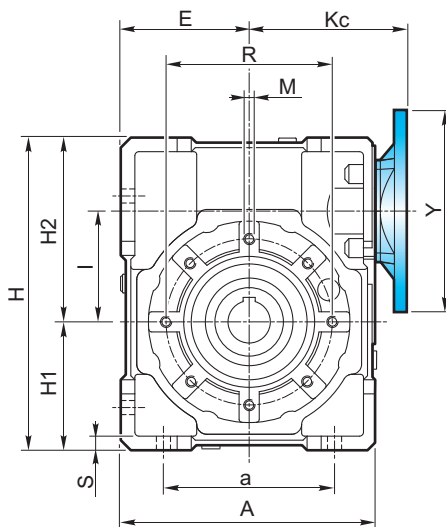

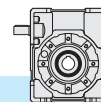

2.7 Dimensioni

2.7 Dimensions

2.7 Abmessungen

Flangia pendolare / Shaft-mounted flange / Aufsteckflansch

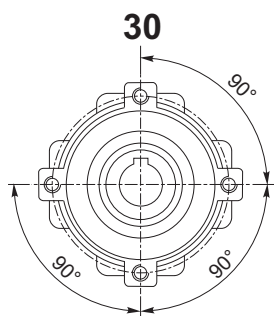

4 Fori / Holes / Bohrungen

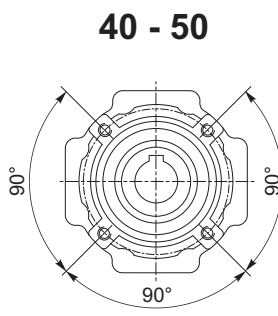

4 Fori / Holes / Bohrungen

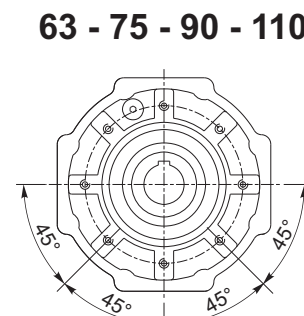

8 Fori / Holes / Bohrungen

Albero uscita cavo
Output hollow shaft
Abtriebshohlwelle

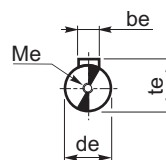
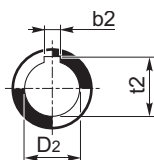

Albero entrata
Input shaft
Antriebswelle

X	A	a	B	b	b _e	b ₂	C	d _e j ₆	D ₂ H ₇	E	f	G h ₈	H	H ₁	H ₂	h	h ₁	h ₂		
30	80	54	56	44	3	5	—	31.5	9	14	—	40	6.5	55	97	40	57	71	27	44
40	105	70	71	60	4	6	6	39	11	18	19	50	6.5	60	125	50	75	90	35	55
50	125	80	85	70	5	8	8	46	14	25	24	60	8.5	70	150	60	90	104	40	64
63	147	100	103	85	6	8	—	56	19	25	—	72	9	80	182	72	110	130	50	80
75	176	120	112	90	8	8	—	60	24	28	—	86	11	95	219.5	86	133.5	153	60	93
90	203	140	130	100	8	10	—	70	24	35	—	103	13	110	248.5	103	145.5	172	70	102
110	252.5	170	143	115	8	12	—	77.5	28	42	—	127.5	14	130	310.5	127.5	183	210	85	125

X	l	K _c	L	M	M _e	M _u	N	P _p	R	Ru	S	t _e	t ₂	X	
30	31.5	57	15	M6x8	M4x10	M5x7.5	44.5	29	65	35.4	5.5	10.2	16.3	—	1.5
40	40	75	20	M6x10	M4x12	M5x10	57.5	36.5	75	42.4	6	12.5	20.8	21.8	1.5
50	50	82	25	M8x10	M5x13	M6x10	67.5	43.5	85	53.7	7	16	28.3	27.3	1.5
63	63	95	30	M8x14	M8x20	M6x12	77.5	53	95	60.8	8	21.5	28.3	—	2
75	75	112	40	M8x14	M8x20	M8x12	95	57	115	70.7	10	27	31.3	—	2
90	90	122	40	M10x18	M8x20	M8x14	105	67	130	70.7	12	27	38.3	—	2
110	110	153	50	M10x18	M8x20	M10x18	130	74	165	85.0	14	31	45.3	—	2.5

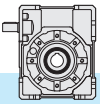

Flangia uscita

Output flange

Abtriebsflansch

Vista da A / View from A / Ansicht von A

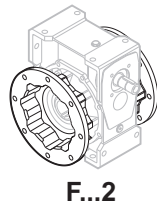
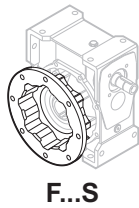
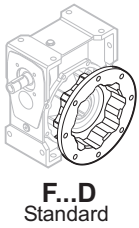
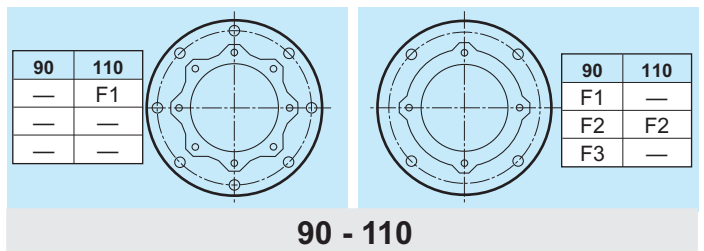
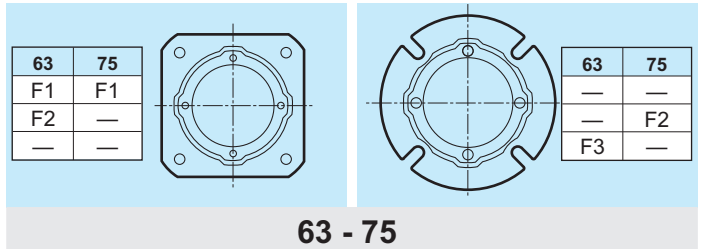
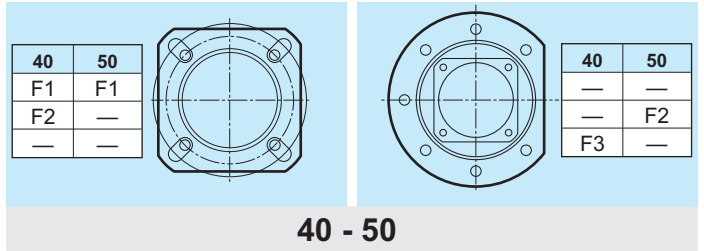
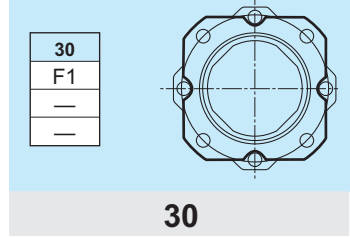
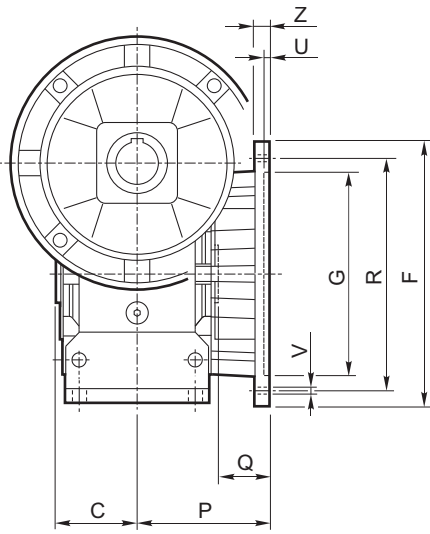

Tipo Type Typ	C	F		G H8	P	Q	R	U	V			Z		
													Ø	
30	31.5			66	50	54.5	23	68	4	n* 4	6.5	6		
		F1												
		F2												
40	39			85	60	67	28	75-90	4	n* 4	9	8		
		F1												
		F2			85	60	97	58	75-90	4	n* 4	9	8	
50	46		140	95	80	41	115	5		n* 7	9	10		
		F1			94	70	90	44	85-95	5	n* 4	11	10	
		F2			160	110	89	43	130	5	n* 7	11	11	
63	56			142	115	82	26	150	5	n* 4	11	11		
		F1												
		F2			142	115	112	56	150	5	n* 4	11	11	
75	60			160	110	80.5	24.5	130	5	n* 4	11	12		
		F1			160	130	111	51	165	5	n* 4	13	12	
		F2			160	110	90	30	130	6	n* 4	11	13	
90	70			200	152	111	41	175	5	n* 4	13	12		
		F1												
		F2			200	152	151	81	175	5	n* 4	13	13	
110	77.5			200	130	110	40	165	6	n* 4	11	11		
		F1			260	170	131	53.5	230	6		n* 8	13	15
		F2			250	180	150	72.5	215	5	n* 4	15	16	

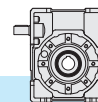

2.7 Dimensioni

2.7 Dimensions

2.7 Abmessungen

Flangia entrata / Input flange / Antriebsflansch



PM = 1

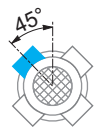

PM = 2

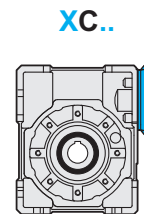
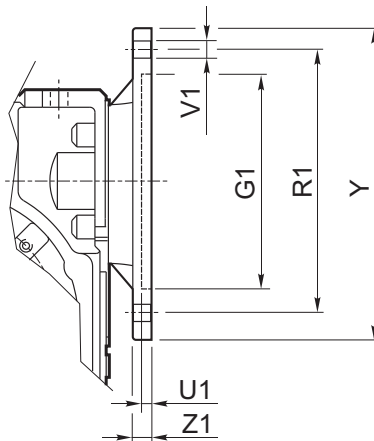

XC	IEC	G ₁ H7	PM		R ₁	U ₁	V ₁			Y	Z ₁	Diametro fori PAM / Holes diameter IEC / IEC Durchmesser												
			1	2			Ø	Ø	Ø			7.5	10	15	20	25	30	40	50	65	80	100		
30	56 B5	80	•	•	100	4	7	8		120	8	9	9	9	9	9	9	9	9	9	9	9	9	
	56 B14	50		•	65	3.5	6		4	80	8	9	9	9	9	9	9	9	9	9	9	9	9	
	63 B5	95	•	•	115	4	9	8		140	8	11	11	11	11	11	11	11	11	11	/	/	/	
	63 B14	60	•	•	75	4	6	8		90	8	11	11	11	11	11	11	11	11	11	/	/	/	
40	56 B5	80	•	•	100	4	7	8		120	9	/	/	/	/	/	/	/	/	/	/	9	9	9
	56 B14	50		•	65	3.5	6		4	80	8	/	/	/	/	/	/	/	/	/	/	9	9	9
	63 B5	95	•	•	115	4	9	8		140	9	11	11	11	11	11	11	11	11	11	11	11	11	11
	63 B14	60		•	75	3.5	6		4	90	8	11	11	11	11	11	11	11	11	11	11	11	11	11
	71 B5	110	•	•	130	4.5	9	8		160	10	14	14	14	14	14	14	14	14	14	/	/	/	/
	71 B14	70		•	85	3.5	7		4	105	8	14	14	14	14	14	14	14	14	14	/	/	/	/
50	63 B5	95	•	•	115	4	9	8		140	9	/	/	/	/	/	/	/	/	/	/	11	11	11
	63 B14	60		•	75	3.5	6		4	90	8	/	/	/	/	/	/	/	/	/	/	11	11	11
	71 B5	110	•	•	130	4.5	9	8		160	10	14	14	14	14	14	14	14	14	14	14	14	14	14
	71 B14	70		•	85	3.5	7		4	105	8	14	14	14	14	14	14	14	14	14	14	14	14	14
	80 B5	130	•	•	165	4.5	11	8		200	10	19	19	19	19	19	19	19	19	19	/	/	/	/
	80 B14	80		•	100	4	7	8		120	10	19	19	19	19	19	19	19	19	19	/	/	/	/
63	71 B5	110	•	•	130	4.5	9	8		160	10	/	/	/	/	/	/	/	/	/	/	14	14	14
	71 B14	70		•	85	3.5	7		4	105	10	/	/	/	/	/	/	/	/	/	/	14	14	14
	80 B5	130	•	•	165	4.5	11	8		200	10	19	19	19	19	19	19	19	19	19	19	19	19	19
	80 B14	80		•	100	4	7		4	120	10	19	19	19	19	19	19	19	19	19	19	19	19	19
	90 B5	130	•	•	165	4.5	11	8		200	10	24	24	24	24	24	24	24	24	24	/	/	/	/
	90 B14	95	•	•	115	4	8.5	8		140	10	24	24	24	24	24	24	24	24	24	/	/	/	/
75	80 B5	130	•	•	165	4.5	11	8		200	10	/	/	/	/	/	/	/	/	/	/	19	19	19
	80 B14	80		•	100	4	7		4	120	11	/	/	/	/	/	/	/	/	/	/	19	19	19
	90 B5	130	•	•	165	4.5	11	8		200	10	24	24	24	24	24	24	24	24	24	24	24	24	24
	90 B14	95		•	115	4	9		4	140	11	24	24	24	24	24	24	24	24	24	24	24	24	24
	100/112 B5	180	•	•	215	5	14	8		250	13	28	28	28	28	28	28	28	28	28	/	/	/	/
	100/112 B14	110	•	•	130	4.5	9	8		160	11	28	28	28	28	28	28	28	28	28	/	/	/	/
90	80 B5	130	•	•	165	4.5	11	8		200	10	/	/	/	/	/	/	/	/	/	/	19	19	19
	80 B14	80		•	100	4	7		4	120	11	/	/	/	/	/	/	/	/	/	/	19	19	19
	90 B5	130	•	•	165	4.5	11	8		200	10	24	24	24	24	24	24	24	24	24	24	24	24	24
	90 B14	95		•	115	4	9		4	140	11	24	24	24	24	24	24	24	24	24	24	24	24	24
	100/112 B5	180	•	•	215	5	14	8		250	13	28	28	28	28	28	28	28	28	28	/	/	/	/
	100/112 B14	110	•	•	130	4.5	9	8		160	11	28	28	28	28	28	28	28	28	28	/	/	/	/
110	90 B5	130	•		165	5	11	4		200	12	/	/	/	/	/	/	/	/	/	24	/	24	24
	90 B14	95		•	115	5	9		4	140	12	/	/	/	/	/	/	/	/	/	24	/	24	24
	100/112 B5	180	•		215	5	14	4		250	14	28	28	28	28	28	28	28	28	28	28	28	28	28
	100/112 B14	110		•	130	5	9		4	160	12	28	28	28	28	28	28	28	28	28	28	28	28	28
	132 B5	230	•		265	5	14	4		300	14	38	38	38	38	38	38	38	38	38	/	/	/	/
	132 B14	130	•		165	5	11	4		200	12	38	38	38	38	38	38	38	38	38	/	/	/	/

N.B.: Il montaggio STD di P_M=2 solo quando non è possibile il montaggio STD di P_M=1.

N.B.: STD mounting of P_M=2 only if STD mounting of P_M=1 is not possible.

ANMERKUNG: STD Montage von P_M=2 nur wenn STD Montage von P_M=1 unmöglich ist.

N.B.: E' possibile realizzare anche tutte le composizioni ibride ottenibili dalle flange esistenti.

N.B.: it is possible to create hybrid combinations with the existing flanges.

ANMERKUNG: Mischkombinationen mit der verfügbaren Flanschen sind möglich.

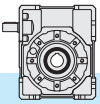

Flangia entrata / Input flange / Antriebsflansch

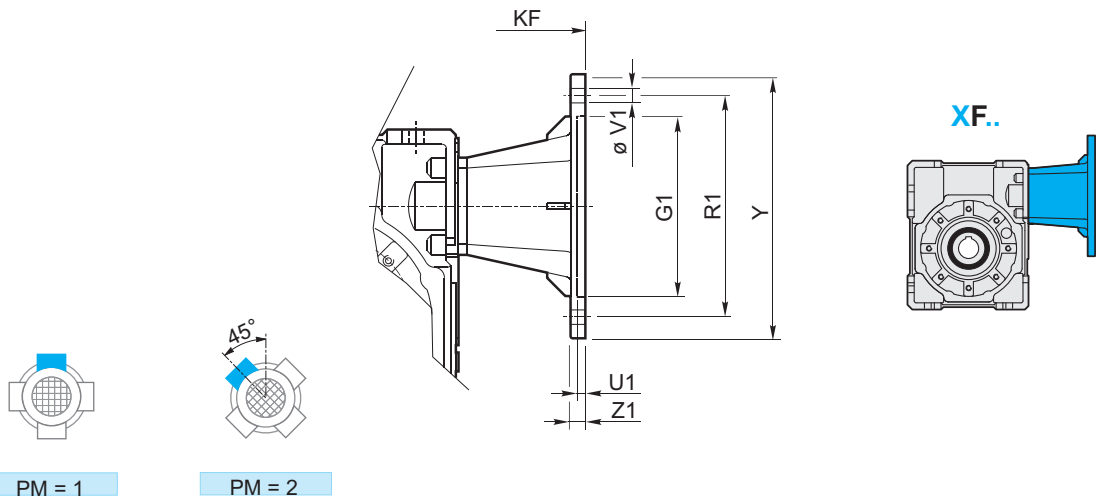

XF	IEC	PM		G ₁ H7	K _F	R ₁	U ₁	V ₁			Y	Z ₁	
		1	2										
30	56 B5	•	•	80	82.5	100	3.5	7		8		120	8
	56 B14		•	50	82.5	65	3.5	6			4	80	8
	63 B5	•	•	95	85.5	115	4	9		8		140	10
	63 B14	•	•	60	85.5	75	3.5	6		8		90	8
40	56 B5	•	•	80	101.5	100	3.5	7		8		120	8
	63 B5	•	•	95	104.5	115	4	9		8		140	10
	63 B14	•	•	60	104.5	75	3.5	6		8		90	8
	71 B5	•	•	110	111.5	130	4.5	9		8		160	10
	71 B14	•	•	70	111.5	85	4	7		8		105	10
50	63 B5	•	•	95	119.5	115	4	9		8		140	10
	71 B5	•	•	110	126.5	130	4.5	9		8		160	10
	71 B14		•	70	126.5	85	3.5	7			4	105	10
	80 B5	•	•	130	136.5	165	4.5	11		8		200	10
	80 B14	•	•	80	136.5	100	4	7		8		120	10
63	71 B5	•	•	110	141.5	130	4.5	9		8		160	10
	80/90 B5	•	•	130	161.5	165	4.5	11		8		200	10
	80 B14	•	•	80	151.5	100	4	7		8		120	10
	90 B14	•	•	95	161.5	115	4	9		8		140	10
75	80/90 B5	•	•	130	190	165	4.5	11		8		200	10
	90 B14		•	95	190	115	4	9			4	140	10
	100/112 B5	•	•	180	200	215	5	14		8		250	14
	100/112 B14	•	•	110	200	130	4.5	9		8		160	10
90	80/90 B5	•	•	130	200	165	4.5	11		8		200	10
	90 B14		•	95	200	115	4	9			4	140	10
	100/112 B5	•	•	180	210	215	5	14		8		250	14
	100/112 B14	•	•	110	210	130	4.5	9		8		160	10
110	80/90 B5	•	•	130	235	165	4.5	11	4			200	12
	100/112 B5	•	•	180	245	215	5	14	4			250	14
	132 B5	•	•	230	266	265	5	14	4			300	16
	132 B14	•	•	130	266	165	4.5	11	4			200	12

N.B.: Il montaggio STD di P_M=2 solo quando non è possibile il montaggio STD di P_M=1.

N.B.: STD mounting of P_M=2 only if STD mounting of P_M=1 is not possible.

ANMERKUNG: STD Montage von P_M=2 nur wenn STD Montage von P_M=1 unmöglich ist.

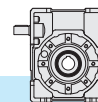

2.8 **Entrata supplementare**
(vite bisporgente)

2.8 **Additional input**
(double extended shaft)

2.8 **Zusatzantrieb**
(beidseitige Welle)

S.e.A.

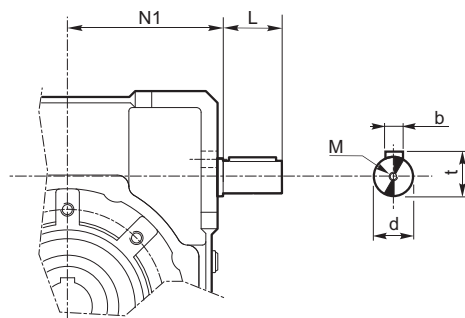

X	d j6	L	M	N1	b	t
30	9	15	M4x10	42.5	3	10.2
40	11	20	M4x12	52.5	4	12.5
50	14	25	M5x13	62.5	5	16
63	19	30	M8x20	74.5	6	21.5
75	24	40	M8x20	91	8	27
90	24	40	M8x20	108	8	27
110	28	50	M8x20	132.5	8	31

2.9 **Limitatore di coppia**
cavo passante

2.9 **Torque limiter with through**
hollow shaft

2.9 **Drehmomentbegrenzer**
mit durchgehender Hohlwelle

Il limitatore di coppia viene consigliato in tutte quelle applicazioni che richiedono una limitazione sulla coppia trasmissibile per proteggere l'impianto e/o preservare il riduttore evitando sovraccarichi o urti indesiderati quanto inaspettati.

È un dispositivo con albero dotato di cavo passante, con funzionamento a frizione, ed è integrato al riduttore, presentando un ingombro limitato.

Concepito per lavorare a bagno d'olio, il dispositivo risulta affidabile nel tempo ed è esente da usura se non viene mantenuto in condizioni prolungate di slittamento (condizione che si verifica quando la coppia presenta valori superiori a quelli di taratura).

La taratura è facilmente regolabile dall'esterno attraverso il serraggio di una ghiera autobloccante che porta a compressione le 4 molle a tazza disposte tra loro in serie.

Il dispositivo non consente:

- l'impiego di cuscinetti a rulli conici in uscita
- funzionamento prolungato in condizioni di slittamento.

Nella tabella seguente vengono riportati i valori delle coppie di slittamento M_{2S} in funzione del n° di giri della ghiera.

I valori di taratura presentano una tolleranza del $\pm 10\%$ e si riferiscono ad una condizione statica.

In condizioni dinamiche è da notare che la coppia di slittamento assume valori diversi a seconda del tipo e/o modalità in cui si verifica il sovraccarico: con valori maggiori in caso di carico uniformemente crescente rispetto a valori più contenuti in seguito al verificarsi di picchi improvvisi di carico.

NOTA: quando si supera il valore di taratura si ha slittamento.

Il coefficiente di attrito tra le superfici di contatto da statico diventa dinamico e la coppia trasmessa cala del 30% circa.

E' quindi opportuno prevedere uno stop per poter ripartire al valore di taratura iniziale.

The use of a torque limiter is advised when the application requires the limitation of the transmissible torque to safeguard the plant and/or the prevention of unexpected and undesired overloads or shocks which might damage the gearbox.

The torque limiter is a device equipped with through hollow shaft and a friction clutch. It is integrated with the gearbox, therefore the space requirement is limited.

Designed to work in oil bath, the device is reliable over time and is not subject to wear unless kept under conditions of prolonged slipping (it occurs when the torque values are higher than the calibration values).

Calibration can be easily adjusted from outside by tightening the self-locking ring nut which causes the compression of the 4 Belleville washers arranged in series.

The device does not go together with:

- the use of tapered roller bearings at output
- Prolonged operation under slipping conditions.

The following table shows the values of M_{2S} slipping torques depending on the number of revolutions of the ring nut.

Calibration values feature a $\pm 10\%$ tolerance and refer to static conditions.

Under dynamic conditions, the values of the slipping torque differ depending to the type of overload: the values are higher if the load increase is uniform, the values are lower if sudden load peaks occur.

NOTE: *Slipping occurs when the setting values are exceeded.*

The friction coefficient between the contact surfaces from static becomes dynamic and the transmitted torque is approx. 30% lower.

It is advisable to have a stop first in order to have a restart based on the initial setting value.

Die Anwendung eines Drehmomentbegrenzers wird empfohlen, um die Anlage und/oder das Getriebe gegen ungewünschte und unerwartete Überbelastungen oder Stoßen zu schützen.

Die Vorrichtung verfügt über eine Welle mit durchgehender Hohlwelle und eine Kupplung. Er ist in dem Getriebe integriert, d.h. der Raumbedarf ist klein.

Der Drehmomentbegrenzer wurde für Betrieb in einem Ölbad entworfen. Er ist zuverlässig über Zeit und verschleissfest (ausser wenn Rutschen für lange Zeit besteht: das passiert, wenn das Drehmoment höher als der Eichwert ist).

Die Eichung darf mühelos von aussen durch das Anziehen einer selbstsperrenden Mutter ausgeführt werden.

Das Anziehen verursacht die Zusammenrückung der 4 wechelsinnigeschichteten Tellerfeder.

Der Begrenzer sieht das folgende nicht vor:

- die Verwendung von Kegelrollenlager am Abtrieb
- Längerer Rutschbetrieb.

Die nachstehende Tabelle zeigt die Werte der Rutschmomente M_{2S} abhängig von der Zahl der Umdrehungen der Mutter.

Die Eichwerte weisen $\pm 10\%$ Toleranz auf und beziehen sich auf statische Bedingungen.

Unter dynamischen Bedingungen hat das Rutschmoment verschiedene Werte je nach Art der Überbelastung. Die Werte sind höher, wenn die Belastung gleichmäßig zunimmt; sie sind niedriger im Falle von plötzlichen Belastungsspitzen.

BEMERKUNG: Rutschen tritt auf, wenn die eingestellten Werte überschritten werden. Der Reibungsfaktor zwischen den Berührungsflächen wird dynamisch anstatt statisch und das übertragene Drehmoment sinkt um ca. 30%.

Es ist daher ratsam, vor dem erneuten Anfahren anzuhalten, um die ursprünglichen Drehmomentwerte zu erreichen.

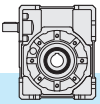

E' importante notare che la coppia di slittamento non resta sempre la medesima durante tutta la vita del limitatore.

Tende infatti a diminuire in rapporto al numero e alla durata degli slittamenti che, rodando le superfici di contatto, ne aumentano il rendimento.

E' quindi opportuno verificare periodicamente, soprattutto durante la fase di rodaggio, la taratura del dispositivo.

Là dove sia richiesto un errore più contenuto nella taratura, è necessario testare la coppia trasmissibile sull' impianto.

Il dispositivo viene consegnato tarato alla coppia riportata a catalogo T_{2M} salvo diversa indicazione espressa in fase di ordinazione.

It is important to note that the slipping torque is not the same for the whole life of the torque limiter. It usually decreases in connection with the numbers and the duration of the slipping which because of the surfaces' lapping will increase the efficiency.

For this reason it is advisable to check the calibration of the device at regular intervals, specially during the running-in period. Should a smaller calibration error be required, it is necessary to test the transmissible torque on the plant.

The device is supplied already calibrated at the torque reported in the catalogue T_{2M} , unless otherwise specified in the order.

Es ist wichtig zu beachten, dass das Rutschmoment über die gesamte Lebensdauer der Rutschkupplung nicht konstant bleibt, sondern üblicherweise in Verbindung mit längeren Rutschzyklen aufgrund der eingelaufenen Berührungsflächen abnimmt.

Deswegen ist es ratsam, die Eichung der Vorrichtung besonders während der Einlaufzeit zu prüfen.

Falls ein niedriger Eichfehler verlangt wird, ist das übersetzbare Drehmoment auf der Anlage zu testen.

Wenn die Vorrichtung geliefert wird, ist sie schon auf dem im Katalog T_{2M} angegebenen Drehmoment geeicht, ausser wenn es in der Bestellung anders angegeben wird.

X	N°. giri della ghiera di regolazione / N°. revolutions of ring nut / Nr. Umdrehungen der Mutter										
	1 1/4	1 1/2	1 3/4	2	2 1/4	2 1/2	2 3/4	3	3 1/4	3 1/2	3 3/4
	M_{2S} [Nm]										
30	15	20	23	25							
40	37	45									
50	45	55	63	70	77						
63			85	95	110	125	137	150			
75					147	165	177	190	205	220	230
90			193	220	247	275	297	320	350	380	
110	425	550	600	700							

Disposizione delle molle
Washers' arrangement
Lage der Feder

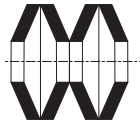

IN SERIE (min. coppia, max. sensibilità)
SERIES (min. torque, max sensitivity)
SERIE (min. Moment, max. Empfindlichkeit)

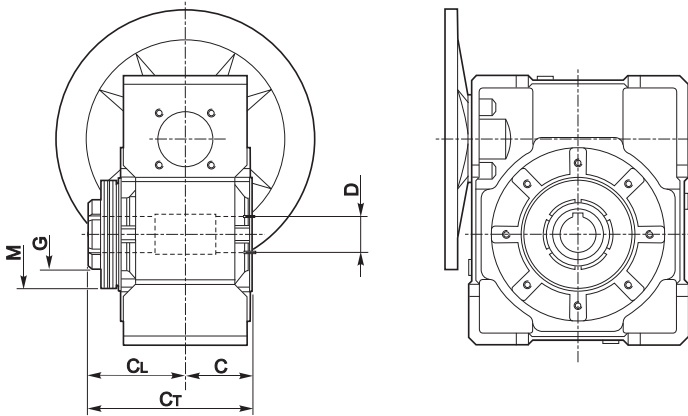

X	C	C _L	C _t	D _{H7}	M	G
30	31.5	55.5	87	14	50x25.4x1.25	M25x1.5
40	39	65	104	18 (19)	56x30.5x1.5	M30x1.5
50	46	76	122	25 (24)	63x40.5x1.8	M40x1.5
63	56	91	147	25	71x40.5x2	M40x1.5
75	60	100	160	28 (30)	90x50.5x2.5	M50x1.5
90	70	109	179	35 (32)	100x51x2.7	M50x1.5
110	77.5	127.5	205	42	125x61x4	M60x2.0

() A richiesta / On request / Auf Anfrage

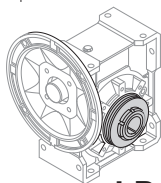

LD

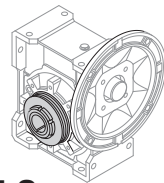

LS

Nella versione con limitatore non è prevista la fornitura degli alberi lenti.

The version with torque limiter is supplied without output shafts.

Die Version mit Drehmomentbegrenzer wird ohne Abtriebswellen geliefert.

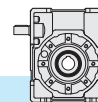

2.10 Accessori

2.10 Accessories

2.10 Zubehör

Albero lento

Output shaft

Abtriebswelle

Albero lento semplice
Single output shaft
Standard Abtriebswelle

Albero lento doppio
Double output shaft
Doppelte Abtriebswelle

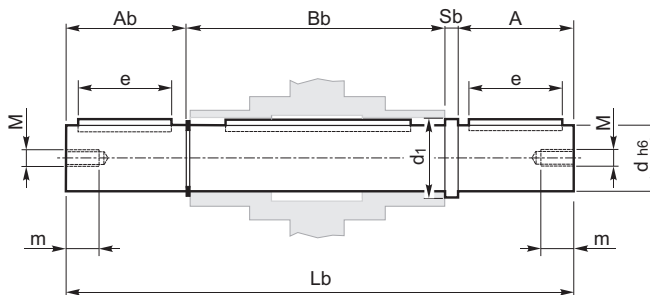
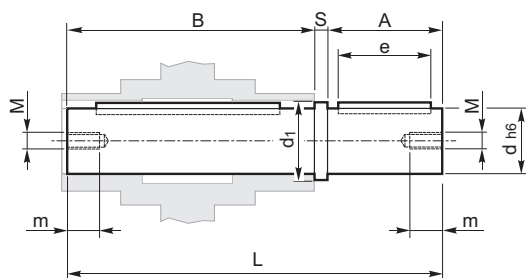

X	A	A _b	B	B _b	d h6	d ₁	e	L	L _b	M	m	S	S _b
30	30	29	62	64	14	18.5	20	94.5	126	M6	16	2.5	2.5
40	40	39	77	79	18	23.5	30	120	161	M6	16	3	3
50	50	49	90	93	25	31.5	40	143.5	195.5	M8	22	3.5	3.5
63	50	49	111	113	25	31.5	40	165	216	M8	22	4	4
75	60	59	119	121	28	34.5	50	183	244	M8	22	4	4
90	80	78.5	139	141.5	35	41.5	60	224	305	M10	28	5	5
110	80	77.5	154.5	157	42	49.5	60	242.5	322.5	M10	28	8	8

Braccio di reazione

Torque arm

Drehmomentstütze

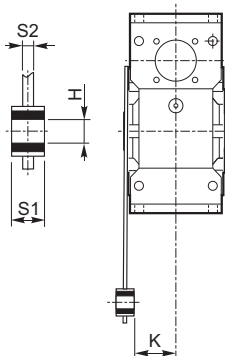
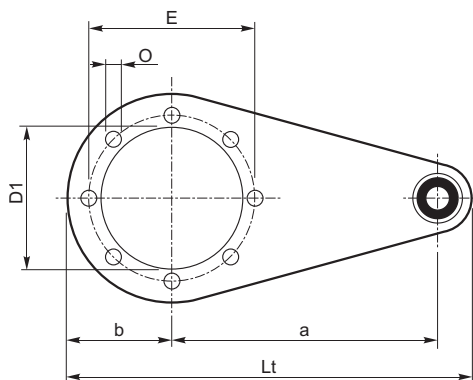

X	a	b	D ₁	E	H	K	L _t	O	S1	S2
30	85	37.5	55	65	8	24	141.5	7	14	4
40	100	45	60	75	10	31.5	167	7	14	4
50	100	50	70	85	10	39	172	9	14	5
63	150	55	80	95	10	49	227	9	14	6
75	200	70	95	115	20	47.5	302	9	25	6
90	200	80	110	130	20	57.5	312	11	25	6
110	250	100	130	165	25	62	390	11	30	6

Kit di protezione:

Protection Kit:

Schutzvorrichtung

Albero cavo / Hollow shaft / Hohlwelle

Limitatore di coppia / Torque limiter / Drehmomentbegrenzer

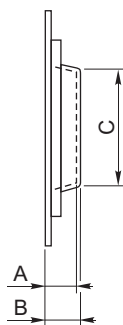

X	A	B	C
30	12	13	39
40	14	15.5	44
50	15	16.5	54
63	17	19	60
75	18	20	70
90	21.5	24	80
110	22	25	96

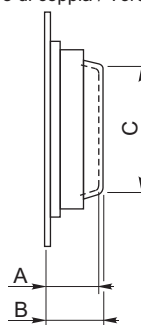

X	A	B	C
30	36	37	36
40	40	41.5	44
50	47	48.5	53
63	52	54	55
75	58	60	68
90	60.5	63	70
110	72	75	85

Opzioni disponibili:

Available options:

Auf Anfrage ist folgendes Zubehör erhältlich:

Cuscinetti a rulli conici corona

Tapered roller bearing for worm wheel

Kegelrollenlager für Schneckenrad

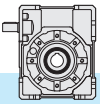

XA - XF

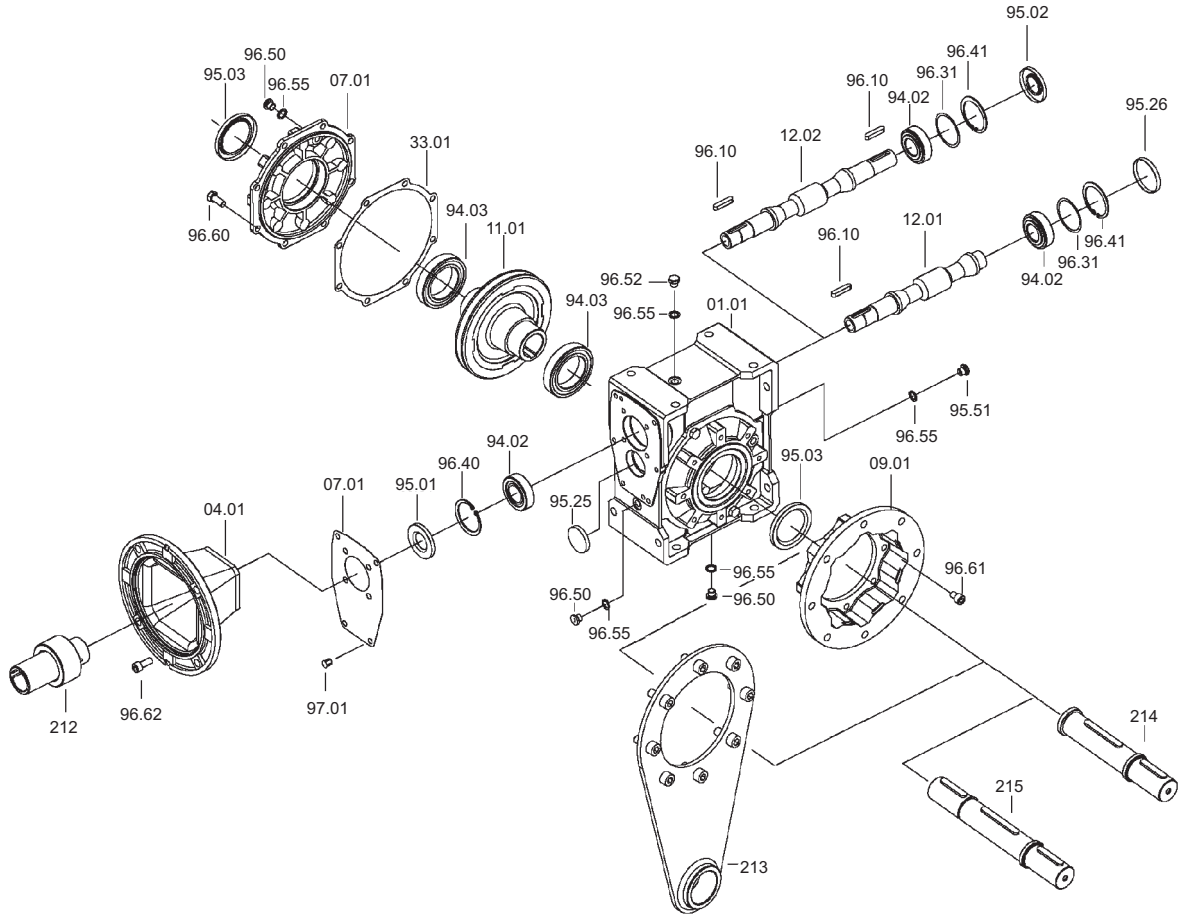

X	Cuscinetti / Bearings / Lager		Anelli di tenuta / Oilseals Öldichtungen			Cappellotto / Closed oil seal Geschlossene Öldichtung	
	94.02	94.03	95.01	95.02	95.03	95.25	95.26
30	6000 10x26x8	6005 25x47x12	10/26/7	10/26/7	25/40/7	—	ø 6x7
40	6201 12x32x10	6006 30x55x13	12/32/7	12/32/7	30/47/7	—	ø 32x7
50	6203 17x40x12	6008 40x68x15	17/40/7	17/40/7	40/62/8	—	ø 40x7
63	30204 20x47x15.25	6008 40x68x15	20/47/7	20/47/7	40/62/8	—	ø 47x7
75	30205 25x52x16.25	6010 50x80x16	25/52/7	25/52/7	50/72/8	—	ø 52x7
90	32205 25x52x19.25	6010 50x80x16	25/52/7	25/52/7	50/72/8	ø 35x5	ø 52x7
110	32206B 30x62x21.25	6012 60x95x18	30/62/7	30/62/7	60/85/8	ø 47x7	ø 62x7

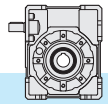

XC

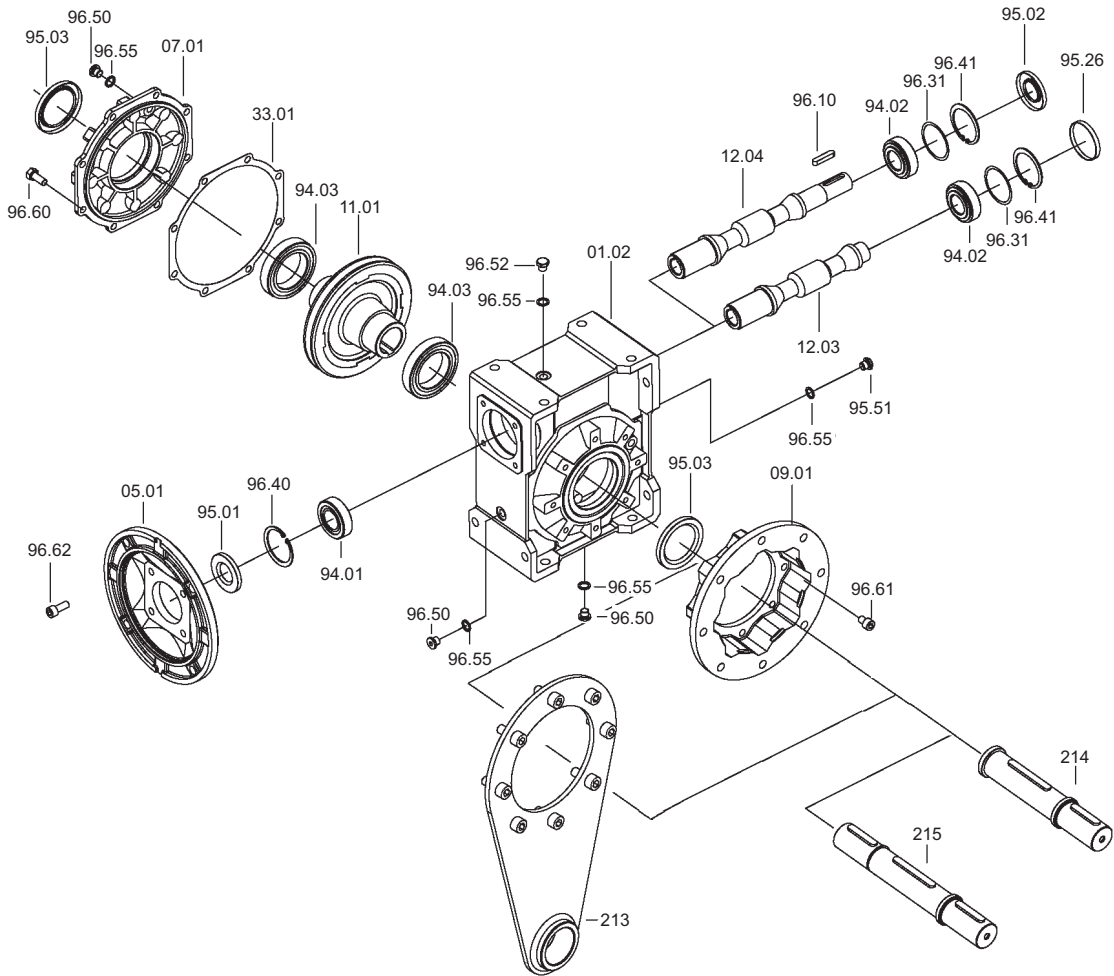

X	IEC	Cuscinetti / Bearings / Lager			Anelli di tenuta / Oilseals Öldichtungen			Cappellotto / Closed oil seal Geschlossene Öldichtung
		94.01	94.02	94.03	95.01	95.02	95.03	95.26
30	56	61804 (20x32x7)	6000 10x26x8	6005 25x47x12	20/32/7	10/26/7	25/40/7	ø 26x7
	63	61804 (20x32x7)			20/32/7			
40	56	6303 (17x47x14)	6201 12x32x10	6006 30x55x13	17/47/7	12/32/7	30/47/7	ø 32x7
	63	6204 (20x47x14)			20/47/7			
	71	6005 (25x47x12)			25/47/7			
50	63	6204 (20x47x14)	6203 17x40x12	6008 40x68x15	20/47/7	17/40/7	40/62/8	ø 40x7
	71	6005 (25x47x12)			25/47/7			
	80	6006 (30x55x13)			30/55/7			
63	71	30305 (25x62x18.25)	30204 20x47x15.25	6008 40x68x15	25/62/7	20/47/7	40/62/8	ø 47x7
	80	30206 (30x62x17.25)			30/62/7			
	90	32007 (35x62x18)			35/62/7			
75	80	30206 (30x62x17.25)	30205 25x52x16.25	6010 50x80x16	30/62/7	25/52/7	50/72/8	ø 52x7
	90	32007 (35x62x18)			35/62/7			
	100/112	32008 (40x68x19)			40/68/10			
90	80	30206 (30x62x17.25)	32205B 25x52x19.25	6010 50x80x16	30/62/7	25/52/7	50/72/8	ø 52x7
	90	32007 (35x62x18)			35/62/7			
	100/112	32008 (40x68x19)			40/68/10			
110	90	30208 (40x80x19.75)	32206B 30x62x21.25	6012 60x95x18	40/80/10	30/62/7	60/85/8	ø 62x7
	100/112	30208 (40x80x19.75)			40/80/10			
	132	32010 (50x80x20)			50/80/10			