



VEM  DRIVE

Permanent-magnet synchronous motors

Contents

Product description _____	12/2
Overview of technical data _____	12/4

Motor selection data

Series PE..	
for Super Premium Efficiency IE4 ¹⁾ _____	12/5
Series P..., high-power motors _____	12/7

Terminal boxes

Identical to terminal boxes of standard motors
see Chapter 2

Bearings

Identical to bearings of standard motors,
see Chapter 2

Dimensions

Identical to dimensions of standard motors
see Chapter 2 and assignment tables _____ 12/9

¹⁾ IE5 upon request (see VEMeKAT for latest status)

Product description

Permanent-magnet synchronous motors can be used wherever machines are to be driven with variable speed. As is the case for synchronous motors with separate excitation, a permanent-magnet synchronous motor also cannot be started directly on the mains. Permanent-magnet synchronous motors are intended solely for converter-fed operation. They represent a variant of standard motors, but are not to be considered replacements for servo drives.

As a permanent-magnet synchronous motor with field-oriented control displays similar characteristics to a DC machine, they were originally used almost exclusively for demanding variable-speed drive systems, as the elimination of brushes served to reduce maintenance costs.

Special notes regarding the calculation of a variable-speed drive system with permanent magnet synchronous motor

Permanent-magnet synchronous motors are excited by way of permanent magnets, i.e. the strength of the exciting field is determined when the machine is calculated and remains constant. There is thus no possibility for operation with field weakening in the classic manner known from asynchronous machines. Over the whole speed setting range (assumption: Rated speed = Maximum speed), the induced voltage is proportional to the speed.

If a correspondingly suitable converter is used, a limited field weakening range can be realised by modifying one component of the current.

The converter-fed operation of a permanent-magnet synchronous motor means that the standard assignment of a rated speed to a motor pole number and rated frequency (usually 50 Hz or 60 Hz) is no longer necessary. Optimum adaptation of the motor to the working machine or technological process, and similarly to the output voltage of the converter, is unproblematic.

A rated speed of 3000 rpm, for example, is realised with a 4-pole permanent-magnet synchronous motor with a 100 Hz winding. The product range does not include 2-pole permanent-magnet synchronous motors. On the other hand, lower rated speeds (e.g. 1200 or 900 rpm) can be realised with lower rated frequencies. Permanent-magnet synchronous motors can deliver very high overload torques, provided they

Nowadays, they are in increasingly widespread use in applications where maximum efficiency is the prime concern. The especially high efficiency in both full and partial load operation permits the realisation of economical drive solutions for working machines of all kinds.

Permanent-magnet synchronous motors meet the requirements of efficiency classifications IE3 and IE4 without additional expense for materials. The double savings effect of high efficiency in operation (reduced energy consumption) alongside reduced material input for manufacture (for the P21 series compared to an asynchronous motor with equivalent output) qualifies a drive with permanent-magnet synchronous motor as a sustainable investment in the future.

have been calculated accordingly and the converter is able to supply the necessary peak currents for the required duration.

As an option, permanent-magnet synchronous motors can also be supplied with position encoders. This enables precise determination of the speed of the magnet wheel and its position in the stator. In conjunction with field-oriented control, it is then possible to realise drives for applications which place very high demands on torque constancy and the accuracy of speed synchronisation, for example.

In case of high mass moments of inertia and fast speed changes, it may be necessary to use a brake resistor to protect the converter.

The motors can also be ordered as drive units with frequency converter. This brings the following benefits for the customer:

- Pre-parameterised unit
- Radio interference suppression to EN 55011, class A1, for shielded cable lengths up to 150 m
- Radio interference suppression to EN 55011, class B1, for shielded cable lengths up to 50 m
- Integrated brake chopper
- Mains input voltage 380 ...500 V \pm 10%, 50/60 Hz

Design versions

Series	Shaft height	Materials of housing, end shields and feet	Foot mounting
P.1R	63 bis 132 T	Grey cast iron	Bolted
PE2R	80 K4		Bolted
PE2R	71, 80 G4		Cast
P.1R	132 bis 280		Bolted
P2.R	315, 355		Cast
P20R	56 bis 80		Cast
P20R	90 bis 250		Bolted
P20R	280 bis 315		Cast

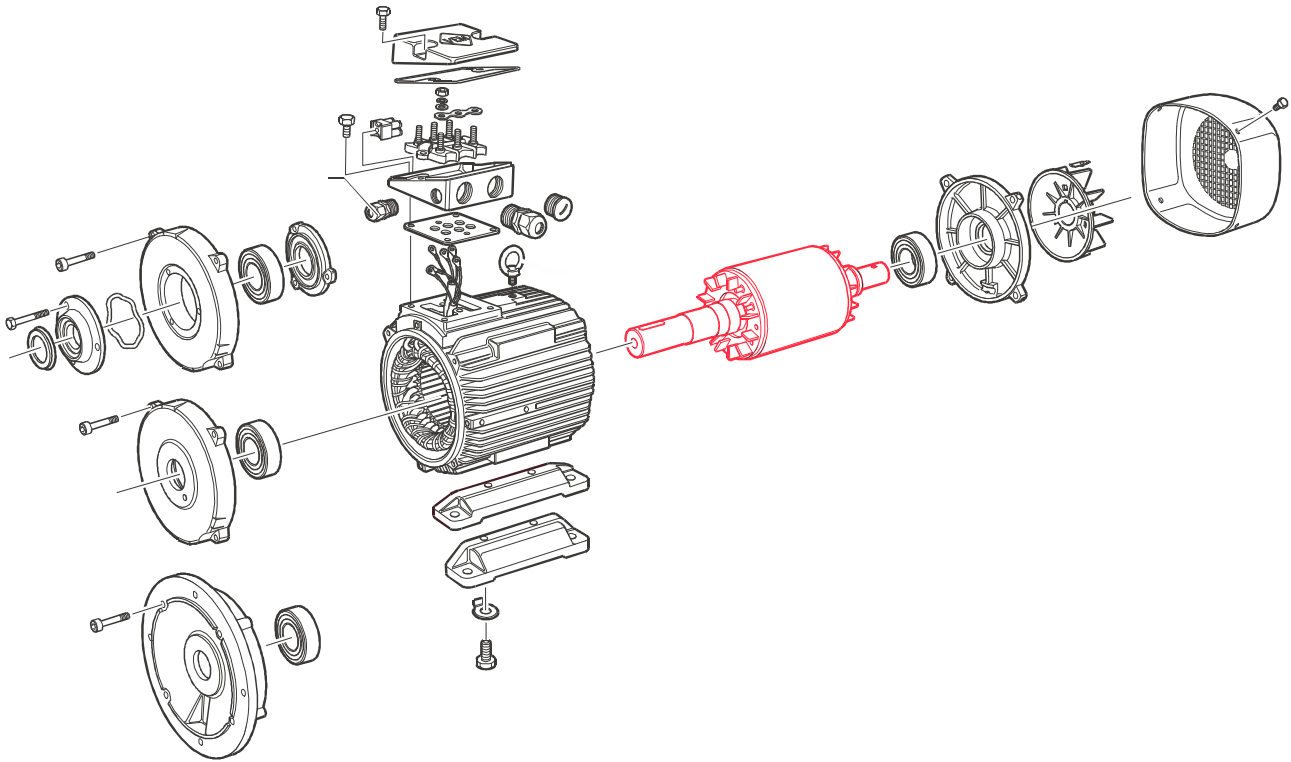

Fig. 1: Principle design of a PM motor

Outwardly, a permanent-magnet motor does not differ from an equivalent asynchronous motor. The design is based on that of the robust and reliable VEM standard motors in grey cast iron housing. The stator corresponds to the basic series K2.R, and the squirrel cage of an asynchronous

motor provides the basis for the magnet wheel (rotor). The squirrel-cage rotor body is turned after die-casting, neodymium iron boron magnets are glued around the body and the whole assembly is then bandaged (see photo below).



Fig. 2: PM rotor with magnets in place



Fig. 3: PM rotor complete with bandage

Overview of technical data

The most important technical data are summarised in the following table. Further information can be taken from the catalogue section "Technical explanations", chapter 1.

Product group	Magnetic rotor, IEC/EN
Rated output¹⁾	IE4-PE.R 63 bis 315, 0.12 to 250 kW P..R 63 bis 315, 0.12 bis 315 kW
Sizes	63 to 315
Housing material	Grey cast iron
Rated torque	0.8 Nm to 2000 Nm
Efficiency classification¹⁾/ efficiency determination	IEC DTS 60034-30-2 TS:2016 / IEC/TS 60034-2-3 Ed. 1.0: 2013
Method of connection	Single-speed motors are designed for star connection as standard.
Stator winding insulation	Thermal class 155 to IEC/EN 60034-1
Degree of protection	IP 55 to IEC/EN 60034-5
Type of cooling	IC 411, IC 416, IC 410, IC 418 IC 71W (IC 31W) upon request to EC/EN 60034-6
Coolant temperature/ installation altitude	Standard -20 °C to +40 °C, Altitude 1000 m above sea level
Rated voltage	Standard voltages to EN 60038 50 Hz: 230 V, 400 V, 500 V, 690 V 60 Hz: 275 V, 460 V, 480 V, 600 V
Duty Types	S1, continuous duty, Short-time duty S2, 10/30/60 min Duty Type S3/S6, 25/40/60 % c.d.f., S9
Types of construction	IM B3, IM B35, IM B5, IM B14, IM B34 and derived Types to IEC/EN 60034-7
Paint finish	Normal finish "Moderate", colour RAL 7031, blue-grey Special finish "Worldwide", colour RAL 7031, blue-grey
Vibration severity grade	Grade "A" as standard for machines with no special vibration requirements
Shaft ends	to DIN 748 (IEC 60072), balanced with half-key
Limit speeds	Please refer to the section of "Limit speeds" in catalogue section "Motors for converter-fed operation", Chapter 4.
Bearing design	Please refer to the tables of "Bearing design data" in catalogue section „Standand motors“, Chapter 2.
Motor mass	Please refer to the technical selection lists.
Terminal boxes	Please refer to the section "Terminal boxes" in catalogue section „Standand motors“, Chapter 2.
Documentation	An operating and maintenance manual, a terminal plan and a safety data sheet are supplied with each motor.
Tolerances	Please refer to the section "Tolerances" in catalogue section "Introduction", Chapter 1.
Options	Please refer to the section "Overview of modifications" in catalogue section "Introduction", Chapter 1.

¹⁾ IE5 upon request (see VEMeKAT for latest status)

Motor selection data

Permanent-magnet synchronous motors for converter-fed operation “Super Premium Efficiency IE4”¹⁾ according to IEC DTS 60034-30-2 TS 2016

with surface cooling, Type of cooling IC 411
Thermal class 155[F/B], degree of protection IP 55

Motor selection data											Converter input voltage 400 V, 50 Hz							
		Speed	Frequency	Rated output	Torque	Max. torque (2 min)	Voltage	Efficiency	Power factor	Rated current	Phase resistance at 20 °C	No-load voltage at 1000 rpm	Magnetising inductance	Leakage inductance	Magnetising reactance	Leakage reactance	Motor moment of inertia	Motor mass
		rpm	Hz	[kW]	[Nm]	[Nm]	[V]	100%	[-]	[A]	R _{1 20}	U _{P0 20}	L _{1H}	L _{1σ}	X _{1H}	X _{1σ}	J	m
Synchronous speed 3000 rpm – 4-pole version, rated frequency 100 Hz																		
IE4-PE1R 63 K4	IE4-PE0R 56 K4	3000	100	0.12	0.40	2.50	330	80	0.99	0.3	32	100	60	28	37.7	17.59	0.00019	4.8
IE4-PE1R 63 K4	IE4-PE0R 56 K4	3000	100	0.18	0.60	2.50	335	80	0.99	0.35	32	100	60	28	37.7	17.59	0.00019	4.8
IE4-PE1R 63 G4	IE4-PE0R 56 G4	3000	100	0.25	0.80	3.50	320	81.5	0.99	0.5	18	105	42	18	26.39	11.31	0.00024	5.2
IE4-PE1R 71 K4	IE4-PE0R 63 K4	3000	100	0.37	1.20	4.00	320	83.2	0.99	0.81	13.5	100	37	15	23.25	9.42	0.00040	6.8
IE4-PE1R 71 G4	IE4-PE0R 63 G4	3000	100	0.55	1.80	7.00	330	81.5	0.99	1.23	8.7	105	30	10	18.85	6.28	0.00050	7.8
IE4-PE1R 80 K4	IE4-PE0R 71 K4	3000	100	0.75	2.40	10.00	335	84.2	0.99	1.55	4.6	110	25	8	15.71	5.03	0.00087	10.6
IE4-PE1R 80 G4	IE4-PE0R 71 G4	3000	100	1.1	3.50	14.00	330	86.4	0.99	2.25	2.8	105	18	5	11.31	3.14	0.00107	11.7
IE4-PE1R 90 S4	IE4-PE0R 80 K4	3000	100	1.5	4.80	19.00	310	86.8	0.99	3.25	1.7	105	9.5	2.5	5.97	1.57	0.00207	15.5
IE4-PE1R 90 L4	IE4-PE0R 80 G4	3000	100	2.2	7.00	28.00	280	88.1	0.99	5.20	0.8	90	5	1	3.14	0.63	0.00260	18.0
IE4-PE1R 100 L4	IE4-PE0R 90 L4	3000	100	3.0	9.50	45.00	320	92.7	0.99	5.90	0.6	100	4.7	1.3	2.95	0.82	0.00400	23.5
IE4-PE1R 112 MY4	IE4-PE0R 100 S4	3000	100	4.0	12.70	50.00	330	91.2	0.99	7.75	0.4	110	3.2	0.8	2.01	0.50	0.00725	31.0
IE4-PE1R 132 SY4T	IE4-PE0R 100 L4	3000	100	5.5	17.50	85.00	310	92.3	1.00	11.10	0.25	110	2	0.5	1.26	0.31	0.009	39
IE4-PE1R 132 S4T	IE4-PE0R 100 LX4	3000	100	7.5	23.90	100.00	305	92.8	1.00	15.30	0.2	105	1.2	0.3	0.75	0.19	0.011	47
IE4-PE1R 132 M4	IE4-PE0R 132 S4	3000	100	11.0	35.00	44.00	344	92.6	1.00	20.0	0.1170	121	2.280	0.960	1.432	0.603	0.022	72
IE4-PE1R 132 M4	IE4-PE0R 132 S4	3000	100	15.0	48.00	60.00	347	93.4	1.00	26.7	0.1170	121	2.280	0.960	1.432	0.603	0.022	72
IE4-PE1R 160 M4	IE4-PE0R 132 M4	3000	100	18.5	59.00	74.00	350	93.8	1.00	32.6	0.0690	116	1.660	0.630	1.042	0.396	0.031	92
IE4-PE1R 160 L4	IE4-PE0R 160 S4	3000	100	18.5	59.00	74.00	372	93.9	0.99	31.0	0.0480	121	1.576	0.526	0.990	0.330	0.062	121
IE4-PE1R 180 M4	IE4-PE0R 160 M4	3000	100	22.0	70.00	88.00	346	94.0	1.00	39.0	0.0410	123	1.350	0.460	0.848	0.289	0.079	135
IE4-PE1R 180 M4	IE4-PE0R 160 M4	3000	100	30.0	96.00	120.00	347	94.5	0.99	53.5	0.0410	123	1.350	0.460	0.848	0.289	0.079	135
IE4-PE1R 180 L4	IE4-PE0R 180 S4	3000	100	30.0	96.00	119.00	362	94.7	0.98	52.0	0.0270	116	1.150	0.360	0.722	0.226	0.116	170
IE4-PE1R 200 L4	IE4-PE0R 180 M4	3000	100	37.0	118.00	147.00	365	95	0.98	63.0	0.0180	118	0.901	0.257	0.566	0.161	0.150	200
IE4-PE1R 225 S4	IE4-PE0R 200 M4	3000	100	45.0	143.00	179.00	365	95.1	0.98	76.5	0.0110	118	0.725	0.198	0.455	0.124	0.251	270
IE4-PE1R 225 M4	IE4-PE0R 200 L4	3000	100	55.0	175.00	218.00	355	95.4	0.98	96.0	0.0091	115	0.587	0.153	0.369	0.096	0.288	300
IE4-PE1R 250 M4	IE4-PE0R 225 M4	3000	100	75.0	239.00	298.00	369	95.7	0.97	127.0	0.0073	118	0.543	0.144	0.341	0.090	0.457	375
IE4-PE1R 250 M4	IE4-PE0R 225 M4	3000	100	90.0	287.00	358.00	374	96	0.96	151.0	0.0073	118	0.543	0.145	0.341	0.091	0.457	375
IE4-PE1R 280 S4	IE4-PE0R 250 S4	3000	100	110.0	350.00	438.00	363	96.1	0.96	190.0	0.0045	115	0.420	0.111	0.264	0.070	0.864	520
IE4-PE1R 280 S4	IE4-PE0R 250 S4	3000	100	132.0	420.00	525.00	370	96.4	0.94	228.0	0.0045	115	0.420	0.111	0.264	0.070	0.864	520
IE4-PE1R 280 M4	IE4-PE0R 250 M4	3000	100	160.0	509.00	637.00	380	96.5	0.94	269.0	0.0037	118	0.373	0.085	0.234	0.053	1.011	580
IE4-PE1R 315 MX4	IE4-PE0R 315 S4	3000	100	200.0	637.00	796.00	360	96.9	0.98	339.0	0.0019	117	0.152	0.038	0.095	0.024	1.556	980
IE4-PE1R 315 MY4	IE4-PE0R 315 M4	3000	100	250.0	796.00	995.00	380	97.1	0.97	406.0	0.0018	123	0.161	0.036	0.101	0.023	2.499	1170

¹⁾ IE5 upon request (see VEMeKAT for latest status)

**Permanent-magnet synchronous motors for converter-fed operation
“Super Premium Efficiency IE4”¹⁾ according to IEC DTS 60034-30-2 TS 2016**

with surface cooling, Type of cooling IC 411
Thermal class 155[F/B], degree of protection IP 55

Motor selection data												Converter input voltage 400 V, 50 Hz									
		Speed	Frequency	Rated output	Torque	Max torque (2 min)	Voltage	Efficiency	Power factor	Rated current	Phase resistance at 20 °C	No-load voltage at 1000 rpm	Magnetising inductance	Leakage inductance	Magnetising reactance	Leakage reactance	Motor moment of inertia	Motor mass			
		rpm	Hz	[kW]	[Nm]	[Nm]	[V]	100%	[-]	[A]	R _{1 20} [Ω]	U _{p0 20} [V/1000 rpm]	L _{1H} [mH]	L _{1σ} [mH]	X _{1H} [Ω]	X _{1σ} [Ω]	J kgm ²	m kg			
Synchronous speed 1500 rpm – 4-pole version, rated frequency 50 Hz																					
IE4-PE1R 63 K4	IE4-PE0R 56 K4	1500	50	0.12	0.8	2.5	310	76.0	0.98	0.3	95	170	160	80	50.3	25.13	0.00019	4.8			
IE4-PE1R 63 G4	IE4-PE0R 56 G4	1500	50	0.18	1.1	3.5	310	80.5	0.98	0.41	57	180	130	60	40.8	18.85	0.00024	5.2			
IE4-PE2R 71 K4	IE4-PE0R 71 K4	1500	50	0.25	1.6	10	290	84.4	1.00	0.65	14.5	190	76	24	23.9	7.54	0.00087	9.9			
IE4-PE2R 71 G4	IE4-PE0R 71 G4	1500	50	0.37	2.4	14	290	90.7	0.99	0.82	9.5	195	61	19	19.2	5.97	0.00107	11.0			
IE4-PE2R 80 K4	IE4-PE0R 71 G4	1500	50	0.55	3.5	14	300	87.6	0.99	1.22	9.5	195	61	19	19.2	5.97	0.00107	11.7			
IE4-PE2R 80 G4	IE4-PE0R 80 K4	1500	50	0.75	4.8	19	305	87.5	0.99	1.60	6	195	36	9	11.3	2.83	0.00207	14.5			
IE4-PE2R 90 S4	IE4-PE0R 80 G4	1500	50	1.1	7	28	300	91.5	0.99	2.35	3.4	190	24.5	5.5	7.7	1.73	0.00260	18.0			
IE4-PE1R 90 L4	IE4-PE0R 80 G4	1500	50	1.5	9.5	28	305	88.3	0.99	3.25	3.4	190	24.5	5.5	7.7	1.73	0.00260	18.0			
IE4-PE1R 100 L4	IE4-PE0R 90 L4	1500	50	2.2	14	45	315	90.5	0.99	4.5	2.1	195	15.5	4.5	4.9	1.41	0.00400	23.5			
IE4-PE1R 100 LX4	IE4-PE0R 100 S4	1500	50	3.0	19.1	50	335	91.6	0.99	5.7	1.5	215	16.0	4.0	5.0	1.26	0.00725	30.0			
IE4-PE1R 112 M4	IE4-PE0R 100 L4	1500	50	4.0	25.5	70	320	92.3	0.99	7.9	0.9	205	10.5	2.5	3.3	0.79	0.009	37.0			
IE4-PE1R 112 MX4	IE4-PE0R 100 LX4	1500	50	5.5	35	100	325	93.1	0.99	10.6	0.65	210	8.2	1.8	2.6	0.57	0.011	45.0			
IE4-PE1R 132 M4	IE4-PE0R 132 S4	1500	50	7.5	48.00	60.00	362	93.5	0.99	13.0	0.4290	232	8.379	3.486	2.631	1.095	0.022	70			
IE4-PE1R 160 M4	IE4-PE0R 132 M4	1500	50	11.0	70.00	88.00	362	94.1	0.99	19.0	0.2510	235	5.847	2.227	1.836	0.699	0.031	92			
IE4-PE1R 160 L4	IE4-PE0R 160 S4	1500	50	15.0	96.00	119.00	357	94.3	0.98	26.5	0.1250	229	3.717	1.306	1.167	0.410	0.068	120			
IE4-PE1R 180 M4	IE4-PE0R 160 M4	1500	50	18.5	118.00	147.00	364	94.8	0.98	32.0	0.1340	233	5.101	1.613	1.602	0.506	0.073	136			
IE4-PE1R 180 L4	IE4-PE0R 180 S4	1500	50	22.0	140.00	175.00	354	95	0.98	39.0	0.0720	226	2.840	0.937	0.892	0.294	0.126	170			
IE4-PE1R 200 L4	IE4-PE0R 180 M4	1500	50	30.0	191.00	239.00	360	95.3	0.98	52.0	0.0510	230	2.210	0.675	0.694	0.212	0.162	220			
IE4-PE1R 225 S4	IE4-PE0R 200 M4	1500	50	37.0	236.00	294.00	355	95.5	0.97	65.0	0.0290	228	1.800	0.531	0.565	0.167	0.269	270			
IE4-PE1R 225 M4	IE4-PE0R 200 L4	1500	50	45.0	287.00	358.00	363	95.7	0.98	77.0	0.0240	233	1.603	0.450	0.503	0.141	0.308	300			
IE4-PE1R 250 M4	IE4-PE0R 225 M4	1500	50	55.0	350.00	438.00	355	95.8	0.97	96.0	0.0170	228	1.231	0.347	0.387	0.109	0.492	375			
IE4-PE1R 250 M4	IE4-PE0R 225 M4	1500	50	75.0	478.00	597.00	366	96.1	0.98	126.0	0.0170	237	1.319	0.369	0.414	0.116	0.492	375			
IE4-PE1R 280 S4	IE4-PE0R 250 S4	1500	50	90.0	573.00	716.00	369	96.3	0.98	150.0	0.0120	239	1.176	0.283	0.369	0.089	0.911	520			
IE4-PE1R 280 M4	IE4-PE0R 250 M4	1500	50	110.0	700.00	875.00	359	96.4	0.96	191.0	0.0088	229	0.897	0.207	0.282	0.065	1.065	580			
IE4-PE1R 280 M4	IE4-PE0R 250 M4	1500	50	132.0	840.00	1050.00	373	96.5	0.98	216.0	0.0099	243	0.848	0.250	0.266	0.079	1.089	580			
IE4-PE1R 315 S4	IE4-PE0R 280 S4	1500	50	160.0	1019.00	1273.00	356	96.8	0.95	283.0	0.0060	224	0.727	0.155	0.228	0.049	1.750	740			
IE4-PE1R 315 MX4	IE4-PE0R 315 S4	1500	50	200.0	1273.00	1592.00	366	96.9	0.98	333.0	0.0044	239	0.484	0.114	0.152	0.036	2.350	1000			
IE4-PE1R 315 MY4	IE4-PE0R 315 M4	1500	50	250.0	1592.00	1990.00	372	97	0.96	418.0	0.0035	236	0.389	0.078	0.122	0.024	4.224	1200			
Synchronous speed 1000 rpm – 6-pole version, rated frequency 50 Hz																					
IE4-PE1R 132 MX6	IE4-PE0R 132 S6	1000	50	5.5	53.00	66.00	362	91.5	0.99	10.0	0.5350	348	6.624	3.072	2.080	0.965	0.040	70			
IE4-PE1R 160 M6	IE4-PE0R 132 M6	1000	50	7.5	72.00	90.00	364	91.7	0.99	13.0	0.3580	351	5.160	2.300	1.620	0.722	0.052	86			
IE4-PE1R 160 L6	IE4-PE0R 160 S6	1000	50	11.0	105.00	131.00	361	92.5	0.98	19.5	0.2390	345	4.549	1.729	1.428	0.543	0.104	114			
IE4-PE1R 180 L6	IE4-PE0R 160 M6	1000	50	15.0	143.00	179.00	360	93.1	0.98	26.5	0.1590	345	3.385	1.217	1.063	0.382	0.135	136			
IE4-PE1R 180 L6	IE4-PE0R 160 M6	1000	50	18.5	177.00	221.00	358	93.6	0.99	32.5	0.1545	347	3.403	1.217	1.069	0.382	0.135	136			
IE4-PE1R 200 L6	IE4-PE0R 180 S6	1000	50	22.0	210.00	263.00	359	93.9	0.99	38.0	0.1140	355	3.332	1.136	1.046	0.357	0.219	175			
IE4-PE1R 200 LX6	IE4-PE0R 180 M6	1000	50	30.0	287.00	358.00	359	94.3	0.98	52.5	0.0790	343	2.538	0.835	0.797	0.262	0.270	200			
IE4-PE1R 225 M6	IE4-PE0R 200 M6	1000	50	37.0	353.00	442.00	362	94.6	0.981	64.0	0.0495	350	1.899	0.610	0.596	0.192	0.437	265			
IE4-PE1R 250 M6	IE4-PE0R 225 M6	1000	50	45.0	430.00	537.00	360	94.9	0.98	78.0	0.0375	349	1.604	0.529	0.504	0.166	0.711	360			
IE4-PE1R 280 S6	IE4-PE0R 250 S6	1000	50	55.0	525.00	657.00	360	95.3	0.95	98.0	0.0335	334	1.656	0.538	0.520	0.169	1.142	465			
IE4-PE1R 280 M6	IE4-PE0R 250 M6	1000	50	75.0	716.00	895.00	367	95.5	0.97	128.0	0.0260	348	1.414	0.436	0.444	0.137	1.423	520			
IE4-PE1R 315 S6	IE4-PE0R 280 S6	1000	50	90.0	860.00	1074.00	358	95.8	0.95	160.0	0.0163	334	1.123	0.348	0.353	0.109	2.275	690			
IE4-PE1R 315 M6	IE4-PE0R 280 M6	1000	50	110.0	1050.00	1313.00	360	96	0.96	192.0	0.0120	341	0.908	0.266	0.285	0.084	2.875	800			
IE4-PE1R 315 MX6	IE4-PE0R 315 S6	1000	50	132.0	1261.00	1576.00	371	96.2	0.97	221.0	0.0116	356	0.910	0.262	0.286	0.082	3.110	890			
IE4-PE1R 315 MY6	IE4-PE0R 315 M6	1000	50	160.0	1528.00	1910.00	368	96.3	0.97	269.0	0.0076	353	0.717	0.181	0.225	0.057	5.285	1050			
IE4-PE1R 315 L6	IE4-PE0R 315 L6	1000	50	200.0	1273.00	1592.00	365	96.4	0.96	342.0	0.0063	347	0.612	0.151	0.192	0.047	5.940	1250			
IE4-PE1R 315 LX6	IE4-PE0R 315 LX6	1000	50	250.0	1592.00	1990.00	362	96.5	0.95	435.0	0.0043	340	0.451	0.106	0.142	0.033	7.644	1460			

Permanent-magnet synchronous motors for converter-fed operation Series P2.R, high-power motors

Increased output, with surface cooling, Type of cooling IC 411
Thermal class 155[F/B], degree of protection IP 55

Motor selection data												Converter input voltage 400 V, 50 Hz							
		Speed	Frequency	Rated output	Torque	Max. torque (2 min)	Voltage	Efficiency	Power factor	Rated current	Phase resistance at 20 °C	No-load voltage at 1000 rpm	Magnetising inductance	Leakage inductance	Magnetising reactance	Leakage reactance	Motor moment of inertia	Motor mass	
		rpm	Hz	[kW]	[Nm]	[Nm]	[V]	100%	[-]	[A]	R _{1 20} [Ω]	U _{P0 20} [V/1000 rpm]	L _{1H} [mH]	L _{1σ} [mH]	X _{1H} [Ω]	X _{1σ} [Ω]	J kgm ²	m kg	
Synchronous speed 3000 rpm – 4-pole version, rated frequency 100 Hz																			
P21R 63 K4	P20R 56 K4	3000	100	0.37	1.2	2.5	330	77.5	0.98	0.80	26	95	50	20	31.4	12.6	0.00019	4.8	
P21R 63 G4	P20R 56 G4	3000	100	0.55	1.8	3.5	334	78	0.98	1.20	17	100	35	15	22.0	9.4	0.00024	5.2	
P21R 71 K4	P20R 63 K4	3000	100	0.75	2.4	4	330	77.0	0.98	1.74	11.5	100	30	13	18.8	8.2	0.00040	6.8	
P21R 71 G4	P20R 63 G4	3000	100	1.10	3.5	7	320	78.0	0.98	2.50	7.5	93	25	10	15.7	6.3	0.00050	7.8	
P21R 80 K4	P20R 71 K4	3000	100	1.50	4.8	10	320	81.0	0.98	3.20	4.5	100	21	6	13.2	3.8	0.00087	10.6	
P21R 80 G4	P20R 71 G4	3000	100	2.2	7.0	14	310	90.0	0.96	4.70	2.4	100	15	5	9.4	3.1	0.00107	11.7	
P21R 90 S4	P20R 80 K4	3000	100	3.0	9.5	19	325	86.3	0.98	6.30	1.7	105	9.5	2.5	6.0	1.6	0.00207	15.5	
P21R 90 L4	P20R 80 G4	3000	100	4.0	12.7	28	290	87.4	0.98	9.30	0.8	90	5	1	3.1	0.6	0.00260	18.0	
P21R 100 L4	P20R 90 L4	3000	100	5.5	17.5	45	320	92.9	0.98	10.90	0.6	100	4.7	1.3	3.0	0.8	0.00400	23.5	
P21R 112 MY4	P20R 100 S4	3000	100	7.5	23.9	50	330	93.3	0.99	14.20	0.4	110	3.2	0.8	2.0	0.5	0.00725	31.0	
P21R 132 M4	P20R 132 S4	3000	100	15	48	60.0	357	90.3	0.99	27.1	0.1	117	1.682	0.738	1.056	0.463	0.024	72	
P21R 160 M4	P20R 132 M4	3000	100	18.5	59.0	74.0	366	90.9	0.99	32.4	0.059	120	1.207	0.485	0.758	0.305	0.033	92	
P21R 160 L4	P20R 160 S4	3000	100	22	70.0	88.0	362	91.3	0.99	38.8	0.037	119	1.187	0.398	0.745	0.25	0.065	120	
P21R 180 M4	P20R 160 M4	3000	100	30	96.0	120.0	358	92	0.99	53.0	0.032	117	1.003	0.327	0.63	0.205	0.076	135	
P21R 180 L4	P20R 180 S4	3000	100	37	118.0	148.0	367	92.5	0.99	64.0	0.021	121	0.811	0.267	0.509	0.168	0.126	170	
P21R 200 L4	P20R 180 M4	3000	100	45	143.0	179.0	359	92.9	0.99	79.0	0.0138	118	0.577	0.176	0.362	0.111	0.162	200	
P21R 225 S4	P20R 200 M4	3000	100	55	175.0	219.0	358	93.2	1	95.0	0.00865	119	0.536	0.153	0.337	0.096	0.264	270	
P21R 225 M4	P20R 200 L4	3000	100	75	239.0	299.0	362	93.8	0.99	129.0	0.0073	119	0.457	0.125	0.287	0.0785	0.303	300	
P21R 250 M4	P20R 225 M4	3000	100	90	287.0	359.0	363	94.1	1	152.0	0.0053	121	0.378	0.104	0.237	0.0653	0.485	375	
P21R 280 S4	P20R 250 S4	3000	100	110	350.0	438.0	371	94.3	1	182.0	0.0035	124	0.317	0.076	0.199	0.0477	0.911	520	
P21R 280 M4	P20R 250 M4	3000	100	132	420.0	525.0	373	94.6	1	216.0	0.0029	126	0.269	0.063	0.169	0.0396	1.065	580	
P21R 315 S4	P20R 280 S4	3000	100	160	509.0	636.0	371	94.8	1	263.0	0.00623	124	0.672	0.14	0.422	0.0879	1.75	740	
P21R 315 M4	P20R 280 M4	3000	100	200	637.0	796.0	365	95	1	333.0	0.0046	121	0.546	0.108	0.343	0.0678	1.75	840	
Synchronous speed 1500 rpm – 4-pole version, rated frequency 50 Hz																			
P21R 63 K4	P20R 56 K4	1500	50	0.18	1.1	2.5	340	73.0	0.98	0.45	95	170	160	80	50.3	25.1	0.00019	4.8	
P21R 63 G4	P20R 56 G4	1500	50	0.25	1.6	3.5	330	77.5	0.98	0.57	57	180	130	60	40.8	18.9	0.00024	5.2	
P21R 71 K4	P20R 63 K4	1500	50	0.3	1.9	4.0	315	66.5	0.98	0.75	44	165	110	50	34.6	15.7	0.0004	6.8	
P21R 71 G4	P20R 63 G4	1500	50	0.5	3.2	7.0	340	75.0	0.98	1.40	27	175	85	35	26.7	11.0	0.00050	7.8	
P21R 80 K4	P20R 71 K4	1500	50	0.75	4.8	10.0	325	80.6	0.99	1.75	14.5	190	76	24	23.9	7.5	0.00087	10.6	
P21R 80 G4	P20R 71 G4	1500	50	1.1	7.0	14.0	330	82.7	0.99	2.35	9.5	195	61	19	19.2	6.0	0.00107	11.7	
P21R 90 S4	P20R 80 K4	1500	50	1.5	9.5	19.0	330	81.1	0.98	3.30	6	195	36	9	11.3	2.8	0.00207	15.5	
P21R 90 L4	P20R 80 G4	1500	50	2.2	14.0	28.0	320	85.3	0.97	4.80	3.4	190	24.5	5.5	7.7	1.7	0.00260	18.0	
P21R 100 L4	P20R 90 L4	1500	50	3	325.0	45.0	325	87.7	0.98	6.20	2.1	195	15.5	4.5	4.9	1.4	0.00400	23.5	
P21R 100 LX4	P20R 100 S4	1500	50	4	25.5	50.0	320	89.1	0.97	8.35	1.4	200	16.0	4.0	5.0	1.3	0.00725	30.0	
P21R 112 M4	P20R 100 L4	1500	50	5.5	35.0	85.0	325	91.5	0.98	10.90	0.9	205	10.5	2.5	3.3	0.8	0.009	37.0	
P21R 132 S4T	P20R 100 LX4	1500	50	7.5	47.7	100.0	330	91.7	0.98	14.60	0.65	210	8.2	1.8	2.6	0.6	0.011	47.0	
P21R 132 M4	P20R 132 S4	1500	50	11	70.0	88.0	361	89.8	0.99	19.8	0.359	230	6.59	2.85	2.069	0.895	0.024	70	
P21R 160 M4	P20R 132 M4	1500	50	15	96.0	120	364	90.6	0.99	26.5	0.204	236	4.63	1.85	1.454	0.581	0.033	92	
P21R 160 L4	P20R 160 S4	1500	50	18.5	118	148	363	91.2	0.99	32.6	0.125	236	3.90	1.37	1.225	0.43	0.068	120	
P21R 180 M4	P20R 160 M4	1500	50	22	140	175	363	91.6	0.99	38.6	0.096	236	3.27	0.99	1.027	0.311	0.079	136	
P21R 180 L4	P20R 180 S4	1500	50	30	191	239	362	92.3	0.98	53.0	0.0742	233	2.98	0.969	0.934	0.304	0.126	170	
P21R 200 L4	P20R 180 M4	1500	50	37	236	295	363	92.7	0.99	64.0	0.05	236	2.35	0.704	0.736	0.221	0.162	200	
P21R 225 S4	P20R 200 M4	1500	50	45	287	359	361	93.1	0.99	78.0	0.029	239	1.94	0.558	0.61	0.175	0.269	270	
P21R 225 M4	P20R 200 L4	1500	50	55	350	438	356	93.5	0.99	96.0	0.024	234	1.63	0.45	0.513	0.141	0.308	300	
P21R 250 M4	P20R 225 M4	1500	50	75	478	598	363	94	0.99	128.0	0.0173	238	1.33	0.37	0.416	0.116	0.492	380	
P21R 280 S4	P20R 250 S4	1500	50	90	573	716	359	94.2	0.99	155.0	0.0106	237	1.00	0.242	0.315	0.076	0.935	535	
P21R 280 M4	P20R 250 M4	1500	50	110	700	875	360	94.5	0.99	189.0	0.00825	238	0.82	0.189	0.257	0.0593	1.089	600	
P21R 315 S4	P20R 280S 4	1500	50	132	840	1050	362	94.7	0.99	225.0	0.00628	241	0.72	0.155	0.226	0.0487	1.79	740	
P21R 315 S4	P20R 280M 4	1500	50	160	1019	1274	363	94.9	0.99	271.0	0.00509	239	0.59	0.1223	0.186	0.0384	2.071	840	
P21R 315 MX4	P20R 315 S4	1500	50	200	1273	1591	361	95.1	0.99	340.0	0.00384	238	0.42	0.0994	0.131	0.0312	2.406	1000	
P21R 315 MY4	P20R 315 M4	1500	50	250	1592	1990	361	95.1	0.99	425.0	0.00359	237	0.39	0.0776	0.122	0.0244	4.224	1200	
P21R 315 L4	P20R 315 L4	1500	50	315	2006	2508	619	95.1	0.99	312.0	0.00763	409	0.91	0.171	0.284	0.0537	5.273	1450	

**Permanent-magnet synchronous motors for converter-fed operation
Series P2.R, high-power motors**

Increased output, with surface cooling, Type of cooling IC 411
Thermal class 155[F/B], degree of protection IP 55

Motor selection data												Converter input voltage 400 V, 50 Hz							
		Speed	Frequency	Rated output	Torque	Max. torque (2 min)	Voltage	Efficiency	Power factor	Rated current	Phase resistance at 20 °C	No-load voltage at 1000 rpm	Magnetising inductance	Leakage inductance	Magnetising reactance	Leakage reactance	Motor moment of inertia	Motor mass	
		rpm	Hz	[kW]	[Nm]	[Nm]	[V]	100%	[-]	[A]	R _{1 20} [Ω]	U _{P0 20} [V/1000 rpm]	L _{1H} [mH]	L _{1σ} [mH]	X _{1H} [Ω]	X _{1σ} [Ω]	J kgm ²	m kg	
Synchronous speed 1000 rpm – 6-pole version, rated frequency 50 Hz																			
P21R 132 M6	P20R 112 MX6	1000	50	5.5	53	66	353	86.5	1	10.4	0.991	344	7.75	4.02	2.434	1.262	0.021	53	
P21R 132 MX6	P20R 132 S6	1000	50	7.5	72	90	362	88.5	0.99	13.7	0.501	348	6.64	3.072	2.084	0.965	0.04	70	
P21R 160 M6	P20R 132 M6	1000	50	11	105	131	359	90.2	0.99	19.8	0.348	342	4.69	2.177	1.472	0.684	0.052	86	
P21R 160 L6	P20R 160 S6	1000	50	15	143	179	360	91	1	26.4	0.252	356	4.76	1.796	1.494	0.564	0.103	114	
P21R 180 L6	P20R 160 M6	1000	50	18.5	177	221	360	91.5	0.99	32.8	0.168	347	3.40	1.217	1.067	0.382	0.135	136	
P21R 200 L6	P20R 180 S6	1000	50	22	210	263	354	92	1	39.0	0.103	347	3.00	1.026	0.942	0.322	0.223	175	
P21R 200 LX6	P20R 180 M6	1000	50	30	287	359	359	92.7	0.99	53.0	0.077	351	2.33	0.784	0.733	0.246	0.27	200	
P21R 225 M6	P20R 200 M6	1000	50	37	353	441	361	93.1	0.99	64.0	0.054	352	1.92	0.61	0.602	0.192	0.437	265	
P21R 250 M6	P20R 225 M6	1000	50	45	430	538	360	93.5	0.99	78.0	0.038	351	1.45	0.49	0.455	0.154	0.721	360	
P21R 280 S6	P20R 250 S6	1000	50	55	525	656	362	93.9	1	93.0	0.026	360	1.25	0.412	0.394	0.129	1.198	465	
P21R 280 M6	P20R 250 M6	1000	50	75	716	895	362	94.1	0.99	128.0	0.0204	357	0.95	0.297	0.297	0.0933	1.492	520	
P21R 315 S6	P20R 280 S6	1000	50	90	860	1075	359	94.3	0.99	155.0	0.014	353	0.99	0.29	0.311	0.0911	2.367	690	
P21R 315 M6	P20R 280 M6	1000	50	110	1051	1314	363	94.9	0.99	186.0	0.0119	362	0.81	0.23	0.255	0.0722	2.981	800	
P21R 315 MX6	P20R 315 S6	1000	50	132	1261	1576	358	95.2	0.98	228.0	0.0086	350	0.70	0.192	0.22	0.0603	3.226	880	
P21R 315 MY6	P20R 315 M6	1000	50	160	1528	1910	362	95.4	0.98	273.0	0.00759	358	0.69	0.181	0.216	0.0568	5.334	1050	
P21R 315 L6	P20R 315 L6	1000	50	200	1910	2388	361	95.6	0.97	345.0	0.0058	347	0.55	0.137	0.173	0.043	5.995	1250	
P21R 315 LX6	P20R 315 LX6	1000	50	250	2388	2985	363	95.6	0.99	420.0	0.0043	359	0.45	0.106	0.142	0.0333	7.714	1450	
Synchronous speed 750 rpm – 8-pole version, rated frequency 50 Hz																			
P21R 160 M8	P20R 132 S8	750	50	5.5	70	88	358	84.6	0.99	10.6	0.747	452	5.30	4.223	1.665	1.326	0.042	70	
P21R 160 MX8	P20R 132 M8	750	50	7.5	96	120	361	86.5	0.99	14.0	0.515	459	4.15	3.231	1.302	1.015	0.054	86	
P21R 160 L8	P20R 160 S8	750	50	11	140	175	362	87.5	0.99	20.3	0.326	459	4.77	2.11	1.499	0.663	0.106	114	
P21R 180 L8	P20R 160 M8	750	50	15	191	239	358	88.7	0.99	27.5	0.381	446	3.07	2.68	0.964	0.842	0.138	136	
P21R 200 L8	P20R 180 S8	750	50	18.5	236	295												175	
P21R 200 LX8	P20R 180 M8	750	50	22	280	350												200	
P21R 225 M8	P20R 200 M8	750	50	30	382	478	360	90.5	0.98	54.0	0.0815	459	1.83	0.897	0.576	0.282	0.439	265	
P21R 250 M8	P20R 225 M8	750	50	37	471	589												360	

Terminal boxes, bearings and dimensions

The permanent-magnet synchronous motors IE4-PE.R are identical to the series K21R/WE.R.
For further information regarding the terminal boxes, bearings and dimensions, please refer to Chapter 2.

Assignment table					
Type		Type	Type	J	m
PE.R		K21R	K20R	kgm ²	kg
Synchronous speed 3000 rpm – 4-pole version, rated frequency 100 Hz					
IE4-PE1R 63 K4	IE4-PE0R 56 K4	K21R 63 K2	K20R 56 K2	0.00019	4.8
IE4-PE1R 63 G4	IE4-PE0R 56 G4	K21R 63 G2	K20R 56 G2	0.00019	4.8
IE4-PE1R 63 G4	IE4-PE0R 56 G4	K21R 63 G2	K20R 56 G2	0.00024	5.2
IE4-PE1R 71 K4	IE4-PE0R 63 K4	K21R 71 K2	K20R 63 K2	0.00040	6.8
IE4-PE1R 71 G4	IE4-PE0R 63 G4	K21R 71 G2	K20R 63 G2	0.00050	7.8
IE4-PE1R 80 K4	IE4-PE0R 71 K4	K21R 80 K2	K20R 71 K2	0.00087	10.6
IE4-PE1R 80 G4	IE4-PE0R 71 G4	K21R 80 G2	K20R 71 G2	0.00107	11.7
IE4-PE1R 90 S4	IE4-PE0R 80 K4	K21R 90 S2	K20R 80 K2	0.00207	15.5
IE4-PE1R 90 L4	IE4-PE0R 80 G4	K21R 90 L2	K20R 80 G2	0.00260	18.0
IE4-PE1R 100 L4	IE4-PE0R 90 L4	K21R 100 L2	K20R 90 L2	0.00400	23.5
IE4-PE1R 112 MY4	IE4-PE0R 100 S4	K21R 112 M2	K20R 100 S2	0.00725	31.0
IE4-PE1R 132 SY4T	IE4-PE0R 100 L4	K21R 132 ST	K20R 100 L2	0.0090	39.0
IE4-PE1R 132 S4T	IE4-PE0R 100 LX4	K21R 132 SX2T	K20R 100 LX2	0.0110	47.0
IE4-PE1R 132 M4	IE4-PE0R 132 S4	K21R 132 M4	K20R 132 S4	0.022	72
IE4-PE1R 132 M4	IE4-PE0R 132 S4	K21R 132 M4	K20R 132 S4	0.022	72
IE4-PE1R 160 M4	IE4-PE0R 132 M4	K21R 160 M4	K20R 132 M4	0.031	92
IE4-PE1R 160 L4	IE4-PE0R 160 S4	K21R 160 L4	K20R 160 S4	0.062	121
IE4-PE1R 180 M4	IE4-PE0R 160 M4	K21R 180 M4	K20R 160 M4	0.079	135
IE4-PE1R 180 M4	IE4-PE0R 160 M4	K21R 180 M4	K20R 160 M4	0.079	135
IE4-PE1R 180 L4	IE4-PE0R 180 S4	K21R 180 L4	K20R 180 S4	0.116	170
IE4-PE1R 200 L4	IE4-PE0R 180 M4	K21R 200 L4	K20R 180 M4	0.150	200
IE4-PE1R 225 S4	IE4-PE0R 200 M4	K21R 225 S4	K20R 200 M4	0.251	270
IE4-PE1R 225 M4	IE4-PE0R 200 L4	K21R 225 M4	K20R 200 L4	0.288	300
IE4-PE1R 250 M4	IE4-PE0R 225 M4	K21R 250 M4	K20R 225 M4	0.457	375
IE4-PE1R 250 M4	IE4-PE0R 225 M4	K21R 250 M4	K20R 225 M4	0.457	375
IE4-PE1R 280 S4	IE4-PE0R 250 S4	K21R 280 S4	K20R 250 S4	0.864	520
IE4-PE1R 280 S4	IE4-PE0R 250 S4	K21R 280 S4	K20R 250 S4	0.864	520
IE4-PE1R 280 M4	IE4-PE0R 250 M4	K21R 280 M4	K20R 250 M4	1.011	580
IE4-PE1R 315 MX4	IE4-PE0R 315 S4	K21R 315 MX4	K20R 315 S4	1.556	980
IE4-PE1R 315 MY4	IE4-PE0R 315 M4	K21R 315 MY4	K20R 315 M4	2.50	1170
Synchronous speed 1500 rpm – 4-pole version, rated frequency 50 Hz					
IE4-PE1R 63 K4	IE4-PE0R 56 K4	K21R 63 K4	K20R 56 K4	0.00019	4.8
IE4-PE1R 63 G4	IE4-PE0R 56 G4	K21R 63 G4	K20R 56 G4	0.00024	5.2
IE4-PE2R 71 K4	-	-	IE2-W21R 71 K4	0.00087	9.9
IE4-PE2R 71 G4	-	-	IE2-W21R 71 G4	0.00107	11.0
IE4-PE2R 80 K4	-	K21R 80 G4	-	0.00107	11.7
IE4-PE2R 80 G4	-	-	IE2-W21R 80 K4	0.00207	14.5
IE4-PE2R 90 S4	-	-	IE2-WE2R 90 S4	0.00260	18.0
IE4-PE1R 90 L4	IE4-PE0R 80 G4	K21R 90 L4	K20R 80 G4	0.00260	18.0
IE4-PE1R 100 L4	IE4-PE0R 90 L4	K21R 100 L4	K20R 90 L4	0.00400	23.5
IE4-PE1R 100 LX4	IE4-PE0R 100 S4	K21R 100 LX4	K20R 100 S4	0.00725	30
IE4-PE1R 112 M4	IE4-PE0R 100 L4	K21R 112 M4	K20R 100 L4	0.0090	37
IE4-PE1R 132 S4T	IE4-PE0R 100 LX4	K21R 132 S4T	K20R 100 LX4	0.0110	47
IE4-PE1R 132 M4	IE4-PE0R 132 S4	K21R 132 M4	K20R 132 S4	0.02	70
IE4-PE1R 160 M4	IE4-PE0R 132 M4	K21R 160 M4	K20R 132 M4	0.03	92
IE4-PE1R 160 L4	IE4-PE0R 160 S4	K21R 160 L4	K20R 160 S4	0.07	120
IE4-PE1R 180 M4	IE4-PE0R 160 M4	K21R 180 M4	K20R 160 M4	0.07	136
IE4-PE1R 180 L4	IE4-PE0R 180 S4	K21R 180 L4	K20R 180 S4	0.13	170
IE4-PE1R 200 L4	IE4-PE0R 180 M4	K21R 200 L4	K20R 180 M4	0.16	220
IE4-PE1R 225 S4	IE4-PE0R 200 M4	K21R 225 S4	K20R 200 M4	0.27	270
IE4-PE1R 225 M4	IE4-PE0R 200 L4	K21R 225 M4	K20R 200 L4	0.31	300
IE4-PE1R 250 M4	IE4-PE0R 225 M4	K21R 250 M4	K20R 225 M4	0.49	375
IE4-PE1R 250 M4	IE4-PE0R 225 M4	K21R 250 M4	K20R 225 M4	0.49	375
IE4-PE1R 280 S4	IE4-PE0R 250 S4	K21R 280 S4	K20R 250 S4	0.91	520
IE4-PE1R 280 M4	IE4-PE0R 250 M4	K21R 280 M4	K20R 250 M4	1.07	580
IE4-PE1R 280 M4	IE4-PE0R 250 M4	K21R 280 M4	K20R 250 M4	1.09	580
IE4-PE1R 315 S4	IE4-PE0R 280 S4	K21R 315 S4	K20R 280 S4	1.75	740
IE4-PE1R 315 MX4	IE4-PE0R 315 S4	K21R 315 MX4	K20R 315 S4	2.35	1000
IE4-PE1R 315 MY4	IE4-PE0R 315 M4	K21R 315 MY4	K20R 315 M4	4.22	1200

The permanent-magnet synchronous motors P21R are identical to the series K21R.
For further information regarding the terminal boxes, bearings and dimensions, please refer to Chapter 2.

Assignment table					
Type	Type	Type	J	m	
PE.R	K21R	K20R	kgm ²	kg	
Synchronous speed 1000 rpm – 6-pole version, rated frequency 50 Hz					
IE4-PE1R 132 MX6	IE4-PE0R 132 S6	K21R 132 MX6	K20R 132 S6	0.040	70
IE4-PE1R 160 M6	IE4-PE0R 132 M6	K21R 160 M6	K20R 132 M6	0.052	86
IE4-PE1R 160 L6	IE4-PE0R 160 S6	K21R 160 L6	K20R 160 S6	0.104	114
IE4-PE1R 180 L6	IE4-PE0R 160 M6	K21R 180 L6	K20R 160 M6	0.135	136
IE4-PE1R 180 L6	IE4-PE0R 160 M6	K21R 180 L6	K20R 160 M6	0.135	136
IE4-PE1R 200 L6	IE4-PE0R 180 S6	K21R 200 L6	K20R 180 S6	0.219	175
IE4-PE1R 200 LX6	IE4-PE0R 180 M6	K21R 200 LX6	K20R 180 M6	0.270	200
IE4-PE1R 225 M6	IE4-PE0R 200 M6	K21R 225 M6	K20R 200 M6	0.437	265
IE4-PE1R 250 M6	IE4-PE0R 225 M6	K21R 250 M6	K20R 225 M6	0.711	360
IE4-PE1R 280 S6	IE4-PE0R 250 S6	K21R 280 S6	K20R 250 S6	1.142	465
IE4-PE1R 280 M6	IE4-PE0R 250 M6	K21R 280 M6	K20R 250 M6	1.423	520
IE4-PE1R 315 S6	IE4-PE0R 280 S6	K21R 315 S6	K20R 280 S6	2.275	690
IE4-PE1R 315 M6	IE4-PE0R 280 M6	K21R 315 M6	K20R 280 M6	2.875	800
IE4-PE1R 315 MX6	IE4-PE0R 315 S6	K21R 315 MX6	K20R 315 S6	3.110	890
IE4-PE1R 315 MY6	IE4-PE0R 315 M6	K21R 315 MY6	K20R 315 M6	5.285	1050
IE4-PE1R 315 L6	IE4-PE0R 315 L6	K21R 315 L6	K20R 315 L6	5.940	1250
IE4-PE1R 315 LX6	IE4-PE0R 315 LX6	K21R 315 LX6	K20R 315 LX6	7.644	1460

The permanent-magnet synchronous motors P21R are identical to the series K21R.
For further information regarding the terminal boxes, bearings and dimensions, please refer to Chapter 2.

Assignment table

Type	Type	J	m		
P21R	K21R	kgm ²	kg		
Synchronous speed 3000 rpm – 4-pole version, rated frequency 100 Hz					
P21R 63 K4	P20R 56 K4	K21R 63 K2	K20R 56 K2	0.00019	4.8
P21R 63 G4	P20R 56 G4	K21R 63 G2	K20R 56 G2	0.00024	5.2
P21R 71 K4	P20R 63 K4	K21R 71 K2	K20R 63 K2	0.00040	6.8
P21R 71 G4	P20R 63 G4	K21R 71 G2	K20R 63 G2	0.00050	7.8
P21R 80 K4	P20R 71 K4	K21R 80 K2	K20R 71 K2	0.00087	10.6
P21R 80 G4	P20R 71 G4	K21R 80 G2	K20R 71 G2	0.00107	11.7
P21R 90 S4	P20R 80 K4	K21R 90 S2	K20R 80 K2	0.00207	15.5
P21R 90 L4	P20R 80 G4	K21R 90 L2	K20R 80 G2	0.00260	18.0
P21R 100 L4	P20R 90 L4	K21R 100 L2	K20R 90 L2	0.00400	23.5
P21R 112 MY4	P20R 100 S4	K21R 112 M2	K20R 100 S2	0.00725	31.0
P21R 132 M4	P20R 132 S4	K21R 132 M4	K20R 132 S4	0.024	72
P21R 160 M4	P20R 132 M4	K21R 160 M4	K20R 132 M4	0.033	92
P21R 160 L4	P20R 160 S4	K21R 160 L4	K20R 160 S4	0.065	120
P21R 180 M4	P20R 160 M4	K21R 180 M4	K20R 160 M4	0.076	135
P21R 180 L4	P20R 180 S4	K21R 180 L4	K20R 180 S4	0.126	170
P21R 200 L4	P20R 180 M4	K21R 200 L4	K20R 180 M4	0.162	200
P21R 225 S4	P20R 200 M4	K21R 225 S4	K20R 200 M4	0.264	270
P21R 225 M4	P20R 200 L4	K21R 225 M4	K20R 200 L4	0.303	300
P21R 250 M4	P20R 225 M4	K21R 250 M4	K20R 225 M4	0.485	375
P21R 280 S4	P20R 250 S4	K21R 280 S4	K20R 250 S4	0.911	520
P21R 280 M4	P20R 250 M4	K21R 280 M4	K20R 250 M4	1.065	580
P21R 315 S4	P20R 280 S4	K21R 315 S4	K20R 280 S4	1.75	740
P21R 315 M4	P20R 280 M4	K21R 315 M4	K20R 280 M4	1.75	840
Synchronous speed 1500 rpm – 4-pole version, rated frequency 50 Hz					
P21R 63 K4	P20R 56 K4	K21R 63 K4	K20R 56 K4	0.00019	4.8
P21R 63 G4	P20R 56 G4	K21R 63 G4	K20R 56 G4	0.00024	5.2
P21R 71 K4	P20R 63 K4	K21R 71 K4	K20R 63 K4	0.00040	6.8
P21R 71 G4	P20R 63 G4	K21R 71 G4	K20R 63 G4	0.00050	7.8
P21R 80 K4	P20R 71 K4	K21R 80 K4	K20R 71 K4	0.00087	10.6
P21R 80 G4	P20R 71 G4	K21R 80 G4	K20R 71 G4	0.00107	11.7
P21R 90 S4	P20R 80 K4	K21R 90 S4	K20R 80 K4	0.00207	15.5
P21R 90 L4	P20R 80 G4	K21R 90 L4	K20R 80 G4	0.00260	18.0
P21R 100 L4	P20R 90 L4	K21R 100 L4	K20R 90 L4	0.00400	23.5
P21R 100 LX4	P20R 100 S4	K21R 100 LX4	K20R 100 S4	0.00725	30.0
P21R 112 M4	P20R 100 L4	K21R 112 M4	K20R 100 L4	0.0090	37.0
P21R 132 S4T	P20R 100 LX4	K21R 132 S4T	K20R 100 LX4	0.0110	47.0
P21R 132 M4	P20R 132 S4	K21R 132 M4	K20R 132 S4	0.02	70
P21R 160 M4	P20R 132 M4	K21R 160 M4	K20R 132 M4	0.03	92
P21R 160 L4	P20R 160 S4	K21R 160 L4	K20R 160 S4	0.07	120
P21R 180 M4	P20R 160 M4	K21R 180 M4	K20R 160 M4	0.08	136
P21R 180 L4	P20R 180 S4	K21R 180 L4	K20R 180 S4	0.13	170
P21R 200 L4	P20R 180 M4	K21R 200 L4	K20R 180 M4	0.16	200
P21R 225 S4	P20R 200 M4	K21R 225 S4	K20R 200 M4	0.27	270
P21R 225 M4	P20R 200 L4	K21R 225 M4	K20R 200 L4	0.31	300
P21R 250 M4	P20R 225 M4	K21R 250 M4	K20R 225 M4	0.49	380
P21R 280 S4	P20R 250 S4	K21R 280 S4	K20R 250 S4	0.94	535
P21R 280 M4	P20R 250 M4	K21R 280 M4	K20R 250 M4	1.09	600
P21R 315 S4	P20R 280S 4	K21R 315 S4	K20R 280S 4	1.79	740
P21R 315 S4	P20R 280M 4	K21R 315 S4	K20R 280M 4	2.07	840
P21R 315 MX4	P20R 315 S4	K21R 315 MX4	K20R 315 S4	2.41	1000
P21R 315 MY4	P20R 315 M4	K21R 315 MY4	K20R 315 M4	4.22	1200
P21R 315 L4	P20R 315 L4	K21R 315 L4	K20R 315 L4	5.27	1450

The permanent-magnet synchronous motors P21R are identical to the series K21R.
For further information regarding the terminal boxes, bearings and dimensions, please refer to Chapter 2.

Assignment table

Type	Type	J	m		
P21R	K21R	kgm ²	kg		
Synchronous speed 1000 rpm – 6-pole version, rated frequency 50 Hz					
P21R 132 MX6	P20R 132 S6	K21R 132 MX6	K20R 132 S6	0.040	70
P21R 160 M6	P20R 132 M6	K21R 160 M6	K20R 132 M6	0.052	86
P21R 160 L6	P20R 160 S6	K21R 160 L6	K20R 160 S6	0.103	114
P21R 180 L6	P20R 160 M6	K21R 180 L6	K20R 160 M6	0.135	136
P21R 200 L6	P20R 180 S6	K21R 200 L6	K20R 180 S6	0.223	175
P21R 200 LX6	P20R 180 M6	K21R 200 LX6	K20R 180 M6	0.270	200
P21R 225 M6	P20R 200 M6	K21R 225 M6	K20R 200 M6	0.437	265
P21R 250 M6	P20R 225 M6	K21R 250 M6	K20R 225 M6	0.721	360
P21R 280 S6	P20R 250 S6	K21R 280 S6	K20R 250 S6	1.198	465
P21R 280 M6	P20R 250 M6	K21R 280 M6	K20R 250 M6	1.492	520
P21R 315 S6	P20R 280 S6	K21R 315 S6	K20R 280 S6	2.367	690
P21R 315 M6	P20R 280 M6	K21R 315 M6	K20R 280 M6	2.981	800
P21R 315 MX6	P20R 315 S6	K21R 315 MX6	K20R 315 S6	3.226	880
P21R 315 MY6	P20R 315 M6	K21R 315 MY6	K20R 315 M6	5.334	1050
P21R 315 L6	P20R 315 L6	K21R 315 L6	K20R 315 L6	5.995	1250
P21R 315 LX6	P20R 315 LX6	K21R 315 LX6	K20R 315 LX6	7.714	1450
Synchronous speed 750 rpm – 8-pole version, rated frequency 50 Hz					
P21R 160 M8	P20R 132 S8	K21R 160 M8	K20R 132 S8	0.042	70
P21R 160 MX8	P20R 132 M8	K21R 160 MX8	K20R 132 M8	0.054	86
P21R 160 L8	P20R 160 S8	K21R 160 L8	K20R 160 S8	0.106	114
P21R 180 L8	P20R 160 M8	K21R 180 L8	K20R 160 M8	0.138	136
P21R 200 L8	P20R 180 S8	K21R 200 L8	K20R 180 S8		175
P21R 200 LX8	P20R 180 M8	K21R 200 LX8	K20R 180 M8		200
P21R 225 M8	P20R 200 M8	K21R 225 M8	K20R 200 M8	0.439	265
P21R 250 M8	P20R 225 M8	K21R 250 M8	K20R 225 M8	0.439	360

VEM Holding GmbH

Pirnaer Landstraße 176
01257 Dresden
Germany

Sales

Low voltage department

Tel. +49 3943 68-3127
Fax +49 3943 68-2440
E-Mail: low-voltage@vem-group.com

High voltage department

Tel. +49 351 208-3237
Fax +49 351 208-1108
E-Mail: high-voltage@vem-group.com

Drive systems department

Tel. +49 351 208-1180
Fax +49 351 208-1185
E-Mail: drive-systems@vem-group.com

VEM Service

Tel. +49 351 208-3237
Fax +49 351 208-1108
E-Mail: service@vem-group.com



For detailed information
please visit our website.

www.vem-group.com