

IL RIDUTTORE "GHA"

THE "GHA" GEARBOX / DAS "GHA" GETRIEBE



TRAMEC  HIGH THERMAL CONDUCTIVITY
HIGH THERMODYNAMIC PERFORMANCE 



 IT ABSORBS HEAT AND RETURNS
IT WITH INFRARED WAVES  TRAMEC

TRAMEC  RECYCLABLE
TOTALLY 



 ANTI-MOLD (BACTERICIDAL)
ANTIBACTERIAL CAPACITY  TRAMEC

TRAMEC  CORROSION
RESISTANCE 



 PHARMACEUTICAL
APPLICATIONS  TRAMEC

TRAMEC  LOW ENVIRONMENTAL
IMPACT 

 FOOD
APPLICATIONS  TRAMEC

TRAMEC  MARINE
APPLICATIONS 



Made in Italy

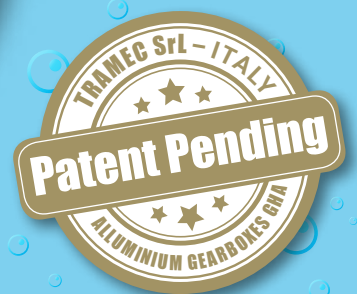



MADE IN ITALY

Per TRAMEC l'espressione "MADE IN ITALY" ha un significato molto più profondo di quanto nell'uso comune gli viene attribuito. Tutti i prodotti di TRAMEC sono il risultato di:

PROGETTAZIONE E CREATIVITA' ITALIANA

Tutti i prodotti TRAMEC sono completamente progettati in ITALIA, nella sede principale di CALDERARA di RENO (BOLOGNA), in piena "MOTOR VALLEY" e "PACKAGING VALLEY" ove la meccanica è di casa. Qui la creatività ITALIANA viene espressa dagli ingegneri di TRAMEC pienamente, con la progettazione di prodotti, anche personalizzati e con l'uso di strumenti sempre più evoluti. Il risultato è un prodotto di altissima qualità, così come quello presente nel catalogo che state sfogliando.

PRODUZIONE E MONTAGGIO

Tutti i componenti principali del prodotto TRAMEC sono il risultato della rete produttiva della nostra Azienda, che si avvale dell'esperienza e delle capacità degli artigiani del territorio.

Dall'assemblaggio di tali componenti, che viene fatto completamente dai tecnici TRAMEC che con la loro esperienza e bravura esprimono la loro capacità, nascono i riduttori di TRAMEC

SERVIZIO AL CLIENTE

L'importanza che il Cliente ha per TRAMEC, si manifesta non solo con il fornirgli un prodotto di altissima qualità, ma con un'assistenza PRE-VENDITA e POST-VENDITA all'altezza del prodotto acquistato. E' anche in questo modo, stando al fianco del Cliente, che l'ITALIANITA' viene espressa.

Tutto questo è per TRAMEC il significato di "MADE IN ITALY".

At TRAMEC "MADE IN ITALY" is an expression with a much deeper meaning, as all TRAMEC products are the result of:

ITALIAN DESIGN & CREATIVITY

TRAMEC is headquartered in CALDERARA di RENO (BOLOGNA), in the heart of Italy's famous "MOTOR VALLEY" or "PACKAGING VALLEY" where the art of performance is mastered with the science of precision. Italian design & engineering creativity is allowed to be expressed via the most advanced tools by TRAMEC engineers in the design of our standard and customized products. This creativity results in an innovative design of remarkable quality which is presented in the catalogue before you.

PRODUCTION & ASSEMBLY

The designs of TRAMEC are brought to life through the careful hands of machinists and technicians expressing the local tradition of excellence. All major components are produced, assembled, and inspected within the TRAMEC manufacturing organization. From this long tradition, expressing performance and precision into objects of exceptional quality, we introduce the TRAMEC'S GEARBOXES.

CUSTOMER CARE

Everything we do, from conception to delivery is focused upon our customers. High performance precision products made to increasingly demanding levels of quality deserve excellence before, during, and after the purchase. At TRAMEC we express our Italian culture and heritage in caring for our customers throughout the process.

From everyone at TRAMEC, this is what it means to say "MADE IN ITALY".

Für TRAMEC hat der Begriff "MADE IN ITALY" eine sehr viel wichtigere Bedeutung als die im üblichen Gebrauch geltende. Alle Produkte von TRAMEC sind das Ergebnis von:

ITALIENISCHER PLANUNG UND KREATIVITÄT

Alle Produkte von TRAMEC werden vollkommen in ITALIEN geplant, und zwar im Hauptsitz in CALDERARA di RENO (BO), mitten im "MOTOR VALLEY" und "PACKAGING VALLEY", dort wo die Mechanik vorherrscht. Hier wird die ITALIENISCHE Kreativität von den Ingenieuren von TRAMEC voll bei der mit stets noch fortschrittlicheren Instrumenten vorgenommenen Planung von Produkten, die auch kundenspezifisch sein können, voll zum Ausdruck gebracht. Das Ergebnis sind Produkte mit qualitativ sehr hochwertigen Merkmalen, so wie die im Katalog, den Sie gerade durchblättern.

PRODUKTION UND MONTAGE

Alle wichtigen Komponenten der Produkte von TRAMEC sind das Ergebnis des Produktionsnetzes unseres Unternehmens, das sich auf die Erfahrung und die Fähigkeiten der Handwerker in unserem Gebiet stützt.

Durch den Zusammenbau dieser Komponenten, der vollkommen von den erfahrenen und ausgezeichneten Technikern von TRAMEC ausgeführt wird, entsteht dann das Planetengetriebe MTA.

KUNDENDIENST

Für TRAMEC wird die Wichtigkeit der Kundschaft nicht nur damit ausgedrückt, dass ein qualitativ hochwertiges Produkt geliefert wird, sondern auch durch einen KUNDENDIENST, der vor und nach dem Verkauf auf demselben Qualitätsniveau steht, wie das Produkt selbst. Auch auf diese Art, durch den stetigen Beistand dem Kunden gegenüber, wird das ITALIENISCHE Wesen ausgedrückt.

All das zusammen bedeutet für TRAMEC "MADE IN ITALY".



Cos'è il trattamento G.H.A.® (*)

G.H.A.® è la più recente ed innovativa tecnologia applicabile alle superfici di tutte le leghe a base alluminio. Consiste in uno speciale trattamento di ossidazione anodica, con spessore da 1 a 100µm, a cui segue una sigillatura delle microporosità mediante ioni d'argento (Ag+).

What is G.H.A.® (*)

The G.H.A.® is the most recent and innovative technology applicable to the surface of all aluminum -base alloys. It consists of a special anodic oxidation treatment, with thickness ranging from 1 to 100 µm, followed by the sealing of the micro porosities through silver ions (Ag+).

Was ist die G.H.A.® -Behandlung (*)

G.H.A.® ist die modernste, innovativste auf allen aus Aluminiumlegierungen bestehenden Oberflächen anwendbare Technologie. Sie besteht aus einer speziellen Behandlung durch anodische Oxidation mit einer Stärke von 1 bis zu 100µm, darauf folgt dann eine Versiegelung der Mikroporen durch Silberionen (Ag+). Die anodische Oxidation ist für Alumi-

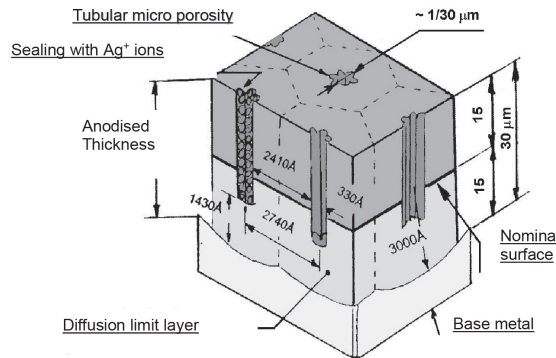

L'Ossidazione Anodica è per le leghe a base alluminio il trattamento protettivo più congeniale e sicuro fra tutti gli altri perché è inasportabile, infatti l'alluminio della base si trasforma, durante il processo galvanico, in ossido di alluminio (Al₂O₃), generando uno strato protettivo di tipo ceramico molto duro, refrattario al calore ed inasportabile. I cristalli dell'ossido di alluminio (Al₂O₃) hanno una struttura a nido d'ape con cristalli ottaedrici molto dura e compatta, con un foro capillare al centro degli ottaedri che penetra quasi fino alla base degli stessi.

The Anodic Oxidation of aluminum – base alloys is the most suitable and safe protection treatments because it's unremovable, in fact, during the galvanic process, the aluminum base is transformed into aluminum oxide (Al₂O₃), generating a very hard protective layer, similar to ceramic, which is heat resistant and not removable. Aluminum oxide crystals are disposed in a honeycomb structure, very hard and compact, with a capillary hole at the center of the octahedron and nearly reaching the base of them.

umlegierungen die geeignetste und sicherste Schutzbehandlung, da sie nicht entfernt werden kann. Das Aluminium wird nämlich während der Galvanisierung in Aluminiumoxid (Al₂O₃) verwandelt und erzeugt so eine sehr harte, keramiktartige Schutzschicht, die wärmebeständig und nicht entfernbar ist. Die Aluminiumoxidkristalle (Al₂O₃) haben eine wabenförmige, sehr harte und kompakte Struktur mit achtfächigen Kristallen. In der Mitte der Oktaeder befindet sich eine feine Bohrung, die beinahe bis auf die Grundfläche derselben reicht.

Questi pori sono anche ricettacolo di sporco e di microorganismi tanto che le superfici anodizzate si macchiano. Per questa ragione vengono spesso ricoperte con sostanze coloranti che sigillano i pori (nero o altri colori). I ricercatori della società SOUKEN di Kyoto hanno studiato la possibilità di sigillare i pori dei cristalli degli ossidi anodici, mediante uno speciale processo galvanico impiegando ioni Ag+, trasformando così quello che era considerato un difetto, la porosità, in un pregio in quanto queste costituiscono piccoli serbatoi per gli ioni Ag+, risultando così uniformemente distribuiti sulla superficie e permanentemente presenti durante l'usura delle stesse.

These pores are also a receptacle for dirt and microorganisms so that the anodized surfaces easily get stained. For this reason they are often treated with coloring substances to seal the pores (with black or other colors). The researchers of the company SOUKEN of Kyoto studied the possibility of sealing the crystal pores of the anodic oxides by a special galvanic process using Silver ions Ag+, thereby transforming what was considered a defect (the porosity) into an advantage. In fact, these pores provide a proper reservoir for Ag+ ions, thus being uniformly distributed on the surface and permanently present during the wear of the oxide layer. The G.H.A.® process (Golden Hard Anodizing) was then patented (Patent No. EP1207220). The high hardness of anodic oxide, HV 500-600, combined with the extraordinary properties of silver ions, see Table 1, gives to the treated surface biotechnological characteristics of great practical interest, see Table 2, ranging from the pharmaceutical and food industry to the technical and scientific fields. Not to mention the high hardness and refractory heat factor that are typical of the anodic oxides.

In diesen Poren lagern sich auch Schmutz und Mikroorganismen ab, sodass die eloxierten Oberflächen fleckig werden. Aus diesem Grund werden sie oft mit Farbstoffen überdeckt, durch die die Poren geschlossen werden (in Schwarz oder auch in anderen Farben). Die Forscher der Firma SOUKEN aus Kyoto haben die Möglichkeit untersucht, die Poren der Kristalle der anodischen Oxide mit einem speziellen Galvanisierungsverfahren zu versiegeln, bei dem Silberionen verwendet werden, sodass das, was bisher als Defekt betrachtet wurde, nämlich die Poren, nun zu einem Vorteil wird, da diese winzigen Vertiefungen zu Aufnahmeflächen für die Silberionen werden und so auf der gesamten Oberfläche gleichmäßig verteilt und während ihres Verschleißes ständig vorhanden sind. Der G.H.A.®-Prozess (Golden Hard Anodizing) wurde patentiert (Patent Nr. EP1207220). Die außerordentliche Härte des anodischen Oxids, HV 500-600, verleiht der behandelten Oberfläche zusammen mit den exzellenten Merkmalen der Silberionen, siehe Tabelle 1, biotechnologische Merkmale, die für die Anwendungen sehr interessant sind, siehe Tabelle 2, und von der Pharmaindustrie bis hin zu technischen und wissenschaftlichen Sektoren gehen. Ferner darf nicht vergessen werden, dass die außerordentliche Härte und die Hitzebeständigkeit weitere Merkmale der anodischen Oxide darstellen.

Tab. 1

PROPRIETÀ TRATTAMENTO GHA® CON GLI IONI ARGENTO Ag+ (*)	PROPERTY OF GHA® TREATMENT WITH SILVER IONS Ag+ (*)	MERKMALE DER GHA®-BEHANDLUNG MIT SILBERIONEN AG+ (*)
Basso coefficiente d'attrito, autolubrificazione e resistenza all'usura.	<i>Low coefficient of friction, self-lubrication and wear resistance.</i>	Niedriger Reibungskoeffizient, selbstschmierend und Verschleißbeständig.
Resistenza alla corrosione	<i>Corrosion resistance</i>	Korrosionsbeständig
Elevata conducibilità termica ed alto rendimento termodinamico	<i>High thermal conductivity and high thermodynamic efficiency</i>	Hohe Wärmeleitfähigkeit und hoher thermodynamischer Wirkungsgrad
Elevata capacità antistatica	<i>High antistatic capacity</i>	Beträchtliche antistatische Leistungen
Capacità di assorbire calore e di rimetterlo con onde infrarosse	<i>Ability to absorb heat and diffuse it as ultra-infrared waves</i>	Fähigkeit zur Aufnahme von Wärme und deren erneute Ausgabe über Infrarotstrahlen
Elevata capacità antibatterica ed antimuffa (Battericida)	<i>High antibacterial capacity and anti-mold (Antibacterial)</i>	Hohe antibakterielle und gegen Schimmelbildung wirkende Leistungsfähigkeit (Bakterizid)

CARATTERISTICHE BIOTECNOLOGICHE (*) BIOTECHNOLOGY FEATURES (*) BIOTECHNOLOGISCHE MERKMALE (*)						
Materiale Material Material	Durezza HV Hardness HV HV - Härte	Temperatura di Fusione Melting temperature Schmelztemperatur	Coefficiente di attrito Coefficient of friction Reibungskoeffizient	Capacità Batteriostatica Bacteriostatic capacity Bakteriostatische Fähigkeit	Resistenza alla corrosione SST Corrosion resistance SST Korrosionsbeständigkeit SST	Resistenza all'usura Resistance to consumption Verschleißbeständigkeit
Lega di Alluminio Aluminum Alloy Aluminiumlegierung	70÷100	680°C	0,44	nessuna none Keine	100 h	1000 h
Ossido di Alluminio con trattamento G.H.A.® Aluminum oxide with G.H.A.® treatment Mit dem G.H.A.® Verfahren behandeltes Aluminiumoxid	500÷550	2100°C	0,025	elevatissima high sehr hoch	10.000 h	1.000.000 h
Ossidazione dura Hard oxidizing harte Oxidation	500÷550	2100°C	0,15	nessuna none Keine	200 ÷ 500 h	1.000 h

Pertanto il coating G.H.A.® in combinazione di una appropriata lega leggera (nel nostro caso l'alluminio) può essere considerato, da parte dei progettisti, un vero e proprio nuovo materiale e può rappresentare una valida alternativa sia a materiali costosi come leghe di Titanio o acciai inox o ad acciai rivestiti di coating blasonati e costosi come TIN – PVD – CVD – Cromo duro – Nichel chimico – Nichel-Teflon etc.

Therefore the G.H.A.® coating, if combined with the appropriate aluminum alloy, can be considered by the designers as a real new material and can be a good alternative to expensive metals such as titanium alloys, stainless steel or steel treated by expensive and well known coatings like TIN – PVD – CVD – Hard chromium – Chemical Nickel – Nickel – Teflon etc.

Daher kann die G.H.A.®-Beschichtung zusammen mit einer geeigneten Leichtlegierung (in unserem Fall Aluminium) von den Planern eigentlich als ein neues Material betrachtet werden, und kann sowohl für teure Materialien wie Titanlegierungen oder Edelstahl als auch für Stahl mit teuren und edlen Beschichtungen wie TIN – PVD – CVD – Hartchrom – chemisches Nickel – Nickel-Teflon usw. eine wertvolle Alternative darstellen.

(*): Tratto dal documento "Valutazione Effetto Battericida su Trattamento GHA (a cura del centro servizi analisi e prove di GHA Europe)"

(*): Taken from the document "Valutazione Effetto Battericida su Trattamento GHA (a cura del centro servizi analisi e prove di GHA Europe)"

(*)Auszug aus dem Dokument "Auswertung der bakterientötenden Auswirkung bei GHA-Behandlung (verfasst vom Zentrum für Analysen und Tests von GHA Europe)"

La Certificazione ISO 22196:2011 - JIS Z 2801:2010

L'Organizzazione Internazionale per la Standardizzazione (ISO) crea e pubblica norme internazionali, requisiti, linee guida e parametri allo scopo di fornire un criterio univoco e razionale per garantire chiarezza e sicurezza nel lavoro. La creazione di Standard Internazionali favorisce quindi lo scambio di idee e incentiva il mercato minimizzando gli errori ed evitando le incertezze. La normativa a cui abbiamo fatto riferimento è la ISO 22196:2011, relativa alla misurazione dell'attività antibatterica, la quale a sua volta si basa sul metodo della precedente JIS Z 2801:2010. Queste norme pongono le linee guida sui metodi di analisi da eseguire, sui materiali e i criteri di valutazione per interpretare i risultati in modo da fornire un criterio univoco ed uno standard per l'analisi.

TRAMEC ha eseguito propri test, oltre a quelli effettuati dalla società "G.H.A. Europe S.r.L." per l'ottenimento della "Certificazione ISO 22196:2011", che hanno confermato che il proprio riduttore Brevettato denominato "GHA" risponde a tale normativa. Dal superamento di tali test di laboratorio, il riduttore "GHA" di TRAMEC ha ottenuto a sua volta la "Certificazione ISO 22196:2011".

I test eseguiti da TRAMEC sono stati effettuati dal Laboratorio:

CEPRA srl - Via dei Macabracchia, 8 - 40033 Casalecchio di Reno (BO) - ITALY

C.F. e P.IVA 02002271209 Registro imprese di Bologna n. 02002271209 - R.E.A. n 404040/BO

Azienda con sistema gestione qualità certificato UNI EN ISO 9001:2008 Nr 50 100 9099"

I test eseguiti da G.H.A. Europe S.r.L. sono stati effettuati dal Laboratorio:

3A Laboratori srl - Via A. Volta, 1/d 35020 Maserà di Padova (PD) - ITALY
C.F. e P.IVA 04296730288 Registro imprese di Padova - R.E.A. n 378402/PD
Accreditamento ACCREDIA n. 1165, conformità UNI CEI EN ISO/IEC 17025:2005

Certificazione ISO 9001:2008 presso CSQA (n. 14270) valida all'interno del circuito IQNet (certificato n. IT-29858)

ISO 22196 : 2011 - JIS Z 2801: 2010 Certification

The International Organization for Standardization (ISO) creates and advertises for international standards, requirements, guidelines and parameters in order to provide an universal and unequivocal criterion to ensure clarity and safety of work. The creation of International Standards therefore encourages the exchange of ideas and provides incentives for the market by minimizing errors and avoiding uncertainties. The regulation we referred to is ISO 22196: 2011, relating to the measurements of antibacterial activity, which in turn is based on the method of the previous JIS Z 2801: 2010. These standards set guidelines on the methods of analysis to be carried out, on the materials, as well as the evaluation criteria to interpret the results so to provide a unique criterion and a standard for analysis.

TRAMEC has performed its own tests, beside those carried out by "G.H.A. Europe S.r.L." for obtaining the "ISO 22196: 2011 Certification", which confirmed that its patented GHA gearbox fully complies with this regulation. After successfully passing these laboratory tests, TRAMEC "GHA" gearbox also obtained "ISO 22196: 2011" certification.

The tests performed by TRAMEC were carried out at the Laboratory:

CEPRA srl - Via dei Macabracchia, 8 - 40033 Casalecchio di Reno (BO) - ITALY

C. F. And P.IVA 02002271209 Bologna Register no. 02002271209 - R.E.A. N 404040 / BO

Company with certified quality management system UNI EN ISO 9001: 2008 Nr 50 100 9099 "

Tests by G.H.A. Europe S.r.L. were carried out at the Laboratory:

3A Laboratori srl - Via A. Volta, 1 / d 35020 Maserà di Padova (PD) - ITALY
C. F. And P.IVA 04296730288 Padua Business Register - R.E.A. N 378402 / PD

Accreditation ACCREDIA n. 1165, in compliance with UNI EN ISO / IEC 17025: 2005

Certification ISO 9001: 2008 at CSQA (No 14270) valid within the IQNet circuit (Certificate No. IT-29858)

Zertifizierung nach ISO 22196:2011 - JIS Z 2801:2010

Die internationale Organisation für Normung (ISO) verfasst und veröffentlicht internationale Normen, Anforderungen, Leitfäden und Parameter mit dem Zweck, eindeutige und rationelle Kriterien zu liefern, um Klarheit und Sicherheit bei der Arbeit zu gewährleisten. Die Erstellung von internationalen Standards fördert daher den Austausch von Ideen und hat einen positiven Einfluss auf die Marktlage, da Fehler auf ein Minimum reduziert und Zweifel vermieden werden. Die Norm, auf die wir Bezug nehmen, ist die ISO 22196:2011, die sich auf die Messung des antibakteriellen Wirkung bezieht und sich ihrerseits wiederum auf die Methode der vorherigen JIS Z 2801:2010 stützt. Diese Normen legen die Leitfäden über die Methoden der auszuführenden Tests, über die Materialien und die Beurteilungskriterien fest, damit die Ergebnisse dann so bewertet werden, dass sie ein eindeutiges Kriterium darstellen und als Standard für die Analyse gelten.

TRAMEC hat außer den von der Gesellschaft "G.H.A. Europe S.r.L." auch eigene Tests ausgeführt, um die Zertifizierung ISO 22196:2011" zu erzielen. Diese Tests haben bestätigt, dass das firmeneigenen, patentierte Getriebe mit der Bezeichnung "GHA" dieser Norm entspricht. Da das Getriebe "GHA" von TRAMEC diese Labortests bestanden hat, wurde ihm die "Zertifizierung ISO 22196:2011" verliehen.

Die von TRAMEC vorgenommenen Tests wurden von folgendem Labor ausgeführt:

CEPRA srl - Via dei Macabracchia, 8 - 40033 Casalecchio di Reno (BO) - ITALY

St.Nr. und USt.Nr. 02002271209 Firmenregister Bologna Nr. 02002271209 - Handelsregister Nr. 404040/BO

Unternehmen mit nach UNI EN ISO 9001:2008 zertifiziertem Qualitätsmanagement, Zertifizierungsnummer 50 100 9099"

Die von G.H.A. Europe S.r.L. ausgeführten Tests wurden im folgenden Labor vorgenommen:

3A Laboratori srl - Via A. Volta, 1/d 35020 Maserà di Padova (PD) - ITALY
St.Nr. und USt.Nr. 04296730288 Firmenregister Padua Nr. - Handelsregister Nr. 378402/PD

Akkreditierung ACCREDIA Nr. 1165, Konformität UNI CEI EN ISO/IEC 17025:2005

Zertifizierung ISO 9001:2008 bei CSQA (Nr. 14270) mit Gültigkeit auch innerhalb des IQNet-Netzwerks (Zertifikat Nr. IT-29858)

Brevetto TRAMEC

“RIDUTTORE MECCANICO TRATTATO CON IONI DI ARGENTO”

TRAMEC ha depositato un proprio brevetto, per proteggere la proprietà intellettuale legata al riduttore denominato “GHA”. L’uso dell’argento e/o degli ioni di argento applicato ad un riduttore in qualsiasi forma è protetto legalmente dalle leggi vigenti e di cui TRAMEC ne possiede totalmente i diritti.

Tali diritti saranno, se necessario, fatti rivalere da TRAMEC nelle sedi e nei luoghi previsti.

Il deposito del brevetto d’invenzione è stato curato da :

BUGNION S.p.A. – Intellectual Property Dipartimento Brevetti – Ufficio di Bologna Via di Corticella, 87 – Bologna (BO) ITALY

IL PRIMO RIDUTTORE “ECOLOGICO”

Possiamo considerare il riduttore “GHA” di TRAMEC, il primo riduttore “Ecologico”, grazie ad altre caratteristiche che lo compongono e che qui riassumiamo:

-Tutti i componenti di cui è costituito non sono inquinanti e sono completamente riciclabili.

-Per la sua pulizia viene consigliato l’utilizzo di prodotti “Ecologici” con PH tendenzialmente neutro. E’ sconsigliato l’uso di prodotti inquinanti quali la “Soda Caustica” (vedi manuale “USO e Manutenzione”).

-Per produrre un riduttore “GHA”, è necessaria molta meno energia, rispetto ad un suo corrispondente prodotto in acciaio INOX.

Patent TRAMEC

“MECHANICAL GEARBOX REATED WITH SILVER IONS”

TRAMEC deposited its own patent to protect the intellectual property connected with the gearbox named “GHA”. The use of silver and / or silver ions applied to a gearbox in any form is legally protected by the laws in force . All rights reserved by TRAMEC.

TRAMEC will make use of these rights , if necessary, in the venues and places provided by law.

The patent filing has been cared for by :

BUGNION S.p.A. - Intellectual Property Patent Department - Office of Bologna Via di Corticella, 87 - Bologna (BO) ITALY

THE FIRST “ECO - FRIENDLY “ GEARBOX

The “GHA” gearbox manufactured by TRAMEC could be considered as the first “ecological “ gearbox, thanks to the additional characteristics summarized here below:

- Made by non-polluting and completely recyclable components.

- Can be cleaned with ECO-sustainable and Non polluting products with pH potentially neutral, while its cleaning with highly polluting products such as “sodium hydroxide “ is not recommended. See manual (USE & MAINTENANCE).

- Much less energy is needed for the manufacturing of a “GHA” gearbox if compared to the corresponding stainless steel product.

Brevetto TRAMEC

“MECHANISCHES, MIT SILBERIONEN BEHANDELTES GETRIEBE”

TRAMEC hat ein Patent angemeldet, um das geistige Eigentum im Zusammenhang mit dem Getriebe mit der Bezeichnung „GHA“ zu schützen. Der gebrauch von Silber und/oder Silberionen, die an einem Getriebe mit beliebiger Form angewendet werden, ist durch die geltende Gesetzgebung geschützt, und TRAMEC ist alleiniger Besitzer aller diesbezüglichen Rechte.

Diese Rechte werden von TRAMEC bei Bedarf an den vorgesehenen Stellen von TRAMEC geltend gemacht.

Die Anmeldung des Patents für die Erfindung wurde durch folgende Firma ausgeführt:

BUGNION S.p.A. – Intellectual Property Abteilung Patente – Büros von Bologna Via di Corticella, 87 – Bologna (BO) ITALY

DAS ERSTE “UMWELTFREUNDLICHE” GETRIEBE

Das Getriebe „GHA“ von TRAMEC kann dank den Merkmalen, durch der er sich auszeichnet, als das erste „umweltfreundliche Getriebe betrachtet werden. Hier die Zusammenfassung dieser Merkmale:

- Alle Komponenten, aus denen das Getriebe besteht, sind nicht umweltverschmutzend und komplett **recyclebar**.

- Für die Reinigung wird **empfohlen**, „**umweltfreundliche**“ Produkte mit einem möglichst neutralen PH zu verwenden. Vom Gebrauch von umweltverschmutzenden Produkten, wie zum Beispiel “NATRIUMHYDROXID”, wird abgeraten.(Siehe Handbuch “GEBRAUCH und WARTUNG”)

- Für die **Herstellung eines „GHA“-Getriebes** ist der **Energiebedarf geringer** als für ein gleichwertiges Produkt aus Edelstahl.

GHA - PREMIUM

Riduttori a vite senza fine con carcassa in lega d'alluminio sottoposta a trattamento GHA potenziato, disponibili dalla grandezza 30 alla 75.

I riduttori della serie PREMIUM presentano altissima resistenza alla corrosione (oltre 2100 ore in test di nebbia salina NSS) ed eccellenti proprietà battericide (efficacia provata contro batteri quali *Escherichia coli*, *Staphylococcus aureus*, etc.).

Inoltre, lo speciale profilo esterno liscio del corpo del riduttore è stato appositamente progettato per consentirne la massima pulizia, testandone in laboratorio la resistenza ai detergenti standard (vedi sezione pulizia del prodotto).

Tutti i riduttori della serie PREMIUM sono provvisti di albero cavo in acciaio inox AISI 316, bulloneria inox, olio alimentare e paraoli alimentari certificati FDA.

In virtù delle loro caratteristiche uniche, i riduttori della serie PREMIUM costituiscono la soluzione ideale per un'ampia gamma di applicazioni in ambienti sensibili nei settori ALIMENTARE, FARMACEUTICO e MARINO.

Worm reducers with aluminium alloy casing subjected to enhanced GHA treatment, available from size 30 to 75.

*PREMIUM series reducers have very high corrosion resistance (over 2100 hours in NSS salt spray tests) and excellent bactericidal properties (proven efficacy against bacteria, such as *Escherichia coli*, *Staphylococcus aureus*, etc.).*

Furthermore, the special smooth external profile of the reducer body has been specially designed to allow for maximum cleanliness, having lab-tested the resistance to standard detergents (see the product cleaning section).

All PREMIUM series reducers are fitted with an AISI 316 stainless steel hollow shaft, stainless steel nuts and bolts, food-grade oil and FDA certified food-grade seals.

Thanks to their unique characteristics, the PREMIUM series reducers are the ideal solution for a wide range of applications in sensitive environments in the FOOD, PHARMACEUTICAL and MARINE sectors.

Schneckengetriebe in einem Aluminiumgehäuse, das mit verstärktem GHA-Verfahren behandelt wurde, erhältlich in den Größen von 30 bis 75.

Die Getriebe der Serie PREMIUM sind äußerst korrosionsbeständig (mehr als 2100 Stunden beim Test in salzhaltigem Sand NSS) und verfügen über ausgezeichnete bakterientötende Merkmale (die Wirksamkeit wurde bei Bakterien wie *Escherichia coli*, *Staphylococcus aureus*, usw.) getestet.

Das spezielle, glatte Außenprofil des Getriebekörpers wurde eigens dafür entwickelt, um die bestmögliche Reinigung zu gewährleisten, hierfür wurde in den Labors die Beständigkeit gegenüber Standard-Reinigungsmitteln getestet (siehe Abschnitt Reinigung des Produkts).

Alle Getriebe der Serie PREMIUM sind mit einer Hohlwelle aus Edelstahl AISI 316, Schrauben und Bolzen aus Edelstahl und lebensmitteltauglichem Öl und entsprechenden Ölabdichtungen mit FDA-Zertifizierung ausgestattet.

Dank ihren einzigartigen Merkmalen stellen die Getriebe der Serie PREMIUM die ideale Lösung für eine große Anzahl von Anwendungen in empfindlichen Bereichen in der LEBENSMITTEL-, PHARMA- UND SCHIFFFAHRTSBRANCHE dar.

GHA

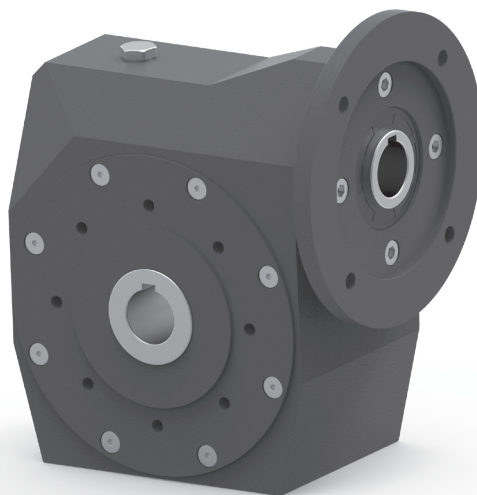

GHA - CLASSIC

Fanno parte di questo gruppo i riduttori a vite senza fine serie GK, disponibili dalla grandezza 30 alla 89, ed i riduttori ad assi ortogonali serie GT, disponibili dalla grandezza 56 alla 75.

Dotati di carcassa in lega d'alluminio pressofuso su cui viene applicato il trattamento GHA standard, i riduttori della serie CLASSIC presentano le medesime elevatissime proprietà antibatteriche della serie PREMIUM e resistenza alla corrosione standard (250 ore in test di nebbia salina NSS).

Le carcasse hanno lo stesso profilo esterno dei riduttori TRAMEC standard (non GHA) e sono certificate HACCP per applicazioni in ambito alimentare.

Tutti i riduttori della serie GHA CLASSIC sono inoltre provvisti di albero cavo in acciaio inox AISI 316, bulloneria inox, olio alimentare e paraoli alimentari certificati FDA.

In virtù delle loro caratteristiche uniche, i riduttori della serie GHA CLASSIC sono particolarmente idonei per le applicazioni in campo alimentare (non a contatto con gli alimenti) e farmaceutico.

This group includes GK series worm reducers, available from size 30 to 89, and the GT series orthogonal axis reducers, available from size 56 to 75.

Fitted with a die cast aluminium alloy casing on which the standard GHA treatment is applied, the CLASSIC series reducers have the same very high antibacterial properties as the PREMIUM series and standard corrosion resistance (250 hours in NSS salt spray tests).

The casings have the same external profile as the standard TRAMEC reducers (non-GHA) and are HACCP certified for food applications.

All GHA CLASSIC series reducers are also fitted with an AISI 316 stainless steel hollow shaft, stainless steel nuts and bolts, food-grade oil and FDA certified food-grade seals.

Thanks to their unique characteristics, the GHA CLASSIC series gearboxes are particularly suitable for applications in food (not in contact with food) and pharmaceutical sectors.

Zu dieser Gruppe gehören die Schneckengetriebe der Serie GK, die in den Größen von 30 bis 89 erhältlich sind, und die Kegelstirradgetriebe der Serie GT, die in den Größen von 56 bis 75 erhältlich sind.

Die mit einem Gehäuse aus der Standard-GHA-Behandlung unterzogenem Aluminiumdruckguss ausgestatteten Getriebe der Serie CLASSIC verfügen über dieselben bakterientötenden Merkmale wie diejenigen der Serie PREMIUM, und ihre Korrosionsbeständigkeit ist standardmäßig (250 Stunden beim Test mit salzhaltigem Nebel NSS).

Die Gehäuse haben dasselbe Außenprofil wie die Standardgetriebe von TRAMEC (die nicht GHA-behandelten), und sie sind für Anwendungen im Lebensmittelbereich HACCP-zertifiziert.

Alle Getriebe der Serie GHA CLASSIC sind mit einer Hohlwelle aus Edelstahl AISI 316, Schrauben und Bolzen aus Edelstahl und lebensmitteltauglichem Öl und entsprechenden Öabdichtungen mit FDA-Zertifizierung ausgestattet.

Dank ihrer einzigartigen Eigenschaften sind die Getriebe der Serie GHA CLASSIC besonders geeignet für Anwendungen im Lebensmittelbereich (Nicht in Kontakt mit Lebensmittel) und in der Pharmaindustrie.

GK

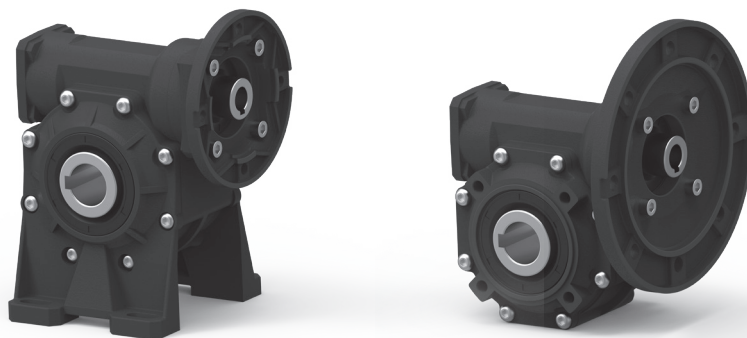

GT

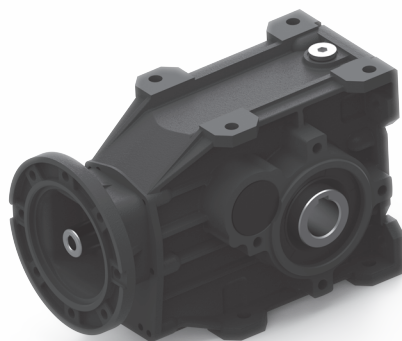

GHA - MODULAR

Riduttori a vite senza fine serie GX, disponibili dalla grandezza 30 alla 89.

Dotati di carcassa in lega d'alluminio pressofuso su cui viene applicato il trattamento GHA standard, i riduttori della serie MODULAR presentano le stesse elevatissime proprietà antibatteriche della serie PREMIUM e resistenza alla corrosione standard (250 ore in test di nebbia salina NSS).

Il profilo esterno della carcassa è quello del riduttore standard (non GHA). Versatili e robusti, questi riduttori sono adatti all'uso in ambienti alimentari secchi (mulini, etc.).

Tutti i riduttori della serie GHAMODULAR sono inoltre provvisti di albero cavo in acciaio inox AISI 316, bulloneria inox, olio alimentare e paraoli alimentari certificati FDA.

In virtù delle loro caratteristiche speciali, i riduttori della serie GHAMODULAR sono particolarmente idonei per le applicazioni in campo alimentare in ambiente secco (non a contatto con gli alimenti) e farmaceutico.

GX series worm reducers, available from size 30 to 89.

Fitted with a die cast aluminium alloy casing on which the standard GHA treatment is applied, the MODULAR series reducers have the same very high antibacterial properties as the PREMIUM series and standard corrosion resistance (250 hours in NSS salt spray tests).

The external profile of the casing is that of the standard reducer (non-GHA). These reducers are versatile and robust and suitable for use in dry food environments (mills, etc.).

All GHA MODULAR series reducers are also fitted with an AISI 316 stainless steel hollow shaft, stainless steel nuts and bolts, food-grade oil and FDA certified food-grade seals.

Thanks to their unique characteristics, the GHA MODULAR series gearboxes are particularly suitable for applications in food (not in contact with food) and pharmaceutical sectors.

Schneckengetriebe Serie GX, erhältlich in den Größen von 30 bis 89.

Die mit einem Gehäuse aus der Standard-GHA-Behandlung unterzogenem Aluminiumdruckguss ausgestatteten Getriebe der Serie MODULAR verfügen über dieselben bakterientötenden Merkmale wie diejenigen der Serie PREMIUM, und ihre Korrosionsbeständigkeit ist standardmäßig (250 Stunden beim Test mit salzhaltigem Nebel NSS).

Das Außenprofil des Gehäuses ist das selbe wie bei den Standardgetrieben (den nicht GHA-behandelten). Diese vielseitigen und robusten Getriebe sind für Anwendungen in trockenen Lebensmittelbereichen geeignet (Mühlen, usw.).

Alle Getriebe der Serie GHAMODULAR sind mit einer Hohlwelle aus Edelstahl AISI 316, Schrauben und Bolzen aus Edelstahl und lebensmitteltauglichem Öl und entsprechenden Öabdichtungen mit FDA-Zertifizierung ausgestattet.

Dank ihrer einzigartigen Eigenschaften sind die Getriebe der Serie GHAMODULAR besonders geeignet für Anwendungen im Lebensmittelbereich (Nicht in Kontakt mit Lebensmittel) und in der Pharmaindustrie.

GX

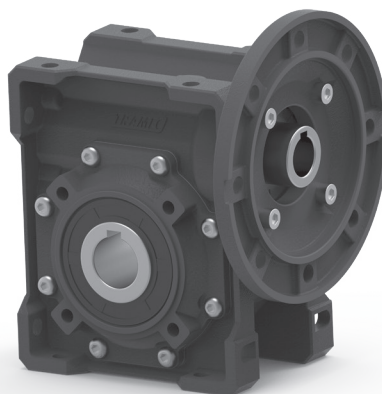

1.0	GENERALITA'	GENERAL INFORMATION	ALLGEMEINES	10
1.1	Unità di misura	<i>Measurement units</i>	Maßeinheiten	10
1.2	Fattore di servizio	<i>Service factor</i>	Betriebsfaktor	10
1.3	Selezione	<i>Selection</i>	Wahl	12
1.4	Carichi radiali e assiali	<i>Radial and axial loads</i>	Radial- und Axialbelastungen	13
1.5	Potenza termica	<i>Thermal power</i>	Thermische Leistung	14
1.6	Lubrificazione	<i>Lubrication</i>	Ölschmierung	15
1.7	Installazione	<i>Installation</i>	Einbau	15
1.8	Rodaggio	<i>Running-in</i>	Einfahren	16
1.9	Manutenzione	<i>Maintenance</i>	Wartung	16

GHA - PREMIUM

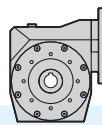

2.0	RIDUTTORI A VITE SENZA FINE GHA	GHA WORM GEARBOXES	SCHNECKENGETRIEBE GHA	17
-----	---------------------------------	--------------------	-----------------------	----

GHA - CLASSIC

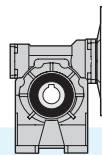

3.0	RIDUTTORI A VITE SENZA FINE GK	GK WORM GEARBOXES	SCHNECKENGETRIEBE GK	33
-----	--------------------------------	-------------------	----------------------	----

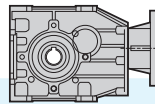

4.0	RIDUTTORI AD ASSI ORTOGONALI GT	BEVEL HELICAL GEARBOX GT	KEGELSTIRNRADGETRIEBE GT	53
-----	---------------------------------	--------------------------	--------------------------	----

GHA - MODULAR

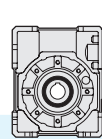

5.0	RIDUTTORI A VITE SENZA FINE GX	GX WORM GEARBOXES	SCHNECKENGETRIEBE GX	71
-----	--------------------------------	-------------------	----------------------	----



6.0	MOTORI MHA PREMIUM	MHA PREMIUM MOTORS	ENGINES MHA PREMIUM	91
-----	--------------------	--------------------	---------------------	----

7.0	MOTORI GHA CLASSIC	GHA CLASSIC MOTORS	ENGINES GHA CLASSIC	95
-----	--------------------	--------------------	---------------------	----

8.0	CONDIZIONI GENERALI DI VENDITA	TERM AND CONDITIONS OF SALE	ALLGEMEINE VERKAUFSBEDINGUNGEN	99
-----	--------------------------------	-----------------------------	--------------------------------	----

1.0 GENERALITA'
1.0 GENERAL INFORMATION
1.0 ALLGEMEINES
1.1 Unità di misura
1.1 Measurement units
1.1 Maßeinheiten

Tab. 1

SIMBOLO SYMBOL SYMBOL	DEFINIZIONE	DEFINITION	BEZEICHNUNG	UNITA' DI MISURA MEASUREMENT UNIT MAßEINHEIT
Fr₂	Carico Radiale	<i>Radial load</i>	Radialbelastung	N
Fa₂	Carico Assiale	<i>Axial load</i>	Axialbelastung	N
	Dimensioni	<i>Dimensions</i>	Abmessungen	mm
FS'	Fattore di servizio riduttore	<i>Gearbox service factor</i>	Betriebsfaktor des Getriebes	
FS	Fattore di servizio dell'applicazione	<i>Application service factor</i>	Betriebsfaktor der Anwendung	
i_n	Rapporto di riduzione	<i>Reduction ratio</i>	Untersetzungsverhältnis	
ir	Rapporto di trasmissione reale	<i>Actual reduction ratio</i>	Reelle Untersetzung	
n₁	Velocità albero entrata	<i>Input speed</i>	Antriebsdrehzahl	min⁻¹
n₂	Velocità albero uscita	<i>Output speed</i>	Abtriebsdrehzahl	min⁻¹
η	Rendimento	<i>Efficiency</i>	Wirkungsgrad	
IEC	Motori accoppiabili	<i>Motor options</i>	Passende Motoren	
kg	Massa	<i>Mass</i>	Masse	kg
P	Potenza riduttore	<i>Motor gearbox</i>	Getriebeleistung	kW
P'	Potenza richiesta in entrata	<i>Power required at input</i>	Erforderliche Leistung am Antrieb	kW
Pc	Potenza corretta	<i>Corrected power</i>	Verbesserte Leistung	kW
P₁	Potenza motoriduttore	<i>Gearmotor power</i>	Getriebemotor Leistung	kW
P₂	Potenza in uscita	<i>Output power</i>	Abtriebsleistung	kW
P_{tc}	Potenza termica corretta	<i>Corrected thermal power</i>	verbesserte thermische Leistung	kW
P₁₀	Potenza termica	<i>Thermal power</i>	Thermische Leistung	kW
P'	Potenza richiesta in uscita	<i>Output power</i>	Erforderliche Abtriebsleistung	kW
Rd	Rendimento dinamico	<i>Dynamic efficiency</i>	Dynamischer Wirkungsgrad	
Rs	Rendimento statico	<i>Static efficiency</i>	statischer Wirkungsgrad	
Ta	Temperatura ambiente	<i>Ambient temperature</i>	Umgebungstemperatur	°C
T_{2M}	Momento torcente riduttore	<i>Gearbox torque</i>	Getriebe Drehmoment	Nm
T₂	Momento torcente motoriduttore	<i>Gear motor torque</i>	Getriebemotor Drehmoment	Nm
T_c	Momento torcente da utilizzare per la scelta del riduttore	<i>Torque to be used for the selection of the gearbox</i>	Drehmoment, das zur Wahl des Getriebe zu benutzen ist	Nm
T_{2'}	Momento torcente richiesto	<i>Required Torque</i>	benötigtes Drehmoment	Nm

1.2 Fattore di servizio
1.2 Service factor
1.2 Betriebsfaktor

Il fattore di servizio **FS** permette di qualificare, in prima approssimazione, la tipologia dell'applicazione tenendo conto della natura del carico (A, B, C), della durata di funzionamento h/gg (ore giornaliere) e del numero di avviamenti/ora. Il coefficiente così trovato dovrà essere uguale o inferiore al fattore di servizio del riduttore **FS'** dato dal rapporto fra la coppia nominale del riduttore **T_{2M}** indicata a catalogo e la coppia **T_{2'}** richiesta dall'applicazione.

*Service factor **FS** enables approximate qualification of the type of application, taking into account type of load (A,B,C), length of operation h/d (hours/day) and the number of starts-up/hour. The coefficient thus calculated must be equal to or lower than the gear unit service factor **FS'** which equals the ratio between **T_{2M}** (gear unit rated torque reported in the catalogue) and **T_{2'}** (torque required by the application).*

Der **FS** Betriebsfaktor ermöglicht die annähernde Bestimmung der Anwendungsart. Dabei werden Art der Last (A, B, C), Betriebsstunden pro Tag (S/T) und Anzahl der Starts pro Stunde berücksichtigt. Der so ermittelte Koeffizient sollte dem Betriebsfaktor **FS'**, der sich aus dem Verhältnis zwischen Nenndrehmoment des Getriebes **T_{2M}** (s. Katalog) und dem für die Anwendung erforderlichen Drehmoment **T_{2'}** ergibt, entweder entsprechen oder niedriger liegen.

$$FS' = \frac{T_{2M}}{T_2'} > FS$$

I valori di FS indicati nella tab. 2, sono relativi all'azionamento con motore elettrico; se utilizzato un motore a scoppio, si dovrà tenere conto di un fattore di moltiplicazione 1.3 se a più cilindri e 1.5 se monocilindro. Se il motore elettrico applicato è autotrenante, considerare un numero di avviamenti doppio di quello effettivamente richiesto.

FS values reported in table 2 refer to a drive unit equipped with an electric motor. If an internal combustion engine is used, a multiplication factor of 1.3 must be applied for a several-cylinder engine, 1.5 for a single-cylinder engine. If the electric motor is self-braking, consider twice the number of starts-up than those actually required.

Die FS Werte, die in Tabelle 2 angegeben werden, beziehen sich auf den Antrieb mit Elektromotor; falls ein Explosionsmotor verwendet wird, ist ein Multiplikationsfaktor von 1.3 für Mehrzylindermotor und von 1.5 für Einzylindermotor zu berücksichtigen. Falls der verwendete Elektromotor ein Bremsmotor ist, so ist die Zahl der tatsächlich erforderlichen Startvorgänge doppelt zu zählen.

Tab. 2

Classe di carico Load class Lastklasse	h/gg h/d St./Tag	N. AVVIAMENTI/ORA / N. START-UP/HOUR / ANZAHL DER STARTVORGÄNGE PRO STUNDE									
		2	4	8	16	32	63	125	250	500	
A	4	0.8	0.8	0.9	0.9	1.0	1.1	1.1	1.2	1.2	
	8	1.0	1.0	1.1	1.1	1.3	1.3	1.3	1.3	1.3	
	16	1.3	1.3	1.3	1.3	1.5	1.5	1.5	1.5	1.5	
	24	1.5	1.5	1.5	1.5	1.8	1.8	1.8	1.8	1.8	
	APPLICAZIONI / APPLICATIONS / ANWENDUNGEN										
Carico uniforme Uniform load Gleichmäßig verteilte Last		Agitatori per liquidi puri Alimentatori per fornaci Alimentatori a disco Filtri di lavaggio con aria Generatori Pompe centrifughe Trasportatori con carico uniforme			<i>Pure liquid agitators Furnace feeders Disc feeders Air laundry filters Generators Centrifugal pumps Uniform load conveyors</i>			Rührwerke für reine Flüssigkeiten Beschickungsvorrichtungen für Brennöfen Telleraufgeber Spülluftfilter Generatoren Kreiselpumpen Förderer mit gleichmäßig verteilter Last			

Classe di carico Load class Lastklasse	h/gg h/d St./Tag	N. AVVIAMENTI/ORA / N. START-UP/HOUR / ANZAHL DER STARTVORGÄNGE PRO STUNDE									
		2	4	8	16	32	63	125	250	500	
B	4	1.0	1.0	1.0	1.0	1.3	1.3	1.3	1.3	1.3	
	8	1.3	1.3	1.3	1.3	1.5	1.5	1.5	1.5	1.5	
	16	1.5	1.5	1.5	1.5	1.8	1.8	1.8	1.8	1.8	
	24	1.8	1.8	1.8	1.8	2.2	2.2	2.2	2.2	2.2	
	APPLICAZIONI / APPLICATIONS / ANWENDUNGEN										
Carico con urti moderati Moderate shock load Mässige Laststöße		Agitatori per liquidi e solidi Alimentatori a nastro Argani con medio servizio Filtri con pietre e ghiaia Viti per espulsione acqua Flocculatori Filtri a vuoto Elevatori a tazze Gru			<i>Liquid and solid agitators Belt conveyors Medium service winches Stone and gravel filters Dewatering screws Flocculator Vacuum filters Bucket elevators Cranes</i>			Rührwerke für Flüssigkeiten und Feststoffe Bandförderer Mittlere Winden Filter mit Steinen/Kies Abwasserschnecken Flockvorrichtungen Vakuumfilter Becherwerke Kräne			

Classe di carico Load class Lastklasse	h/gg h/d St./Tag	N. AVVIAMENTI/ORA / N. START-UP/HOUR / ANZAHL DER STARTVORGÄNGE PRO STUNDE									
		2	4	8	16	32	63	125	250	500	
C	4	1.3	1.3	1.3	1.3	1.5	1.5	1.5	1.5	1.5	
	8	1.5	1.5	1.5	1.5	1.8	1.8	1.8	1.8	1.8	
	16	1.8	1.8	1.8	1.8	2.2	2.2	2.2	2.2	2.2	
	24	2.2	2.2	2.2	2.2	2.5	2.5	2.5	2.5	2.5	
	APPLICAZIONI / APPLICATIONS / ANWENDUNGEN										
Carico con urti forti Heavy shock load Starke Laststöße		Argani per servizio pesante Estrusori Calandre per gomma Pressa per mattoni Piattatrici Mulini a sfera			<i>Heavy duty hoists Extruders Crusher rubber calendars Brick presses Planing machine Ball mills</i>			Winden für schwere Lasten Extruder Gummikalander Ziegelpressen Hobelmaschinen Kugelmühle			

1.3 Selezione

Determinare la potenza in entrata P' (in base alla coppia T_2 richiesta dall'applicazione) con la seguente formula:

1.3 Selection

Calculate input power P' (on the basis of the torque T_2 required by the application), using the following formula:

$$P' = \frac{T_2' \cdot n_2}{9550 \cdot \eta} \quad [\text{kW}]$$

1.3 Wahl

Bestimmen Sie die Antriebsleistung P' (je nach dem bei der Anwendung erforderlichen Drehmoment T_2) mit Hilfe der folgenden Formel:

Calcolare il rapporto di trasmissione con la relazione:

Calculate the transmission ratio with the following equation:

$$i_n = \frac{n_1}{n_2}$$

Berechnen Sie das Untersetzungsverhältnis mit Hilfe der Gleichung:

Scegliere il fattore di servizio FS dell'applicazione nella Tab. 2.

Select the service factor FS of the application in Table 2.

Wählen Sie den Betriebsfaktor FS der Anwendung aus der Tabelle 2 aus.

Scelta riduttore

A) $n_1 = 1400 \text{ min}^{-1}$

Si sceglierà nelle tabelle delle prestazioni dei riduttori un gruppo che in corrispondenza di un rapporto prossimo a quello calcolato ammetta una potenza:

Selecting a gearbox

A) $n_1 = 1400 \text{ min}^{-1}$

Consult the gear unit efficiency table; select a group whose ratio is close to the calculated ratio and which permits power:

Wahl des Getriebes

A) $n_1 = 1400 \text{ min}^{-1}$

Aus der Tabelle der Leistungen der Untersetzungsgetriebe wählt man eine Baugruppe aus, die ein ähnliches Untersetzungsverhältnis zu dem berechneten Wert aufweist und die die folgende Leistung zulässt:

$$P \geq P' \times \text{FS}$$

B) $n_1 \neq 1400 \text{ min}^{-1}$

Si dovrà effettuare la scelta come nel caso precedente però in base ad una potenza P_c corretta con i coefficienti riportati nelle tabelle relative ad ogni tipologia di riduttore verificando la relazione:

B) $n_1 \neq 1400 \text{ min}^{-1}$

Make the selection as described above but on the basis of power P_c corrected by the coefficients reported in the tables. The following equation should be checked out:

B) $n_1 \neq 1400 \text{ min}^{-1}$

Die Wahl wird wie im obigen Fall ausgeführt, allerdings auf der Basis einer Leistung P_c , die mit den Koeffizienten korrigiert wurde. Dabei ist das folgende Verhältnis zu überprüfen:

$$P_c \geq P' \times \text{FS}$$

Scelta del motoriduttore

C) $n_1 = 1400 \text{ min}^{-1}$ e $\text{FS} = 1$

Si cercherà nelle tabelle della prestazioni dei motoriduttori un gruppo la cui potenza P_1 corrisponda alla P' calcolata.

D) $n_1 \neq 1400 \text{ min}^{-1}$ o se il fattore $\text{FS} \neq 1$

La scelta dovrà essere effettuata come al punto A) verificando che la grandezza del motore da installare sia compatibile con quelle ammesse dal riduttore (IEC); ovviamente la potenza installata dovrà corrispondere al valore P' richiesto.

Selecting a gearmotor

C) $n_1 = 1400 \text{ min}^{-1}$ and $\text{FS} = 1$

Consult the gear motor efficiency table and select a group having power P_1 corresponding to calculated P' .

D) $n_1 \neq 1400 \text{ min}^{-1}$ or $\text{FS} \neq 1$

Follow the instructions at point A), checking that the size of the motor to be installed is compatible with the gear unit (IEC); obviously, installed power must correspond to the required P' value.

Wahl des Getriebemotors

C) $n_1 = 1400 \text{ min}^{-1}$ und $\text{FS} = 1$

In den Leistungstabellen der Getriebemotoren sucht man eine Baugruppe, deren Leistung P_1 der berechneten Leistung P' entspricht.

D) $n_1 \neq 1400 \text{ min}^{-1}$ oder $\text{FS} \neq 1$

Die Auswahl wird wie unter A) getroffen, wobei zu überprüfen ist, ob die Größe des zu installierenden Motors mit dem Untersetzungsgetriebe kompatibel ist (IEC); selbstverständlich muß die Einbauleistung dem erforderlichen Wert P' entsprechen.

1.4 Carichi radiali e assiali (N)

Le trasmissioni effettuate tramite pignoni per catena, ruote dentate o pulegge generano delle forze radiali (F_R) sugli alberi dei riduttori. L'entità di tali forze può essere calcolata con la formula:

1.4 Radial and axial loads (N)

Transmissions implemented by means of chain pinions, wheels or pulleys generate radial forces (F_R) on the gear unit shafts. The entity of these forces may be calculated using the following formula:

1.4 Radial- und Axialbelastungen (N)

Antriebe mit Kettenritzel, Zahnrädern oder Riemscheiben erzeugen radiale Kräfte (F_R) an den Wellen der Untersetzungsgetriebe. Das Ausmaß dieser Kräfte kann nach folgender Formel berechnet werden:

$$F_R = \frac{K_R \cdot T}{d} \text{ [N]}$$

dove:

T = Momento torcente [Nm]
d = Diametro pignone o puleggia [mm]

K_R = 2000 per pignone per catena
= 2500 per ruote dentate
= 3000 per puleggia con cinghie a V

where:

T = torque [Nm]
d = pinion or pulley diameter [mm]

K_R = 2000 for chain pinion
= 2500 for wheel
= 3000 for V-belt pulley

dabei ist:

T = Drehmoment [Nm]
d = Kettenritzel- bzw. Riemscheiben durchmesser [mm]

K_R = 2000 bei Kettenritzel
= 2500 bei Zahnrad
= 3000 bei Riemscheibe mit Keilriemen

I valori dei carichi radiali e assiali generati dall'applicazione debbono essere sempre minori o uguali a quelli ammissibili indicati nelle tabelle.

The values of the radial and axial loads generated by the application must always be lower than or equal to the admissible values reported in the tables.

Die Werte der Radial- und Axialbelastungen, die durch die Anwendung hervorgerufen werden, dürfen nicht über den in den Tabellen angegebenen zulässigen Werten liegen.

$$F_R \geq Fr_2$$

Verifiche

Verificare che i carichi radiali agenti sugli alberi rientrino nei valori ammissibili riportati nelle relative tabelle.

Tali valori (F_{R2}) si riferiscono a carichi che agiscono a metà sporgenza dell'albero, per cui se il punto di applicazione è diverso, è necessario effettuare il calcolo dei nuovi valori ammissibili alla distanza (y) desiderata.

Analogamente a quanto precisato sopra, anche i carichi assiali dovranno essere oggetto di verifica confrontandoli con i valori delle relative tabelle.

Sovraccarichi

Durante il normale funzionamento del riduttore è ammesso un sovraccarico istantaneo di emergenza pari al 100% della coppia indicata T_2 .

Se si temono sovraccarichi frequenti o superiori è indispensabile prevedere degli opportuni dispositivi per la limitazione della coppia.

Ingranaggi

Il calcolo a durata ed a fatica degli ingranaggi viene eseguito secondo la norma ISO 6336 e ISO 10300, considerando l'impiego di olio sintetico.

Check-list

Check that the radial loads on the shafts fall within to the admissible values reported in the relative tables.

Reported values (F_{R2}) refer to loads which affect the shaft at the half-way point of its projection; if the point of application is different, it is necessary to calculate the new admissible values at the desired distance (y).

In keeping with the above guidelines, axial loads should also be checked against the values reported in the relative tables.

Overloads

An emergency momentary overload up to 100% of T_2 torque is allowed during standard operation of the gearbox.

Should frequent or higher overloads be expected, it is necessary to install torque limiting devices.

Gears

Life and fatigue of the gears are calculated in compliance with ISO 6336 and ISO 10300. Calculations refer to utilization of synthetic oil

Überprüfungen

Es ist zu ueberpruefen, ob die, dass die auf die Wellen wirkenden Radiallasten unter den in der Tabellen angegebenen zulässigen Werten fallen.

Werte beziehen sich auf Lasten, die in der F_{R2} Mitte der herausragenden Welle wirken; bei verschiedenem Ansatzpunkt ist es daher erforderlich, die neuen, beim gewünschten Abstand (y) zulässigen Werte zu berechnen.

Ähnlich wie oben, müssen auch Axialbelastungen überprüft werden, indem man sie mit den Werten der jeweiligen Tabellen vergleicht.

Überbelastungen

Eine augenblickliche Notfall-Überbelastung zu 100% des T_2 Drehmoments darf während Getriebestandardbetrieb eintreten.

Falls häufige und höhere Überlastungen erwartet werden, sind die entsprechenden Vorrichtungen zur Begrenzung des Drehmoments anzubringen.

Räderwerk

Dauer und Belastung werden gemäß ISO 6336 und ISO 10300 berechnet. Dabei wird die Anwendung von synthetischem Öl berücksichtigt

1.5 Potenza Termica

Nelle tabelle riportate nelle sezioni relative ad ogni tipologia di riduttore sono indicati i valori della potenza termica nominale P_{t0} (kW). Tale valore rappresenta la potenza massima applicabile all'entrata del riduttore, in servizio continuo a temperatura ambiente di 30°C, così che la temperatura dell'olio non oltrepassi il valore di 95°C, valore massimo ammesso nel caso di prodotti standard.

Il valore di P_{t0} non deve essere preso in considerazione se il funzionamento è continuo per un massimo di 1.5 ore seguito da pause di durata sufficiente (circa 1 – 2 ore) a ristabilire nel riduttore la temperatura ambiente.

I valori di P_{t0} devono essere corretti tramite i seguenti coefficienti, così da considerare le reali condizioni di funzionamento, ottenendo i valori di potenza termica corretta P_{tc} .

1.5 Thermal power

The different sections dedicated to each type of gearbox contain tables reporting the values of rated thermal power P_{t0} (kW). Reported values correspond to the maximum admissible power at gearbox input, on continuous duty and with ambient temperature of 30°C, so that oil temperature does not exceed 95°C, which is the max. admissible value for standard products.

P_{t0} value should not be taken into account in case of continuous duty for max. 1.5 hours followed by pauses which are long enough to bring the gearbox back to ambient temperature (roughly 1 – 2 hours).

In order to comply with the actual operating conditions, P_{t0} values should be corrected with the following coefficients, thus obtaining the values of corrected thermal power P_{tc} .

1.5 Thermische Leistung

Für jeden Getriebetyp gibt es Tabellen, die die Nennwerte der thermischen Leistung P_{t0} (kW) angeben. Die angegebenen Werte stellen die max. anwendbare Antriebsleistung der Getriebe im Dauerbetrieb mit einer Umgebungstemperatur von max. 30°C dar, sodass die Öltemperatur unter 95°C bleibt (max. Wert für Standardprodukte).

P_{t0} Wert darf nicht betrachtet werden, falls Dauerbetrieb max. 1.5 Stunden dauert und von Stillstand gefolgt wird, der lang genug ist, damit das Getriebe zur Umgebungstemperatur zurück kommt. (ungefähr 1 – 2 Stunden).

P_{t0} Werte sollen durch die folgenden Koeffizienten verbessert werden. Damit die realen Betriebsbedingungen wirklich in Betracht gezogen werden. Mit der folgenden Formel erhält man die Werte der korrekten thermischen Leistung P_{tc} .

$$P_{tc} = P_{t0} \cdot ft \cdot fv \cdot fu \quad (\text{kW})$$

Dove:

ft = coefficiente di temperatura (v. tab. 3)

Where:

ft = temperature coefficient (see table 3)

Dabei ist:

ft = Temperaturkoeffizient (siehe Tabelle 3)

Tab. 3

Tc (°C)	0	5	10	15	20	25	30	35	40	45	50
ft	1.46	1.38	1.31	1.23	1.15	1.1	1	0.92	0.85	0.77	0.69

(Dove Tc (°C) è la temperatura ambiente)

(Tc (°C) is the ambient temperature)

(Tc (°C) ist die Umgebungstemperatur)

fv = coefficiente di ventilazione

- fv= 1.45 con ventilazione forzata efficace con ventola dedicata
- fv= 1.25 con ventilazione forzata secondaria ad altri dispositivi (pulegge, ventole motore, ecc.)
- fv= 1 refrigerazione naturale (situazione standard)
- fv= 0.5 in ambiente chiuso e ristretto (carter)

fv = cooling coefficient

- fv= 1.45 forced cooling with specific fan
- fv= 1.25 forced cooling secondary to other devices (pulleys, motor fans, etc)
- fv= 1 natural cooling (standard)
- fv= 0.5 in a closed and narrow environment

fv = Luftkühlungskoeffizient

- fv= 1.45 Drucklüftung mit Sonderlüfterrad
- fv= 1.25 Drucklüftung nebensächlich zu anderen Vorrichtungen (Scheiben, Motorlüfterräder, usw.)
- fv= 1 natürliche Lüftung (Standard)
- fv= 0.5 in engem und geschlossenem Raum

fu = coefficiente di utilizzo (v. tab. 4)

fu = utilization coefficient (see table 4)

fu = Verwendungskoeffizient (siehe Tabelle 4)

Tab. 4

Dt (min)	10	20	30	40	50	60
fu	1.6	1.35	1.2	1.1	1.05	1

Dove Dt sono i minuti di funzionamento in un'ora

Dt is minutes of operation per hour

Dt steht für Betriebsminuten pro Stunde

1.6 Lubrificazione

I cuscinetti dell'albero veloce vengono sempre lubrificati con grasso a base sintetica compatibile con l'uso alimentare. Il grasso utilizzato è il FUCHS CASSIDA GREASE HTS2; altri cuscinetti vengono lubrificati solo se la posizione di montaggio non ne garantisce la corretta lubrificazione.

Una scelta oculata del tipo di lubrificante, in funzione delle condizioni operative e ambientali, consente ai riduttori di raggiungere le prestazioni ottimali.

Le prestazioni dei riduttori indicate nelle tabelle dei dati tecnici sono state calcolate considerando l'impiego di olio sintetico alimentare: OLIO FUCHS CASSIDA FLUID 150 per GHA; OLIO FUCHS CASSIDA FLUID 320 per GK, GT, GX.

1.7 Installazione

Montare il riduttore in modo tale da eliminare qualsiasi vibrazione.

Curare particolarmente l'allineamento del riduttore con il motore e la macchina da comandare interponendo dove è possibile giunti elastici od autoallineanti.

Quando il riduttore è sottoposto a sovraccarichi prolungati, urti o pericoli di bloccaggio, installare salvamotori, limitatori di coppia, giunti idraulici od altri dispositivi similari.

Fare attenzione a non superare i valori consentiti di carico radiale ed assiale che agiscono sugli alberi veloce e lento.

Assicurarsi che gli organi da montare sui riduttori siano lavorati con tolleranza **ALBERO ISO h6 FORO ISO H7**.

Prima di effettuare il montaggio pulire e lubrificare le superfici al fine di evitare il pericolo di grippaggio e l'ossidazione da contatto.

Il montaggio va effettuato con l'ausilio di tiranti ed estrattori utilizzando il foro filettato posto in testa alle estremità degli alberi.

Tutti i riduttori e motoriduttori citati nel presente manuale sono destinati ad un impiego industriale con temperatura ambiente da -20°C a +40°C ad una altitudine max di 1000 m slm.

Per tutte le altre avvertenze consultare il manuale di "uso e manutenzione" scaricabile dal sito www.tramec.it

1.6 Lubrication

The bearings mounted on the input shaft are supplied with FUCHS CASSIDA GREASE HTS2, synthetic base and suitable for the food industry. The other bearings are lubricated only if the mounting position does not guarantee proper lubrication.

An optimized selection of the type of lubricant, depending on operating and environmental conditions, will allow the gearboxes to achieve excellent performances.

Performance data, as shown in the specification tables, refer to the use of synthetic oil for food industry: FUCHS CASSIDA FLUID 150 LUBRICANT for GHA; FUCHS CASSIDA FLUID 320 LUBRICANT for GK, GT, GX.

1.7 Installation

Install the gearbox so that any vibration is eliminated.

Take special care with the alignment between the gear units, the motor and the driven machine, fitting flexible or self adjusting couplings wherever possible.

If the gearbox is subject to prolonged overloads, shocks or possible jamming, fit overload cutouts, torque limiters, hydraulic couplings or other similar devices.

Do not exceed allowed radial and axial loads on the input and output shafts.

*Ensure that the components to be fitted on the gear units are machined with tolerance **SHAFT ISO h6 HOLE ISO H7**.*

Before assembling, clean and lubricate the surfaces to prevent seizure and contact oxidation.

Assembly is to be carried out with the aid of tie-rods and extractors, using the threaded hole at the shaft ends.

All reducers and gear motors mentioned in this catalog are intended for industrial use and operation at a ambient temperature between -20°C and +40°C, at an altitude of max. 1000 m above sea level.

For all other instructions check the "Use and Maintenance Manual" which can be downloaded from our web site www.tramec.it

1.6 Schmierung

Die Lager auf der Antriebswelle werden mit FUCHS CASSIDA GREASE HTS2 Fett (synthetisch) geschmiert, geeignet für die Lebensmittelindustrie.

Sollte die Einbaulage keine korrekte Schmierung der restlichen Lager gewährleisten, so werden auch diese mit Schmiermittelfüllung ausgestattet.

Eine den Betriebs- und Umgebungsbedingungen angepasste Schmiermittelauswahl gewährleistet eine einwandfreie Funktion der Getriebe.

Die in den Tabellen angegebenen technischen Daten beziehen sich auf die Schmierung mit Lebensmittelöl FUCHS CASSIDA FLUID 150 für GHA; FUCHS CASSIDA FLUID 320 für GK, GT, GX.

1.7 Einbau

Das Getriebe ist so zu montieren, daß Schwingungen ausgeschaltet werden.

Insbesondere ist auf die Fluchtung des Getriebes zum Motor und zur Maschine zu achten, wo möglich sind elastische oder selbstfluchtende Kupplungen anzubringen.

Wenn das Getriebe anhaltenden Überlasten, Schlägen oder Blockierungsgefahr ausgesetzt ist, sind Motorschalter, Drehmomentbegrenzer, hydraulische Kupplungen oder ähnliche Vorrichtungen anzubringen.

Achten sie darauf, dass die zulässigen Radial- und Axialbelastungen an Antriebs- und Abtriebswelle nicht überschritten werden.

Achten Sie darauf, dass die am Getriebe montierten Elemente mit folgenden Toleranzen bearbeitet sind: **WELLE ISO h6, BOHRUNG ISO H7**.

Vor der Montage sind die Flächen zu reinigen und zu schmieren, um Festfressen bzw. Kontaktoxidation zu vermeiden.

Die Montage erfolgt mit Hilfe von Zugstangen und Ausziehvorrichtungen unter Verwendung der Gewindebohrung vorn an den Wellenenden.

Alle im vorliegenden Katalog angegebenen Getriebe und Getriebemotoren sind für industriellen Einsatz in einer Umgebungstemperatur von -20°C bis +40°C und in einer max. Höhe von 1000 m über dem Meeresspiegel vorgesehen.

Für weitere Anweisungen laden Sie die "Betriebs- und Instandhaltungsanweisung" aus unsere Webseite www.tramec.it herunter.

1.8 **Rodaggio**

Si consiglia di incrementare gradualmente nel tempo la potenza trasmessa oppure limitare il momento torcente resistente della macchina da comandare per le prime ore di funzionamento.

1.9 **Manutenzione**

Controllare periodicamente il livello del lubrificante ed effettuare il cambio dopo 12500 ore di funzionamento.

Quando il riduttore resta per lungo tempo inattivo in un ambiente con una elevata percentuale di umidità si consiglia di riempirlo completamente di olio.

Naturalmente al momento della successiva messa in funzione sarà necessario ripristinare il livello del lubrificante.

1.8 **Running-in**

Increase the transmitted power gradually or limit the resistant torque of the driven machine for the first few operating hours.

1.9 **Maintenance**

Check the lubricant level regularly and change after 12500 operating hours.

When the gearbox is left unused in a highly humid environment fill it completely with oil.

Importantly the oil must be returned to the operating level before the unit is used again.

1.8 **Einfahren**

Es ist ratsam, die Leistung nur allmählich zu steigern oder das Widerstandsdrehmoment der Maschine in den ersten Betriebsstunden zu begrenzen.

1.9 **Wartung**

Von Zeit zu Zeit ist der Ölstand zu prüfen, alle 12500 Betriebsstunden sollte ein Ölwechsel stattfinden.

Wenn das Getriebe lange Zeit in einem Raum mit hoher Luftfeuchtigkeit stillliegt, ist es ratsam, es ganz mit Öl zu füllen.

Wird es danach wieder in Betrieb genommen, so ist natürlich vorher der richtige Ölstand wiederherzustellen.

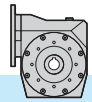

2.0	RIDUTTORI A VITE SENZA FINE GHA	GHA WORM GEARBOXES	SCHNECKENGETRIEBE GHA	
2.1	Caratteristiche	<i>Characteristics</i>	Merkmale	18
2.2	Designazione	<i>Designation</i>	Bezeichnung	19
2.3	Rendimento	<i>Efficiency</i>	Wirkungsgrad	20
2.4	Irreversibilità	<i>Irreversibility</i>	Selbsthemmung	20
2.5	Gioco angolare	<i>Backlash</i>	Winkelspiel	21
2.6	Carichi radiali	<i>Radial load</i>	Radialbelastungen	22
2.7	Senso di rotazione	<i>Direction of rotation</i>	Drehrichtung	22
2.8	Lubrificazione e posizioni di montaggio	<i>Lubrication and mounting position</i>	Schmierung und Einbaulage	23
2.9	Posizione morsettiera	<i>Terminal board position</i>	Lage des Klemmbrett	23
2.10	Dati tecnici	<i>Technical data</i>	Technische Daten	24
2.11	Momenti d'inerzia	<i>Moment of inertia</i>	Trägheitsmoment	26
2.12	Dimensioni	<i>Dimensions</i>	Abmessungen	28
2.13	Lista parti di ricambio	<i>Spare parts list</i>	Ersatzteilliste	31

GHA - PREMIUM

La serie PREMIUM rappresenta la serie di punta all'interno della gamma di riduttori GHA, in virtù delle speciali caratteristiche NANOTECCNOLOGICHE potenziate del rivestimento.

Il trattamento GHA potenziato e il particolare design esterno a superficie liscia rendono i riduttori della serie PREMIUM la soluzione ideale per un'ampia gamma di applicazioni in ambienti sensibili nei settori ALIMENTARE, FARMACEUTICO e MARINO.

Il riduttore non è adatto al contatto con gli alimenti.

GHA - PREMIUM

The PREMIUM series represents the flagship series within the range of GHA reducers, thanks to the special enhanced NANOTECHNOLOGICAL characteristics of the coating.

The enhanced GHA treatment and the particular external design with its smooth surface make the PREMIUM series reducers the ideal solution for a wide range of applications in sensitive environments in the FOOD, PHARMACEUTICAL and MARINE sectors.

The reducer is not suitable for contact with food.

GHA - PREMIUM

Die Serie PREMIUM stellt die Spitzenbaureihe der GHA-Getriebe dar, da sie über spezielle, verstärkte NANOTECHNOLOGISCHE Merkmale an der Beschichtung verfügt.

Dank der verstärkten GHA-Behandlung und dem besonderen äußeren Design mit glatter Außenoberfläche stellen die Getriebe der Serie PREMIUM die ideale Lösung für eine große Anzahl von Anwendungen in empfindlichen Bereichen in der LEBENSMITTEL-, PHARMA- UND SCHIFFFAHRTSBRANCHE dar.

Das Getriebe ist nicht für den Kontakt mit Lebensmitteln geeignet.

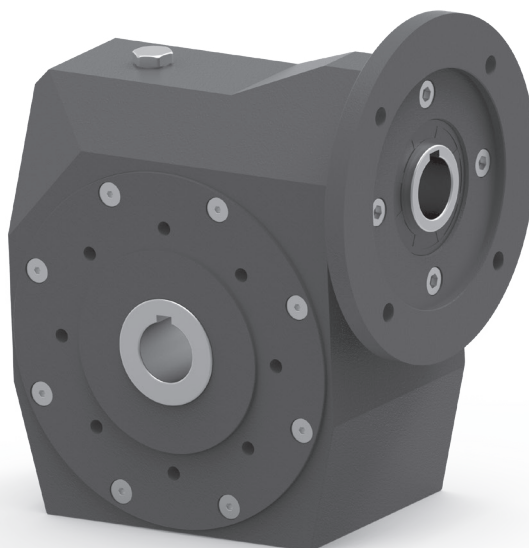

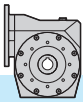

2.1 Caratteristiche

- I riduttori della serie a vite senza fine GHA si presentano estremamente leggeri grazie alla forma compatta della carcassa in alluminio per tutte le grandezze.
- La serie GHA è disponibile esclusivamente nella versione predisposta per attacco motore (PAM) e non con albero entrata maschio.
- La vite senza fine è in acciaio legato cementato-temprato ed è rettificata.
- La corona ha il mozzo in acciaio INOX AISI 316 e l'anello dentato in bronzo GCuSn12.
- Le carcasce e flange in alluminio sono sabbiato e trattate con tecnologia G.H.A. ®
- Viene fornito l'albero uscita cavo di serie ed esiste la disponibilità della seconda entrata.

2.1 Characteristics

- *The GHA worm gearboxes are extremely light thanks to the compact shape of the housing which is in die-cast aluminum for all sizes.*
- *The GHA series is available for motor mounting version (PAM) only and not with the male input shaft.*
- *The worm shaft is made of hardened-bonded steel and ground.*
- *The wheel has an AISI 316 stainless steel hub with a toothed ring made in bronze GcuSn12.*
- *Aluminum housings and flanges are sandblasted and treated in accordance with G.H.A. ® technology.*
- *The hollow output shaft is supplied as standard. A broad range of accessories is available: second input.*

2.1 Merkmale

- Die Schneckengetriebe der Serie GHA sind, dank der kompakten Form des Gehäuses, sehr leicht. Das Gehäuse aller Baugrößen ist aus Druckgussaluminium gefertigt.
- Die Serie GK ist nur mit Motoranbau (IEC) Version und nicht mit einer freien Antriebswelle verfügbar.
- Die Schneckenwelle ist aus einsatzgehärtetem, abgeschrecktem und daraufhin geschliffenem Legierungsstahl
- Das Schneckenrad besteht aus einer Nabe aus Edelstahl AISI 316 und einer Bronze- Verzahnung GCuSn12.
- Die Aluminiumgehäuse und Flansche sind sandgestrahlt und mit G.H.A. ® - Technik behandelt.
- Die Hohlwelle gehört zur serienmäßigen Ausstattung. Eine breite Auswahl an Zubehör ist erhältlich: Zweiteingang

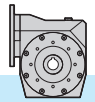

2.2 Designazione

2.2 Designation

2.2 Bezeichnung

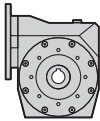
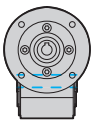
Riduttore Gearbox Getriebe	Grandezza Size Größe	Rapporto rid. Ratio Untersetzung	Predispos. att. mot. Motor coupling Motoranschluss	Posizione di mont. Mounting position Einbaulage	Versione Version Ausführung	Albero uscita cavo Hollow output shaft Abtriebshohlwelle
GHA	50	10/1	P.A.M	B3	PP	H25
	30 40 50 63 75	5 7.5 10 15 20 25 30 40 50 65 80 100	56 B14 63 B14 71 B14 80 B14 90 B14 100 B14 112 B14	B3, B6 B7, B8 V5, V6	PP CC PD PS	 H..

GHA...PP

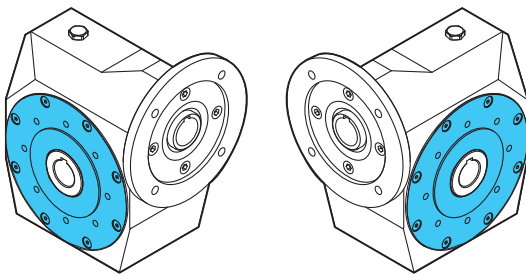

GHA...CC

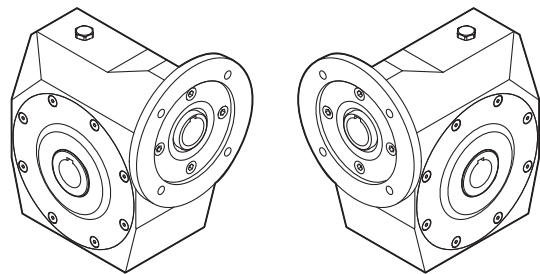

GHA...PD

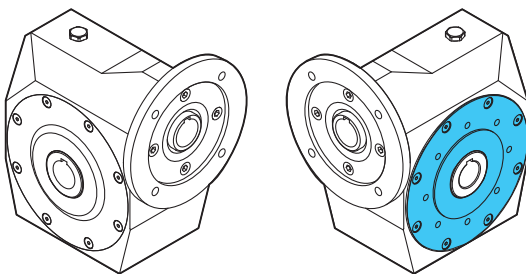

GHA...PS

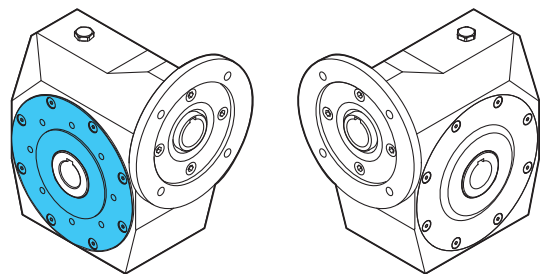

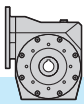

2.3 Rendimento

Rd - È il rendimento dinamico, definito come rapporto tra la potenza in uscita P_2 e quella in entrata P_1 . Dipende principalmente dalla velocità di strisciamento, dal tipo di lubrificante e dall'angolo d'elica. I valori indicati nelle tabelle sono validi se si applica la corrispondente coppia in uscita. In fase di rodaggio, circa le prime 300 ore di funzionamento sotto carico, il valore deve essere considerato inferiore del 30% rispetto a quello indicato in tabella.

Rs - È il rendimento statico che si ha al momento dell'avviamento del riduttore e varia in base al rapporto di riduzione. Risulta importante, per una corretta valutazione del riduttore da impiegare, nelle applicazioni in cui non si raggiungono mai le condizioni di regime come nei funzionamenti intermittenti. Analogamente al caso dinamico, anche il rendimento statico durante il rodaggio risulta inferiore del 30% rispetto al valore indicato in tabella.

2.3 Efficiency

Rd - dynamic efficiency, defined as the ratio between P_2 output power and P_1 input power. It mainly depends on the slipping speed, the type of lubricant and the lead angle. The values reported in the table are valid when the corresponding output torque is applied. During the first 300 operating hours under load, the value to be considered is 30% lower than that reported in the table.

Rs - static efficiency at gearbox start-up; it changes depending on the reduction ratio. Rs value is important for selecting the right gearbox for applications where a steady state is never achieved, as for intermittent duty applications. Same as dynamic efficiency, static efficiency too during the running-in period will be 30% lower than the value reported in the table.

2.3 Wirkungsgrad

Rd - dynamischer Wirkungsgrad, ist das Verhältnis zwischen P_2 Abtriebsleistung und P_1 Antriebsleistung. Rd Wert wird durch Gleitgeschwindigkeit, Art des Schmiermittels und Steigungswinkel beeinflusst. Die Tabellen zeigen die Werte die gültig sind wenn das entsprechende Abtriebsdrehmoment gegeben ist. Während der Einlaufzeit in den ersten 300 Betriebsstunden unter Belastung, ist dieser Wert 30% niedriger als der in der Leistungstabelle angegebenen Wert.

Rs - statischer Wirkungsgrad beim Getriebebestart und in Abhängigkeit zur Unterersetzung. Der Wert Rs ist wichtig für die Auswahl des richtigen Getriebes für Anwendungen wo ein stetiger Betrieb nicht auftritt, wie bei Anwendungen mit Aussetzbetrieb. Der statischer Wirkungsgrad auch während der Einlaufzeit wird 30% niedriger als der in der Tabelle angegebenen Wert.

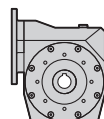

GHA	Rs											
	5	7.5	10	15	20	25	30	40	50	65	80	100
30	0.70	0.67	0.62	0.55	0.47	0.43	0.39	0.30	0.27	0.25	0.22	0.21
40	0.69	0.67	0.63	0.55	0.52	0.45	0.40	0.35	0.29	0.26	0.25	0.23
50	0.69	0.68	0.65	0.58	0.53	0.47	0.41	0.37	0.32	0.28	0.25	0.23
63	0.70	0.68	0.65	0.57	0.55	0.50	0.47	0.38	0.33	0.29	0.28	0.23
75	/	0.68	0.65	0.58	0.55	0.51	0.43	0.39	0.35	0.31	0.28	0.24

2.4 Irreversibilità

Nelle applicazioni dove è necessario evitare la trasmissione del moto retrogrado o sostenere il carico, in assenza di alimentazione elettrica, è consigliabile adottare freni esterni.

Nei riduttori a vite senza fine emerge questa caratteristica naturale, denominata grado di irreversibilità, che cresce con l'aumentare del rapporto di riduzione in quanto strettamente legata al relativo rendimento.

Per ottenere alti gradi di irreversibilità occorre quindi adottare i rapporti di riduzione più elevati, senza dimenticare che, il rendimento, tende a crescere durante le prime 500 ore di funzionamento per poi stabilizzarsi sui valori riportati a catalogo.

Irreversibilità statica

Condizione di impedimento alla rotazione comandata dall'albero lento senza escludere possibili ritorni lenti nel caso in cui il carico sia sottoposto a vibrazioni.

Rs < 0.45 si ha irreversibilità
Rs = 0.45 ÷ 0.55 irreversibilità incerta
Rs > 0.55 si ha reversibilità

2.4 Irreversibility

The use of external brakes is advised in case of applications where backwards motion must be hindered and the load must be held should the feed be cut off.

Some worm gearboxes feature natural irreversibility. The higher the ratio, the higher is the irreversibility, since it is strictly dependent on the relative efficiency.

In order to achieve high irreversibility it is therefore necessary to select higher efficiency reduction ratios not to forget that the efficiency is growing during the first 500 hours life until it stabilizes to the values mentioned in the catalogue.

Static irreversibility

Static irreversibility occurs when the rotation controlled by the output shaft is hindered; possible slow returns cannot be excluded should the load be subject to vibrations.

Rs < 0.45 provides irreversibility
Rs = 0.45 ÷ 0.55 irreversibility is uncertain
Rs > 0.55 reversibility is possible

2.4 Selbsthemmung

Aussenbremsen sind bei Anwendungen zu benutzen, bei denen Rückbewegung vermeiden werden muss oder die Last auch im Falle von Fehlen an Speisung gehalten werden muss.

Einige Schneckengetriebe sind selbsthemmend. Je höher die Unterersetzung ist, desto höher ist die Selbsthemmung, da diese stark vom jeweiligen Wirkungsgrad abhängig ist. Um eine höhere Selbsthemmung zu erreichen, wählen Sie bitte höhere Untersetzungsverhältnisse.

Bitte beachten Sie, dass der Wirkungsgrad der Getriebe in den ersten 500 Betriebsstunden ansteigt und sich erst anschließend auf die im Katalog angegebenen Werte stabilisiert.

Statische Selbsthemmung

Statische Selbsthemmung liegt vor, wenn die von Abtriebswelle gesteuerten Drehung gehindert wird. Langsamer Rücklauf ist möglich, falls die Last Schwingungen ausgesetzt wird.

Rs < 0.45 es liegt Selbsthemmung vor
Rs = 0.45 ÷ 0.55 ungewisse Selbsthemmung
Rs > 0.55 es liegt Reversibilität vor

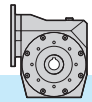

Irreversibilità dinamica

Condizione di arresto e quindi di sostegno del carico nel momento in cui cessa l'azione di comando. La condizione è più difficile da ottenere in quanto viene influenzata dal rendimento dinamico, dalla velocità di rotazione, da eventuali vibrazioni che il carico può generare e dalla direzione del movimento rispetto al carico.

Quest'ultima condizione è molto evidente nei sollevamenti: un carico in salita, cessando l'azione di comando, deve arrestarsi e quindi assumere velocità zero (rendimento statico) prima di invertire il moto e cadere per gravità.

Un carico in discesa tende invece a proseguire nel suo moto ostacolato, nella caduta, dal solo rendimento dinamico.

Rd < 0.45 si ha irreversibilità
Rd = 0.45 ÷ 0.55 irreversibilità incerta
Rd > 0.55 si ha reversibilità

Dynamic irreversibility

Dynamic irreversibility is characterized by stillstand and hold of the load when the drive stops. It is more difficult to achieve this condition because it is influenced by dynamic efficiency, speed of rotation and possible vibrations generated by the motion direction with regard to the load.

This last condition is much more evident during the lifting : if the drive stops during the lifting of the load this has to come to a speed equals to zero (static irreversibility) before the reversal of motion rotation and its drop for gravity.

On the contrary the load during its descent gets its motion obstructed by its dynamic efficiency.

Rd < 0.45 provides irreversibility
Rd = 0.45 ÷ 0.55 irreversibility is uncertain
Rd > 0.55 reversibility is possible

Dynamische Selbsthemmung

Stillstand und Stütze der Last beim Aussetzen der Steuerung. Diese Bedingung ist schwieriger zu erreichen, da sie vom dynamischen Wirkungsgrad, der Drehzahl und von der Last verursachten möglichen Vibrationen abhängig ist

Dieser letzte Fall kommt bei Hubanwendungen stark zu tragen. Wenn der Antrieb während dem Hub stoppt, muss die Last eine Geschwindigkeit von annähernd null erreichen (statische Irreversibilität), bevor die Rotation sich umkehrt und die Last durch die Gravitation nach unten fährt. Dem entgegengesetzt bekommt die Last durch die Abwärtsbewegung Ihre dynamische Effizienz.

Rd < 0.45 es liegt Selbsthemmung vor
Rd = 0.45 ÷ 0.55 ungewisse Selbsthemmung
Rd > 0.55 es liegt Reversibilität vor

2.5 Gioco angolare

Gioco angolare standard

Misurato bloccando l'albero entrata, e ruotando l'albero uscita nelle due direzioni applicando la coppia strettamente necessaria a creare il contatto tra i denti degli ingranaggi, al massimo pari al 2% della coppia nominale (T_{2M}).

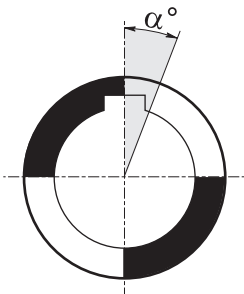

2.5 Backlash

Backlash

Angular backlash measured after having blocked the input shaft by rotating output shaft in both directions and applying the torque which is strictly necessary to create a contact between the teeth of the gears. The applied torque should be at most 2% of the max. torque (T_{2M}).

2.5 Winkelspiel

Winkelspiel

Nachdem die Antriebswelle blockiert worden ist, darf das Winkelspiel auf die Abtriebswelle bemessen werden. Dabei soll die Antriebswelle in beiden Richtungen gedreht werden und ein Drehmoment ausgeübt werden, das zur Entstehen eines Kontaktes zwischen den Zähnen genuegt. Das ausgeübte Drehmoment soll höchstens 2% des max. von Getrieben garantierten Drehmoment (T_{2M}) sein.

GHA					
i_n	30	40	50	63	75
	max	max	max	max	max
5	16'	13.5'	10.5'	10'	/
7.5	16'	13.5'	10.5'	10'	10'
10	16'	13.5'	10.5'	10'	10'
15	16'	13.5'	10.5'	10'	10'
20	14.5'	12'	9.5'	8.5'	8.5'
25	14.5'	12'	9.5'	8.5'	8.5'
30	14.5'	12'	8.5'	8.5'	8.5'
40	14.5'	12'	9.5'	8.5'	8.5'
50	14'	12'	9.5'	8.5'	8.5'
65	14'	12'	9'	8'	8'
80	13.5'	11.5'	9'	7.5'	7.5'
100	13'	11'	9'	7.5'	7.5'

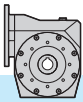

2.6 Carichi radiali

Carichi radiali Fr_2 e assiali Fa_2 sull'albero uscita [N]

Se il carico radiale sull'albero non è applicato a metà della sporgenza dell'albero, il valore del carico ammissibile deve essere valutato utilizzando la formula che si riferisce ad Fry_2 , in cui i valori di a, b e Fr_2 sono riportati nelle tabelle relative ai carichi radiali.

Nel caso di alberi bisporgenti il valore del carico applicabile a ciascuna estremità è uguale ai 2/3 del valore di tabella, purché i carichi applicati siano uguali di intensità e direzione ed agiscano nello stesso senso. Diversamente contattare il servizio tecnico.

I carichi radiali indicati nelle tabelle si intendono applicati a metà della sporgenza dell'albero e sono riferiti ai riduttori operanti con fattore di servizio 1.

2.6 Radial load

Fr_2 radial loads and Fa_2 axial loads on the output shaft [N]

Should the radial load affect the shaft not at the half-way point of its projection but at a different point, the value of the admissible load has to be calculated using the Fry_2 formula: a, b and Fr_2 values are reported in the radial load tables.

With regard to double-projecting shafts, the load applicable at each end is 2/3 of the value given in the table, on condition that the applied loads feature same intensity and direction and that they act in the same direction.

Otherwise please contact the technical department.

The radial loads indicated in the chart are considered to be applied at the half-way point of the shaft projection, and refer to gear units operating with service factor 1.

2.6 Radialbelastungen

Fr_2 Radialbelastungen und Fa_2 Axialbelastungen auf die Abtriebswelle [N]

Falls die Radialbelastungen nicht in dem Mittelpunkt der herausragenden Welle sondern in einem anderen Punkt wirken, soll die zulässige Belastung mit der Formel bezüglich Fry_2 kalkuliert werden: a, b und Fr_2 Werte sind aus der Tabelle der Radialbelastungen zu entnehmen.

Bei doppelseitigen Abtriebswellen ist die Belastung, die an jedem Ende anwendbar ist, 2/3 des in der Tabelle angegebenen Wertes unter der Bedingung, dass die Belastungen die selbe Stärke und Richtung aufweisen und dass sie in der selben Richtung wirken. Andernfalls muß mit dem technischen Büro Rücksprache gehalten werden.

Die Radialbelastungen, die in den Tabellen angegeben werden, gelten für Ansatzpunkte in der Mitte des herausragenden Wellenteils und für Getriebe mit Betriebsfaktor 1.

GHA											
$n_1=1400$ rpm		30		40		50		63		75	
i_n	n_2 [rpm]	a = 64.5 b = 47		a = 81.5 b = 58.5		a = 99 b = 70.5		a = 119.5 b = 90.5		a = 131 b = 97	
		Fr_2	Fa_2	Fr_2	Fa_2	Fr_2	Fa_2	Fr_2	Fa_2	Fr_2	Fa_2
5	280	600	120	750	150	900	180	1050	210	/	/
7.5	187	620	125	850	170	1050	210	1200	240	1500	300
10	140	680	140	950	190	1150	230	1350	270	1700	340
15	93	720	145	1000	200	1250	250	1500	300	1900	380
20	70	750	150	1100	220	1400	280	1650	330	2050	410
25	56	800	160	1200	240	1500	300	1850	370	2250	450
30	47	850	170	1250	250	1650	330	2000	400	2450	490
40	35	900	180	1350	270	1750	350	2150	430	2600	520
50	28	920	185	1450	290	1850	370	2300	460	2800	560
60	23	970	195	1550	310	2000	400	2500	500	3000	600
63	22	1000	200	1600	320	2100	420	2650	530	3200	640
80	17.5	1050	210	1700	340	2250	450	2800	560	3350	670
100	14	1100	220	1800	360	2350	470	2950	590	3550	710

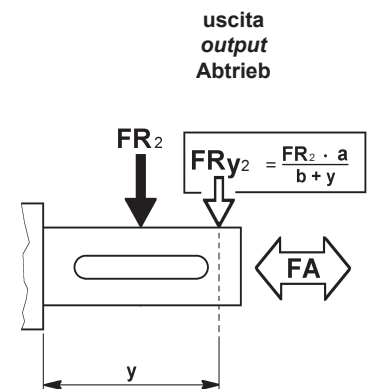

2.7 Senso di rotazione

2.7 Direction of rotation

2.7 Drehrichtung

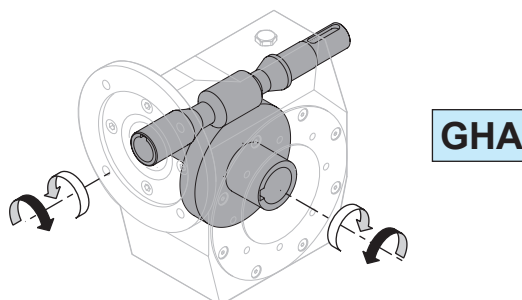

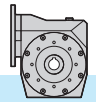

2.8 Lubrificazione

I riduttori a vite senza fine serie GHA sono forniti completi di lubrificante sintetico per uso alimentare: OLIO FUCHS CASSIDA FLUID 150.

Si raccomanda di precisare sempre, in fase di ordine, la posizione di montaggio desiderata.

Posizioni di montaggio

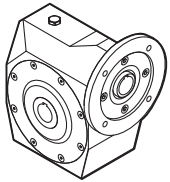

B3

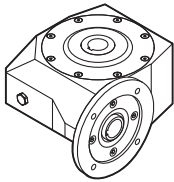

B6

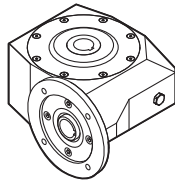

B7

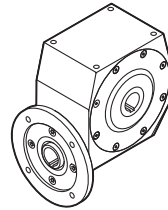

B8

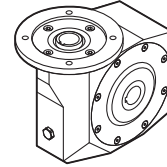

V5

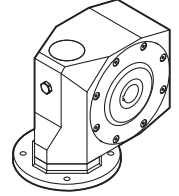

V6

E' presente un solo tappo di riempimento olio.

2.8 Lubrication

The GHA series worm gearboxes are supplied complete with synthetic lubricant for food use: FUCHS CASSIDA FLUID 150 OIL.

Mounting position always to be specified when ordering.

Mounting positions

2.8 Schmierung

Die Schneckengetriebe der Serie GHA werden mit synthetischem Lebensmittelöl FUCHS CASSIDA FLUID 150 geliefert.

Bei der Bestellung bitte immer die gewünschte Einbaulage angeben.

Einbaulagen

There is only one filling plug only.

Es gibt nur eine Einfüllschraube.

		Q.tà olio / Oil quantity / Schmiermittelmenge [lt]			
		Posizione di montaggio / Mounting position / Einbaulage			
		B3	B6 - B7	B8	V5 - V6
GHA	30	0.015	0.030	0.015	
	40	0.040	0.060	0.040	
	50	0.080	0.120	0.080	
	63	0.160	0.220	0.160	
	75	0.260	0.340	0.260	

2.9 Posizione morsettiera

2.9 Terminal board position

2.9 Lage der Klemmenkaste

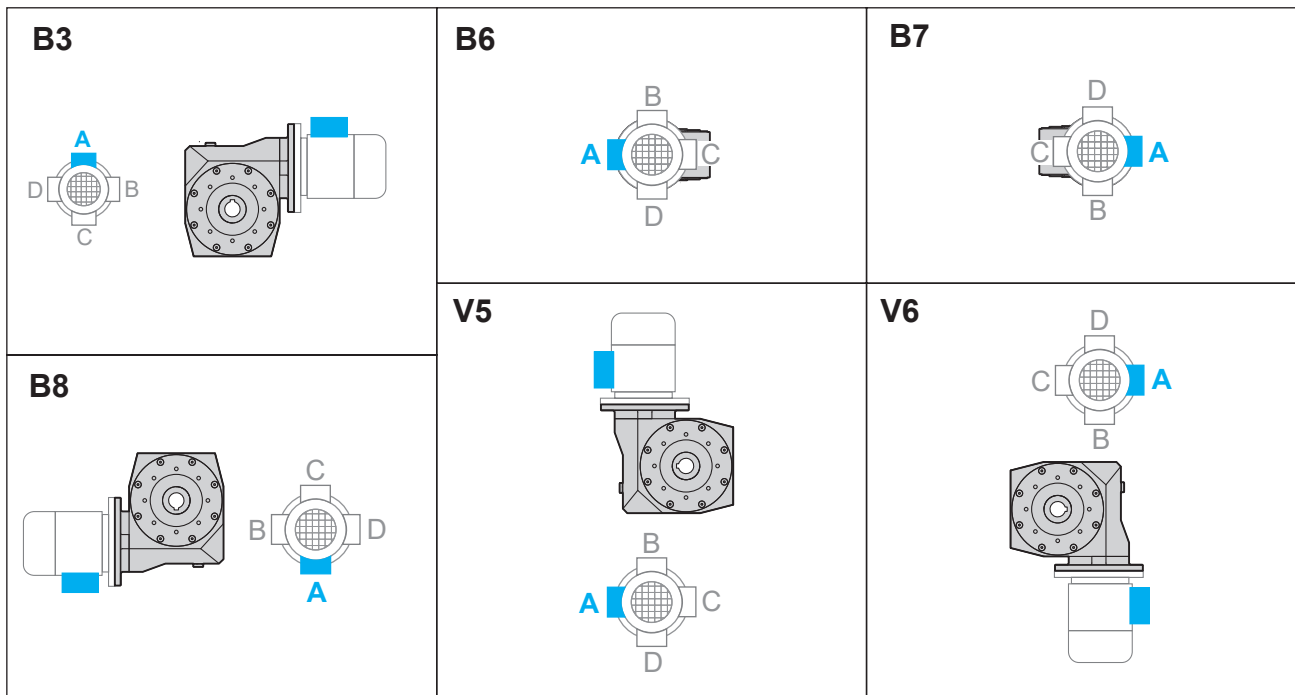

Specificare sempre in fase di ordinazione la posizione di montaggio e la forma costruttiva.

Mounting position always to be specified when ordering.

Bei der Bestellung immer die gewünschte Montageposition und Bauform angeben.

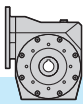

2.10 Dati tecnici

2.10 Technical data

2.10 Technische Daten

GHA 30	$n_1 = 1400$				MOTORI / MOTORS / ENGINE									
	i_n	n_2 [min ⁻¹]	Rd	P_{t0}	GHA CLASSIC				MHA PREMIUM					
					T_2 [Nm]	P_1 [kW]	IEC B14	FS'	T_2 [Nm]	P_1 [kW]	IEC B14	FS'		
Kg 1.4	5	280	0.87	0.40	6.5	0.22	63	2.9	5.3	0.18	63	3.6		
	7.5	187	0.84	0.40	9	0.22			2.2	7.7			0.18	2.7
	10	140	0.82	0.40	12	0.22			1.8	10			0.18	2.2
	15	93	0.77	0.30	17	0.22			1.3	14			0.18	1.6
	20	70	0.72	0.20	18	0.18			1.1	18			0.18	1.1
	25	56	0.69	0.20	21	0.18			1.0	21			0.18	1.0
	30	47	0.66	0.20	18	0.13	1.1	17	0.13	1.2				
	40	35	0.59	0.20	21	0.13	1.0	21	0.13	1.0				
	50	28	0.55	0.20	17	0.09	1.1	24	0.13	0.8				
	65	22	0.51	0.10	20	0.09	1.0	-	-	-	-			
80	18	0.48	0.10	16	0.06	1.0	-	-	-	-				
100	14	0.45	0.10	18	0.06	0.8	-	-	-	-				

GHA 40	$n_1 = 1400$				MOTORI / MOTORS / ENGINE									
	i_n	n_2 [min ⁻¹]	Rd	P_{t0}	GHA CLASSIC				MHA PREMIUM					
					T_2 [Nm]	P_1 [kW]	IEC B14	FS'	T_2 [Nm]	P_1 [kW]	IEC B14	FS'		
Kg 2.4	5	280	0.87	0.80	16.3	0.55	71	2.1	11	0.37	71	3.1		
	7.5	187	0.85	0.80	24	0.55			1.7	16			0.37	2.5
	10	140	0.83	0.70	31	0.55			1.3	21			0.37	2.0
	15	93	0.79	0.50	30	0.37			1.4	30			0.37	1.4
	20	70	0.76	0.50	38	0.37			1.0	38			0.37	1.1
	25	56	0.72	0.40	31	0.25			1.1	31			0.25	1.2
	30	47	0.68	0.40	35	0.25	1.2	35	0.25	1.2				
	40	35	0.64	0.30	38	0.22	1.0	31	0.18	1.2				
	50	28	0.59	0.30	36	0.18	1.1	36	0.18	1.1				
	65	22	0.54	0.20	31	0.13	1.1	30	0.13	1.2				
80	18	0.52	0.20	35	0.13	0.9	36	0.13	0.9					
100	14	0.49	0.20	43	0.13	0.6	43	0.13	0.6					

GHA 50	$n_1 = 1400$				MOTORI / MOTORS / ENGINE									
	i_n	n_2 [min ⁻¹]	Rd	P_{t0}	GHA CLASSIC				MHA PREMIUM					
					T_2 [Nm]	P_1 [kW]	IEC B14	FS'	T_2 [Nm]	P_1 [kW]	IEC B14	FS'		
Kg 4.0	5	280	0.87	1.2	26.7	0.9	80	2.3	22	0.75	80	2.8		
	7.5	187	0.86	1.2	40	0.9			1.8	33			0.75	2.1
	10	140	0.84	1.0	52	0.9			1.4	43			0.75	1.7
	15	93	0.80	0.80	74	0.9			1.0	62			0.75	1.2
	20	70	0.78	0.70	58	0.55			1.3	53			0.5	1.4
	25	56	0.74	0.60	47	0.37			1.4	63			0.5	1.0
	30	47	0.71	0.60	53	0.37	1.2	53	0.37	1.2				
	40	35	0.67	0.50	68	0.37	1.0	68	0.37	1.0				
	50	28	0.62	0.40	53	0.25	1.3	53	0.25	1.3				
	65	22	0.58	0.40	64	0.25	1.0	63	0.25	1.0				
80	18	0.54	0.40	71	0.25	0.8	52	0.18	1.1					
100	14	0.51	0.30	86	0.25	0.6	45	0.13	1.2					

* **ATTENZIONE:** la coppia massima utilizzabile [T_{2M}] deve essere calcolata utilizzando il fattore di servizio: $T_{2M} = T_2 \times FS'$

* **WARNING:** Maximum allowable torque [T_{2M}] must be calculated using the following service factor: $T_{2M} = T_2 \times FS'$

* **ACHTUNG:** das max. anwendbare Drehmoment [T_{2M}] muss mit folgendem Betriebsfaktor berechnet werden: $T_{2M} = T_2 \times FS'$

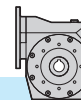

2.10 Dati tecnici

2.10 Technical data

2.10 Technische Daten

GHA 63	$n_1 = 1400$				MOTORI / MOTORS / ENGINE							
	i_n	n_2 [min ⁻¹]	Rd	P_{t0}	GHA CLASSIC				MHA PREMIUM			
					T_2 [Nm]	P_1 [kW]	IEC B14	FS'	T_2 [Nm]	P_1 [kW]	IEC B14	FS'
Kg 6.6	5	280	0.88	1.8	54	1.8	90	2.0	45	1.5	90	2.5
	7.5	187	0.87	1.8	80	1.8		1.5	67	1.5		1.8
	10	140	0.85	1.6	105	1.8		1.2	87	1.5		1.5
	15	93	0.81	1.2	125	1.5		1.1	125	1.5		1.1
	20	70	0.80	1.2	120	1.1		1.2	120	1.1		1.2
	25	56	0.77	1.0	118	0.9	1.0	98	0.75	1.2		
	30	47	0.73	0.90	134	0.9	1.1	111	0.75	1.3		
	40	35	0.69	0.80	142	0.75	1.1	141	0.75	1.1		
	50	28	0.65	0.70	122	0.55	1.0	111	0.5	80	1.1	
	65	22	0.61	0.60	145	0.55	0.8	98	0.37	1.2		
80	18	0.58	0.60	169	0.55	0.6	113	0.37	1.0			
100	14	0.53	0.50	198	0.55	0.5	90	0.25	1.1			

GHA 75	$n_1 = 1400$				MOTORI / MOTORS / ENGINE							
	i_n	n_2 [min ⁻¹]	Rd	P_{t0}	GHA CLASSIC				MHA PREMIUM			
					T_2 [Nm]	P_1 [kW]	IEC B14	FS'	T_2 [Nm]	P_1 [kW]	IEC B14	FS'
Kg 11.0	7.5	187	0.87	2.5	80	1.8	90	2.7	67	1.5	90	2.7
	10	140	0.86	2.3	106	1.8		1.8	88	1.5		2.2
	15	93	0.83	1.9	153	1.8		1.3	128	1.5		1.6
	20	70	0.81	1.7	199	1.8		1.1	166	1.5		1.3
	25	56	0.78	1.5	200	1.5		1.0	200	1.5		1.0
	30	47	0.74	1.2	167	1.1		1.3	165	1.1		1.4
	40	35	0.71	1.1	213	1.1		1.1	213	1.1		1.1
	50	28	0.67	1.0	251	1.1		0.8	171	0.75		1.2
	65	22	0.63	0.90	300	1.1		0.6	137	0.5		1.4
	80	18	0.60	0.80	350	1.1		0.5	159	0.5		1.1
100	14	0.56	0.70	420	1.1	0.4	191	0.5	0.9			

* **ATTENZIONE:** la coppia massima utilizzabile [T_{2M}] deve essere calcolata utilizzando il fattore di servizio: $T_{2M} = T_2 \times FS'$

* **WARNING:** Maximum allowable torque [T_{2M}] must be calculated using the following service factor: $T_{2M} = T_2 \times FS'$

* **ACHTUNG:** das max. anwendbare Drehmoment [T_{2M}] muss mit folgendem Betriebsfaktor berechnet werden: $T_{2M} = T_2 \times FS'$

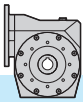

2.11 **Momenti d'inerzia** [Kg·cm²]
(riferiti all'albero veloce in entrata)

2.11 **Moments of inertia** [Kg·cm²]
(referred to input shaft)

2.11 **Trägheitsmoment** [Kg·cm²]
(bez. Antriebswelle)

GHA 30	i _n		
		B14	
		IEC 56	IEC 63
5	0.130	0.127	
7.5	0.112	0.109	
10	0.103	0.100	
15	0.097	0.094	
20	0.095	0.092	
25	0.094	0.091	
30	0.093	0.090	
40	0.093	0.090	
50	0.092	0.089	
65	0.079	-	
80	0.079	-	
100	0.078	-	

GHA 40	i _n		
		B14	
		IEC 63	IEC 71
5	0.391	0.463	
7.5	0.321	0.356	
10	0.272	0.347	
15	0.266	0.340	
20	0.263	0.338	
25	0.262	0.337	
30	0.262	0.337	
40	0.261	0.336	
50	0.261	-	
65	0.261	-	
80	0.261	-	
100	0.261	-	

GHA 50	i _n		
		B14	
		IEC 71	IEC 80
5	0.922	1.046	
7.5	0.684	0.935	
10	0.602	0.853	
15	0.543	0.794	
20	0.523	0.774	
25	0.513	0.764	
30	0.508	0.759	
40	0.503	0.755	
50	0.501	-	
65	0.499	-	
80	0.498	-	
100	0.498	-	

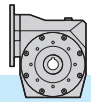

2.11 **Momenti d'inerzia** [Kg·cm²]
(riferiti all'albero veloce in entrata)

2.11 **Moments of inertia** [Kg·cm²]
(referred to input shaft)

2.11 **Trägheitsmoment** [Kg·cm²]
(bez. Antriebswelle)

GHA 63	i _n		
		B14	
		IEC 80	IEC 90
5	2.431	2.671	
7.5	1.949	2.269	
10	1.744	2.063	
15	1.597	1.916	
20	1.545	1.864	
25	1.514	1.833	
30	1.508	1.828	
40	1.495	-	
50	1.488	-	
65	1.484	-	
80	1.482	-	
100	1.481	-	

GHA 75	i _n	
		B14
		IEC 90
7.5	3.712	
10	3.234	
15	2.893	
20	2.774	
25	2.709	
30	2.689	
40	2.659	
50	2.642	
65	2.633	
80	2.629	
100	2.626	

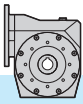

GHA.. PP

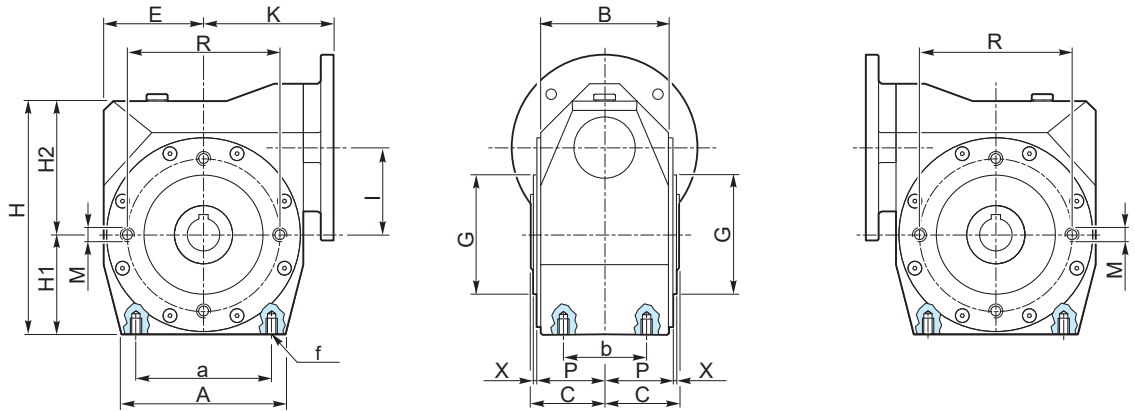

GHA.. CC

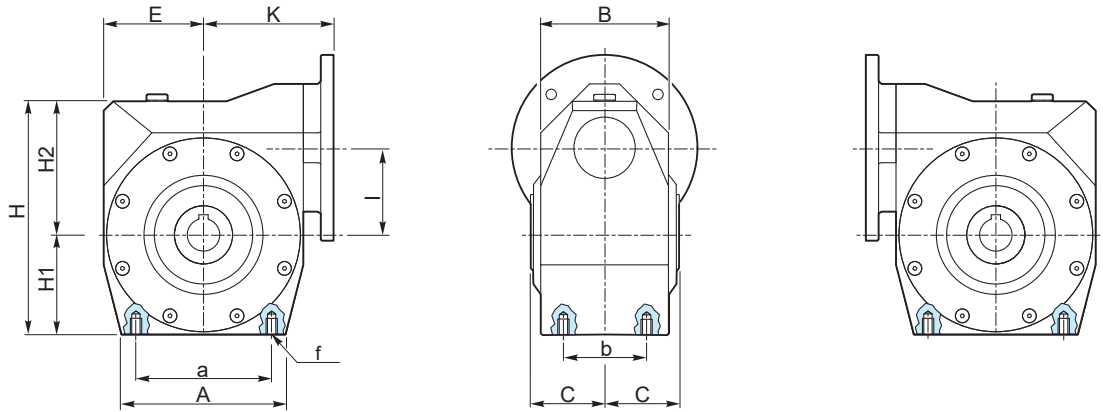

GHA.. PD

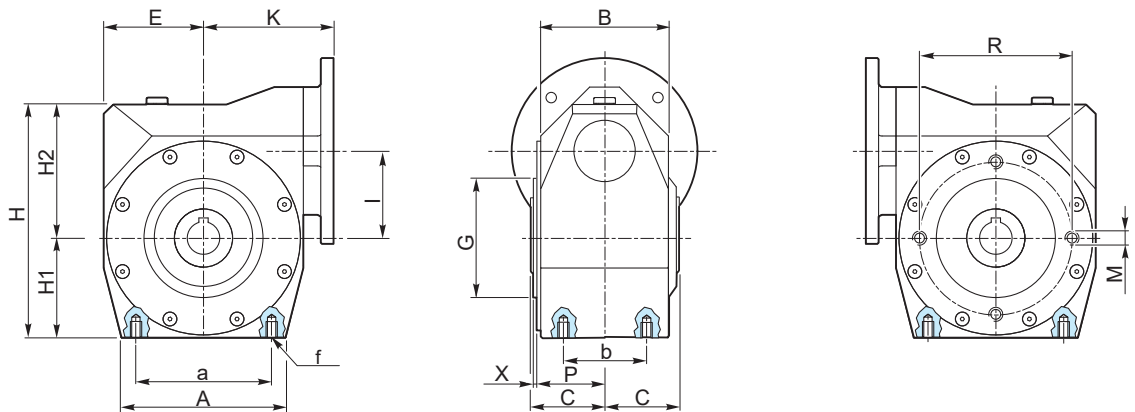

GHA.. PS

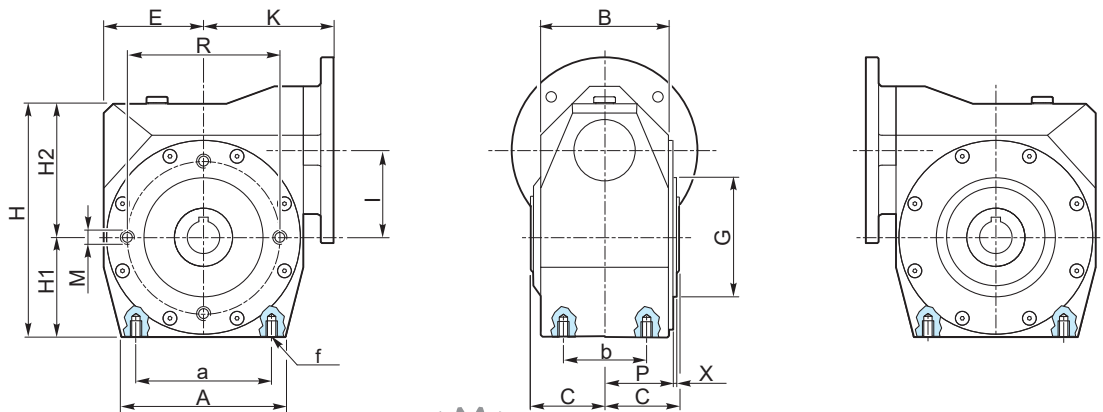

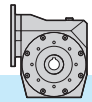

2.12 Dimensioni

2.12 Dimensions

2.12 Abmessungen

Flangia pendolare / Shaft-mounted flange / Aufsteckflansch

30

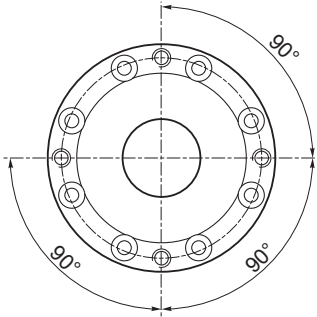

4 Fori / Holes / Bohrungen

40 - 50

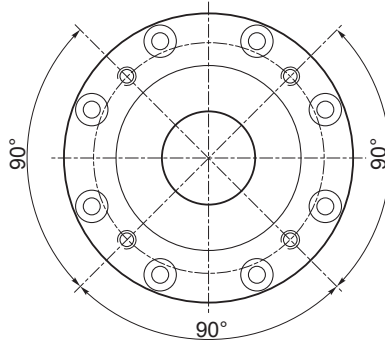

4 Fori / Holes / Bohrungen

63 - 75

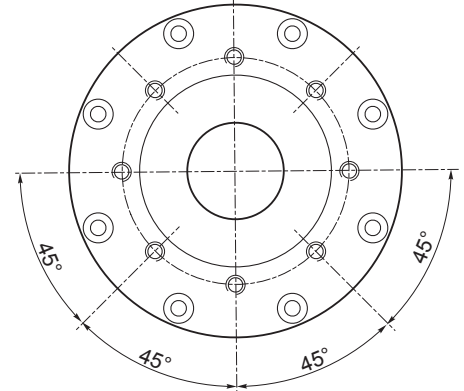

8 Fori / Holes / Bohrungen

Albero uscita cavo
Output hollow shaft
Abtriebshohlwelle

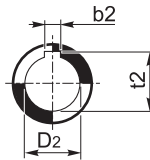

GHA	A	a	B	b	b ₂	C	D ₂ H8	E	f	G h8	H	H ₁	H ₂
30	66	54	56	44	5	31.5	14	40	M6 x 9	55	93	40	53
40	85	70	71	60	6	39	18	50	M6 x 11	60	116	50	66
50	95	80	84	70	8	46	25	60	M8 x 12	70	142	60	82
63	118	100	101	85	8	56	25	72	M8 x 16	80	173	72	101
75	142	120	110	90	8	60	28	86	M10 x 16	95	201	86	115

GHA	I	K	M	P	R	t ₂	X	
30	31.5	57	M6x8	29	65	16.3	1.5	1.5
40	40	75	M6X10	36.5	75	20.8	1.5	2.8
50	50	82	M8x10	43.5	85	28.3	1.5	4.5
63	63	96.8	M8x14	53	95	28.3	2	7.8
75	75	112	M8x14	57	115	31.3	2	12.8

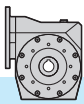

GHA.. + MHA PREMIUM

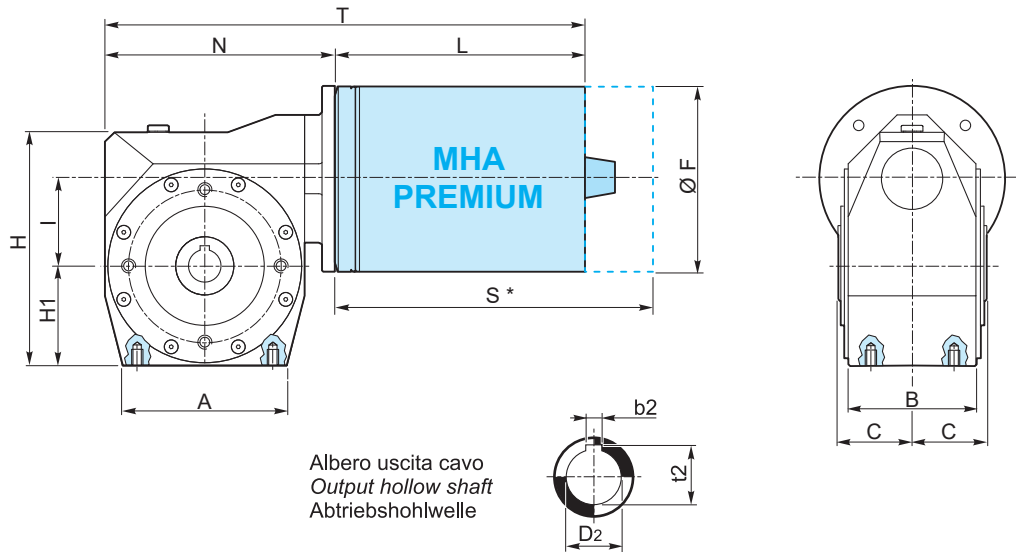

GHA	A	B	b ₂	C	D ₂ H8	H	H ₁	I	t ₂	N
30	66	56	5	31.5	14	93	40	31.5	16.3	97
40	85	71	6	39	18	116	50	40	20.8	125
50	95	85	8	46	25	142	60	50	28.3	148
63	118	103	8	56	25	173	72	63	28.3	168.8
75	142	112	8	60	28	201	86	75	31.3	198

B14

GHA... + MHA PREMIUM

	30		40		50		63		75	
MHA	71	71	80	71	80	90	80	90	90	112
F	118	118	134	118	134	150	134	150	150	190
L	223	223	234	223	234	239	234	239	239	307
T	320	348	359	371	382	387	402.8	407.8	437	505
kg	10.3 (0.13kW) 11 (0.18kW)	11.6 (0.13kW) 12.3 (0.18kW)	15.8 (0.25kW) 17.3 (0.37kW)	13.3 (0.13kW) 14 (0.18kW)	17.5 (0.25kW) 19 (0.37kW)	22.5 (0.5kW) 23.5 (0.75kW)	20.8 (0.25kW) 22.3 (0.37kW)	25.8 (0.5kW) 26.8 (0.75kW)	30.8 (0.5kW) 31.8 (0.75kW)	37.8 (1.1kW) 44.8 (1.5kW)

*S: quota valida solo per le versioni a richiesta (freno, encodeer, ecc.).

*S: value valid only for the versions on request (brake, encoder, ecc.).

*S: Wert gilt nur für die Versionen auf Anfrage (Bremse, Encoder, ecc.).

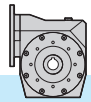



2.12 Dimensioni

2.12 Dimensions

2.12 Abmessungen

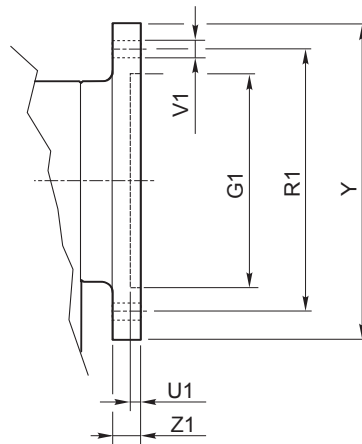
Flangia entrata / Input flange / Antriebsflansch



GHA	IEC	G ₁	R ₁	U ₁	V ₁		Y	Z ₁	Diametro fori PAM / Holes diameter IEC / IEC Durchmesser												
					∅				5	7.5	10	15	20	25	30	40	50	65	80	100	
30	56 B14	50	65	3.5	6	4	80	8	9	9	9	9	9	9	9	9	9	9	9	9	9
	63 B14	60	75	4	6	4	90	8	11	11	11	11	11	11	11	11	11	11	/	/	/
40	63 B14	60	75	3.5	6	4	90	8	11	11	11	11	11	11	11	11	11	11	11	11	11
	71 B14	70	85	3.5	7	4	105	8	14	14	14	14	14	14	14	14	14	/	/	/	/
50	71 B14	70	85	3.5	7	4	105	8	14	14	14	14	14	14	14	14	14	14	14	14	14
	80 B14	80	100	4	7	4	120	10	19	19	19	19	19	19	19	19	19	/	/	/	/
63	80 B14	80	100	4	7	4	120	10	19	19	19	19	19	19	19	19	19	19	19	19	19
	90 B14	95	115	4	8.5	4	140	10	24	24	24	24	24	24	24	24	/	/	/	/	/
75	90 B14	95	115	4	9	4	140	11	/	24	24	24	24	24	24	24	24	24	24	24	24

2.13 Lista parti di ricambio

2.13 Spare parts list

2.13 Ersatzteilliste

In fase di ordine delle parti di ricambio, specificare sempre n° particolare (vedi disegno esploso), data (1), n° codice (2) e n° variante (3). (Vedi targhetta).

When ordering please specify the spare part number (see exploded view) as well as the date (1), the article number (2) and the variant number (3) (see plate)

Bei der Bestellung von Ersatzteilen sind Ersatzteilnummer (s. Explosionszeichnung), Datum (1), Artikelnummer (2) und Variantennummer (3) anzugeben. (s. Schild)

CODICE: distinta base
CODE: base list
ART.-Nr.: Basisstückliste

TIPO: descrizione
TYPE: description
TYP: Bezeichnung

RAP: rapporto di riduzione
RATIO: reduction ratio
ÜBERS: Untersetzungsverhältnis

VARIANTE: codice alfanumerico
MODEL: alphanumeric code
VARIANTE: alphanumerische Nummer

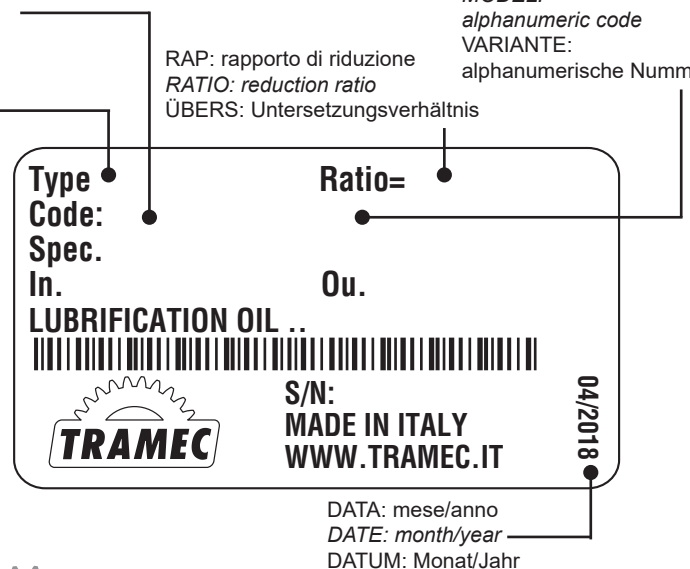

DATA: mese/anno
DATE: month/year
DATUM: Monat/Jahr

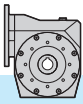

2.13 Lista parti di ricambio

2.13 Spare parts list

2.13 Ersatzteilliste

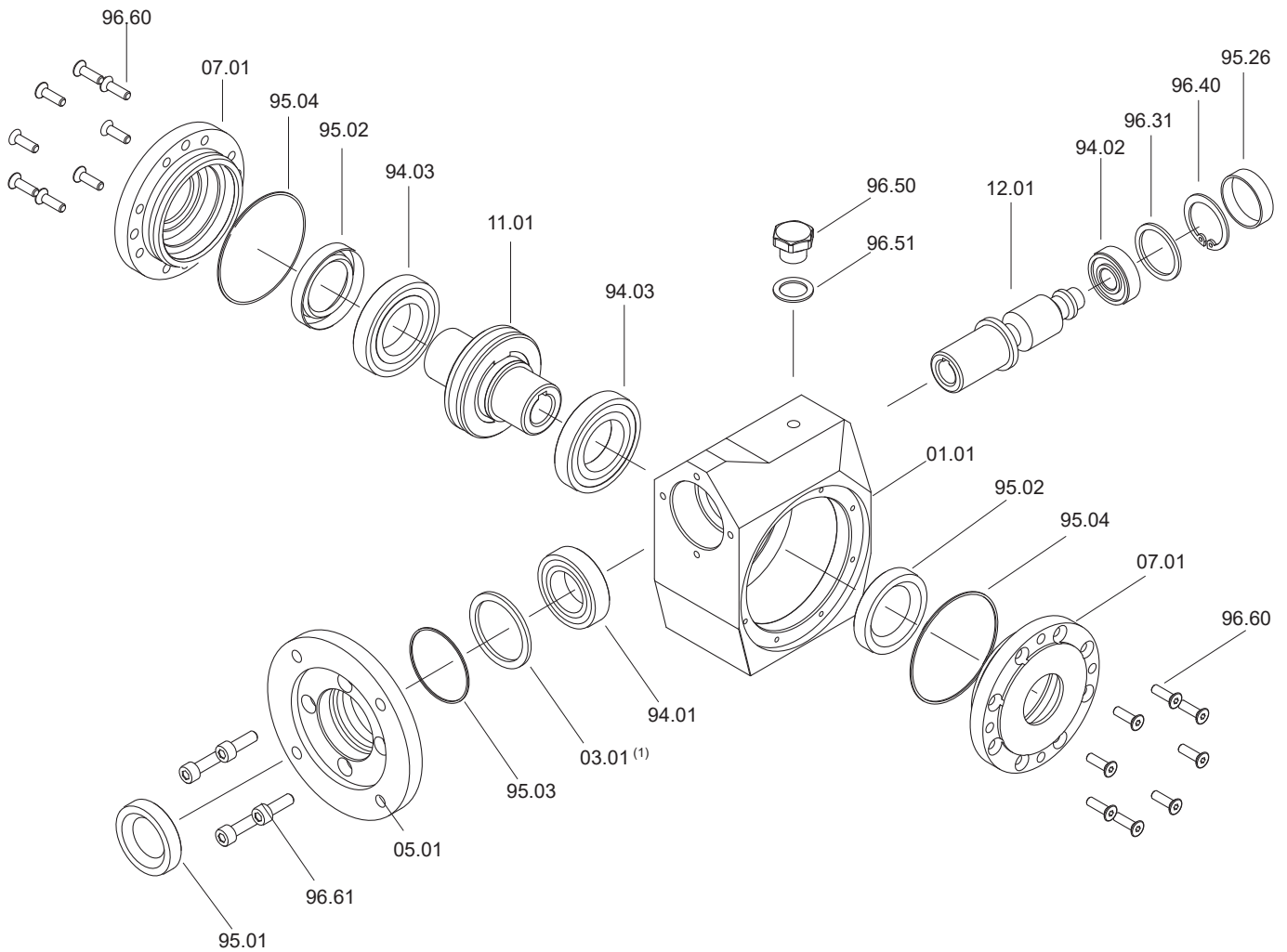

GHA	IEC	Cuscinetti / Bearings / Lager			Anelli di tenuta / Oilseals / Öldichtungen		OR		Cappellotto / Closed oil seal / Geschlossene Öldichtung
		94.01	94.02	94.03	95.01	95.02	95.03	95.04	95.26
30	56	61904 (20x37x9)	6000 (10x26x8)	16005 (25x47x8)	20/35/7	25/40/7	33x1.2	50x1.5	ø 26x7
	63				20/47/7	30/47/7			
40	63	6204 (20x47x14)	6201 (12x32x10)	16006 (30x55x9)	20/47/7	30/47/7	43x1.5	65x2	ø 32x7
	71	6005 (25x47x12)			25/47/7				
50	71	6005 (25x47x12)	6203 (17x40x12)	16008 (40x68x9)	25/47/7	40/62/8	50x1.5	82x2	ø 40x7
	80	6006 (30x55x13)			30/47/7				
63	80	6206 (30x62x16)	6204 C3 (20x47x14)	16008 (40x68x9)	30/62/7	40/62/8	56x1.5	102x2.5	ø 47x7
	90	6007 (35x62x14)			35/62/7				
75	90	6007 (35x62x14)	6205 C3 (25x52x15)	16010 (50x80x10)	35/62/7	50/72/8	60x3	123x3	ø 52x7

(1) Solo per GHA 63 PAM90 e 75 PAM 90 e 100 / Only for GHA 63 PAM 90 and 75 PAM 90 and 100 / Nur für GHA 63 PAM 90, 75 PAM 90 und 100

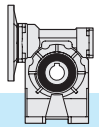

3.0

RIDUTTORE A VITE SENZA FINE SERIE GK

GK WORM GEARBOXES

SCHNECKENGETRIEBE GK

3.1	Caratteristiche	<i>Characteristics</i>	Merkmale	34
3.2	Designazione	<i>Designation</i>	Bezeichnung	35
3.3	Rendimento	<i>Efficiency</i>	Wirkungsgrad	36
3.4	Irreversibilità	<i>Irreversibility</i>	Selbsthemmung	36
3.5	Gioco angolare	<i>Backlash</i>	Winkelspiel	37
3.6	Carichi radiali	<i>Radial load</i>	Radialbelastungen	38
3.7	Senso di rotazione	<i>Direction of rotation</i>	Drehrichtung	38
3.8	Lubrificazione e posizioni di montaggio	<i>Lubrication and mounting position</i>	Schmierung und Einbaulage	39
3.9	Posizione morsettiera	<i>Terminal board position</i>	Lage des Klemmenbrett	39
3.10	Dati tecnici	<i>Technical data</i>	Technische Daten	40
3.11	Momenti d'inerzia	<i>Moments of inertia</i>	Trägheitsmoment	46
3.12	Dimensioni	<i>Dimensions</i>	Abmessungen	45
3.13	Entrata supplementare	<i>Additional input</i>	Zusatzantrieb	49
3.14	Lista parti di ricambio	<i>Spare parts list</i>	Ersatzteilliste	50

GHA - CLASSIC

La serie CLASSIC costituisce la serie standard all'interno della gamma di riduttori GHA.

Le speciali caratteristiche NANOTECHNOLOGICHE del rivestimento della carcassa e il suo design esterno, certificato HACCP, rendono i riduttori di questa serie particolarmente adatti per le applicazioni in ambienti ALIMENTARE e FARMACEUTICO.

Il riduttore non è adatto al contatto con gli alimenti.

GHA - CLASSIC

The CLASSIC series is the standard series within the range of GHA reducers.

The special NANOTECHNOLOGICAL properties of the case coating and its external construction, certified by HACCP, make the gearboxes of this series particularly suitable for applications in FOOD and PHARMACEUTICAL environments.

The reducer is not suitable for contact with food.

GHA - CLASSIC

Die Serie CLASSIC ist die Standardbaureihe innerhalb der Produktpalette der GHA-behandelten Getriebe.

Durch die spezielle NANOTECHNOLOGISCHEN Eigenschaften der Gehäusebeschichtung und das Design des Gehäuses (zertifiziert durch HACCP), sind die Getriebe dieser Serie besonders geeignet für den Einsatz in LEBENSMITTEL- und PHARMAZEUTISCHER Umgebung.

Das Getriebe ist nicht für den Kontakt mit Lebensmitteln geeignet.

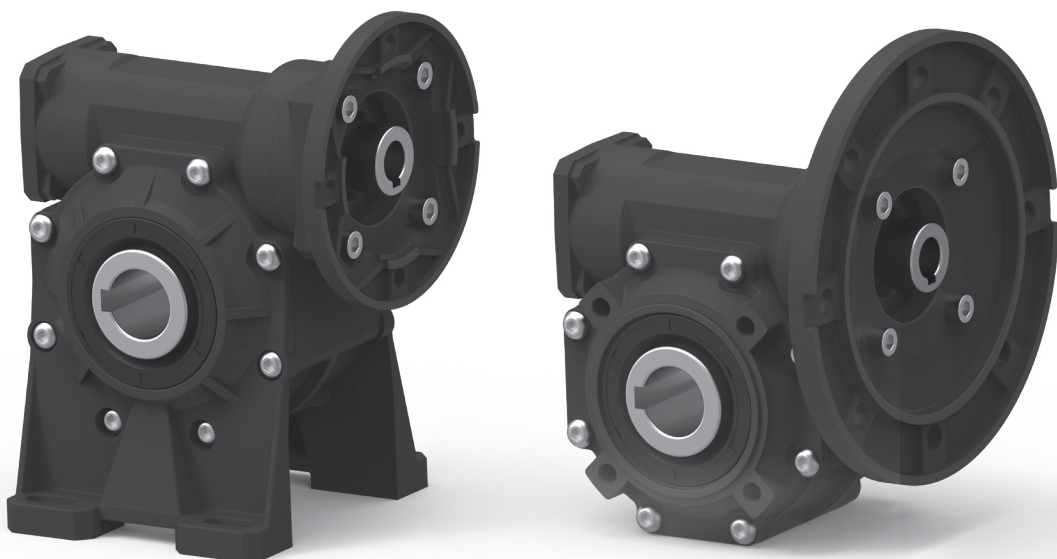

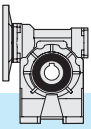

3.1 Caratteristiche

- I riduttori della serie a vite senza fine GK si presentano estremamente leggeri grazie alla forma compatta della carcassa in alluminio pressofuso per tutte le grandezze.
- La serie presenta una svariata possibilità di versioni, con e senza piedi, che la rendono più versatile nell'impiego in ogni tipologia di applicazione.
- La serie GK è disponibile esclusivamente nella versione predisposta per attacco motore (PAM) e non con albero entrata maschio.
- La vite senza fine è in acciaio legato cementato-temprato ed è rettificata.
- La corona ha il mozzo in acciaio INOX AISI 316 e l'anello dentato in bronzo GCuSn12.
- Le carcasse e flange in alluminio sono sabbiate e trattate con tecnologia G.H.A.®
- Viene fornito l'albero uscita cavo di serie ed esiste un'ampia disponibilità di accessori: seconda entrata, kit protezione albero cavo.

3.1 Characteristics

- *The GK worm gearboxes are extremely light thanks to the compact shape of the housing which is in die-cast aluminum for all sizes.*
- *This series features a wide range of versions, with and without feet, which makes it extremely versatile for utilization in various applications.*
- *The GK series is available for motor mounting version (PAM) only and not with the male input shaft.*
- *The worm shaft is made of hardened-bonded steel and ground.*
- *The wheel has an AISI 316 stainless steel hub with a toothed ring made in bronze GcuSn12.*
- *Aluminum housings and flanges are sandblasted and treated in accordance with G.H.A.® technology.*
- *The hollow output shaft is supplied as standard. A broad range of accessories is available: second input, hollow shaft protection kit.*

3.1 Merkmale

- Die Schneckengetriebe der Serie GK sind, dank der kompakten Form des Gehäuses, sehr leicht. Das Gehäuse aller Baugrößen ist aus Druckgussaluminium gefertigt.
- Diese Serie ist in vielen Ausführungen, mit und ohne Füße erhältlich, was eine vielseitige Anwendbarkeit in unterschiedlichsten Applikationen ermöglicht.
- Die Serie GK ist nur mit Motoranbau (IEC) Version und nicht mit einer freien Antriebswelle verfügbar.
- Die Schneckenwelle ist aus einsatzgehärtetem, abgeschrecktem und daraufhin geschliffenem Legierungsstahl
- Das Schneckenrad besteht aus einer Nabe aus Edelstahl AISI 316 und einer Bronze- Verzahnung GCuSn12.
- Die Aluminiumgehäuse und Flansche sind sandgestrahlt und mit G.H.A.® - Technik behandelt.
- Die Hohlwelle gehört zur serienmäßigen Ausstattung. Eine breite Auswahl an Zubehör ist erhältlich: Zweiteingang, Schutzvorrichtung für Hohlwelle.

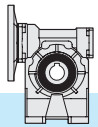

3.2 Designazione

3.2 Designation

3.2 Bezeichnung

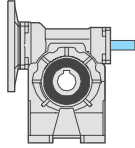
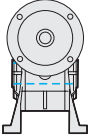
Riduttore Gearbox Getriebe	Tipo entrata Input type Antriebsart	Grandezza Size Größe	Versione Version Ausführung	Rapporto rid. Ratio Untersetzung	Predispos. att. mot. Motor coupling Motoranschluss	Posizione di mont. Mounting position Einbaulage	Seconda entrata Additional input Zusatzantrieb	Albero uscita cavo Hollow output shaft Abtriebshohlwelle
GK	C	50	F1S	10	P.A.M	B3	SeA	H25
Riduttore a vite senza fine Wormgearbox Schneckengetriebe		30 40 50 63 75 89	A1-A2 B1-B2 V1-V2 P F1S-F2S F3S F1D-F2D F3D	5 7.5 10 15 20 25 30 40 50 65 80 100	56 63 71 80 90 100 112	B3 B6 B7 B8 V5 V6	 SeA	 H..

Versioni

Versions

Ausführungen

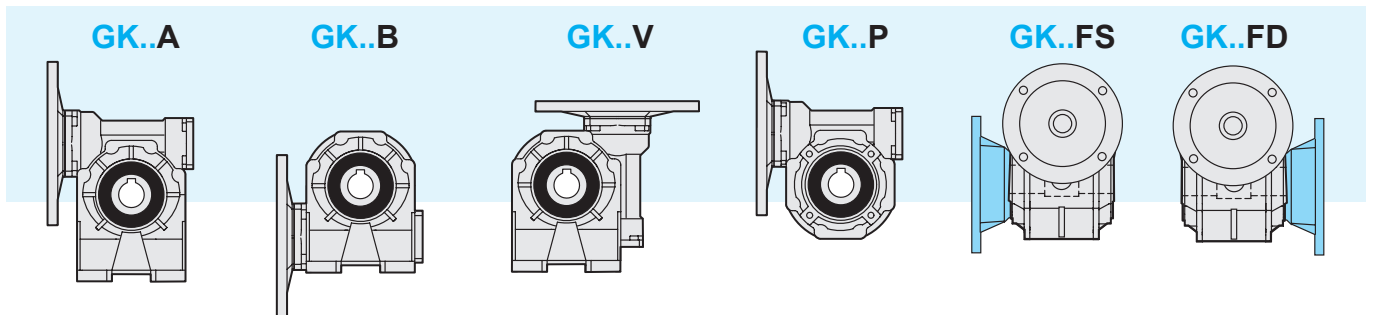

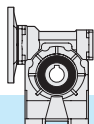

3.3 Rendimento

Rd - È il rendimento dinamico, definito come rapporto tra la potenza in uscita P_2 e quella in entrata P_1 . Dipende principalmente dalla velocità di strisciamento, dal tipo di lubrificante e dall'angolo d'elica. I valori indicati nelle tabelle sono validi se si applica la corrispondente coppia in uscita. In fase di rodaggio, circa le prime 300 ore di funzionamento sotto carico, il valore deve essere considerato inferiore del 30% rispetto a quello indicato in tabella.

Rs - È il rendimento statico che si ha al momento dell'avviamento del riduttore e varia in base al rapporto di riduzione. Risulta importante, per una corretta valutazione del riduttore da impiegare, nelle applicazioni in cui non si raggiungono mai le condizioni di regime come nei funzionamenti intermittenti. Analogamente al caso dinamico, anche il rendimento statico durante il rodaggio risulta inferiore del 30% rispetto al valore indicato in tabella.

3.3 Efficiency

Rd - dynamic efficiency, defined as the ratio between P_2 output power and P_1 input power. It mainly depends on the slipping speed, the type of lubricant and the lead angle. The values reported in the table are valid when the corresponding output torque is applied. During the first 300 operating hours under load, the value to be considered is 30% lower than that reported in the table.

Rs - static efficiency at gearbox start-up; it changes depending on the reduction ratio. Rs value is important for selecting the right gearbox for applications where a steady state is never achieved, as for intermittent duty applications. Same as dynamic efficiency, static efficiency too during the running-in period will be 30% lower than the value reported in the table.

3.3 Wirkungsgrad

Rd - dynamischer Wirkungsgrad, ist das Verhältnis zwischen P_2 Abtriebsleistung und P_1 Antriebsleistung. Rd Wert wird durch Gleitgeschwindigkeit, Art des Schmiermittels und Steigungswinkel beeinflusst. Die Tabellen zeigen die Werte die gültig sind wenn das entsprechende Abtriebsdrehmoment gegeben ist. Während der Einlaufzeit in den ersten 300 Betriebsstunden unter Belastung, ist dieser Wert 30% niedriger als der in der Leistungstabelle angegebenen Wert.

Rs - statischer Wirkungsgrad beim Getriebebestart und in Abhängigkeit zur Untersetzung. Der Wert Rs ist wichtig für die Auswahl des richtigen Getriebes für Anwendungen wo ein stetiger Betrieb nicht auftritt, wie bei Anwendungen mit Aussetzbetrieb. Der statischer Wirkungsgrad auch während der Einlaufzeit wird 30% niedriger als der in der Tabelle angegebenen Wert.

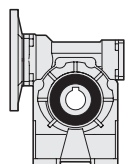

GK	Rs											
	5	7.5	10	15	20	25	30	40	50	65	80	100
30	0.70	0.67	0.62	0.55	0.47	0.43	0.39	0.30	0.27	0.25	0.22	0.21
40	0.69	0.67	0.63	0.55	0.52	0.45	0.40	0.35	0.29	0.26	0.25	0.23
50	0.69	0.68	0.65	0.58	0.53	0.47	0.41	0.37	0.32	0.28	0.25	0.23
63	0.70	0.68	0.65	0.57	0.55	0.50	0.47	0.38	0.33	0.29	0.28	0.23
75	/	0.68	0.65	0.58	0.55	0.51	0.43	0.39	0.35	0.31	0.28	0.24
89	/	0.68	0.65	0.58	0.55	0.52	0.45	0.39	0.36	0.32	0.29	0.25

3.4 Irreversibilità

Nelle applicazioni dove è necessario evitare la trasmissione del moto retrogrado o sostenere il carico, in assenza di alimentazione elettrica, è consigliabile adottare freni esterni.

Nei riduttori a vite senza fine emerge questa caratteristica naturale, denominata grado di irreversibilità, che cresce con l'aumentare del rapporto di riduzione in quanto strettamente legata al relativo rendimento.

Per ottenere alti gradi di irreversibilità occorre quindi adottare i rapporti di riduzione più elevati, senza dimenticare che, il rendimento, tende a crescere durante le prime 500 ore di funzionamento per poi stabilizzarsi sui valori riportati a catalogo.

3.4 Irreversibility

The use of external brakes is advised in case of applications where backwards motion must be hindered and the load must be held should the feed be cut off.

Some worm gearboxes feature natural irreversibility. The higher the ratio, the higher is the irreversibility, since it is strictly dependent on the relative efficiency.

In order to achieve high irreversibility it is therefore necessary to select higher efficiency reduction ratios not to forget that the efficiency is growing during the first 500 hours life until it stabilizes to the values mentioned in the catalogue.

3.4 Selbsthemmung

Aussenbremsen sind bei Anwendungen zu benutzen, bei denen Rückbewegung vermeiden werden muss oder die Last auch im Falle von Fehlen an Speisung gehalten werden muss.

Einige Schneckengetriebe sind selbsthemmend. Je höher die Untersetzung ist, desto höher ist die Selbsthemmung, da diese stark vom jeweiligen Wirkungsgrad abhängig ist. Um eine höhere Selbsthemmung zu erreichen, wählen Sie bitte höhere Untersetzungsverhältnisse.

Bitte beachten Sie, dass der Wirkungsgrad der Getriebe in den ersten 500 Betriebsstunden ansteigt und sich erst anschließend auf die im Katalog angegebenen Werte stabilisiert.

Irreversibilità statica

Condizione di impedimento alla rotazione comandata dall'albero lento senza escludere possibili ritorni lenti nel caso in cui il carico sia sottoposto a vibrazioni.

Rs < 0.45 si ha irreversibilità
Rs = 0.45 ÷ 0.55 irreversibilità incerta
Rs > 0.55 si ha reversibilità

Static irreversibility

Static irreversibility occurs when the rotation controlled by the output shaft is hindered; possible slow returns cannot be excluded should the load be subject to vibrations.

Rs < 0.45 provides irreversibility
Rs = 0.45 ÷ 0.55 irreversibility is uncertain
Rs > 0.55 reversibility is possible

Statische Selbsthemmung

Statische Selbsthemmung liegt vor, wenn die von Abtriebswelle gesteuerten Drehung gehindert wird. Langsamer Rücklauf ist möglich, falls die Last Schwingungen ausgesetzt wird.

Rs < 0.45 es liegt Selbsthemmung vor
Rs = 0.45 ÷ 0.55 ungewisse Selbsthemmung
Rs > 0.55 es liegt Reversibilität vor

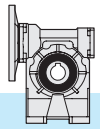

Irreversibilità dinamica

Condizione di arresto e quindi di sostegno del carico nel momento in cui cessa l'azione di comando. La condizione è più difficile da ottenere in quanto viene influenzata dal rendimento dinamico, dalla velocità di rotazione, da eventuali vibrazioni che il carico può generare e dalla direzione del movimento rispetto al carico.

Quest'ultima condizione è molto evidente nei sollevamenti: un carico in salita, cessando l'azione di comando, deve arrestarsi e quindi assumere velocità zero (rendimento statico) prima di invertire il moto e cadere per gravità.

Un carico in discesa tende invece a proseguire nel suo moto ostacolato, nella caduta, dal solo rendimento dinamico.

Rd < 0.45 si ha irreversibilità
Rd = 0.45 ÷ 0.55 irreversibilità incerta
Rd > 0.55 si ha reversibilità

Dynamic irreversibility

Dynamic irreversibility is characterized by stillstand and hold of the load when the drive stops. It is more difficult to achieve this condition because it is influenced by dynamic efficiency, speed of rotation and possible vibrations generated by the motion direction with regard to the load.

This last condition is much more evident during the lifting : if the drive stops during the lifting of the load this has to come to a speed equals to zero (static irreversibility) before the reversal of motion rotation and its drop for gravity.

On the contrary the load during its descent gets its motion obstructed by its dynamic efficiency.

Rd < 0.45 provides irreversibility
Rd = 0.45 ÷ 0.55 irreversibility is uncertain
Rd > 0.55 reversibility is possible

Dinamische Selbsthemmung

Stillstand und Stütze der Last beim Aussetzen der Steuerung. Diese Bedingung ist schwieriger zu erreichen, da sie vom dynamischen Wirkungsgrad, der Drehzahl und von der Last verursachten möglichen Vibrationen abhängig ist

Dieser letzte Fall kommt bei Hubanwendungen stark zu tragen. Wenn der Antrieb während dem Hub stoppt, muss die Last eine Geschwindigkeit von annähernd null erreichen (statische Irreversibilität), bevor die Rotation sich umkehrt und die Last durch die Gravitation nach unten fährt.

Dem entgegengesetzt bekommt die Last durch die Abwärtsbewegung Ihre dynamische Effizienz.

Rd < 0.45 es liegt Selbsthemmung vor
Rd = 0.45 ÷ 0.55 ungewisse Selbsthemmung
Rd > 0.55 es liegt Reversibilität vor

3.5 Gioco angolare

Gioco angolare standard

Misurato bloccando l'albero entrata, e ruotando l'albero uscita nelle due direzioni applicando la coppia strettamente necessaria a creare il contatto tra i denti degli ingranaggi, al massimo pari al 2% della coppia nominale (T_{2M}).

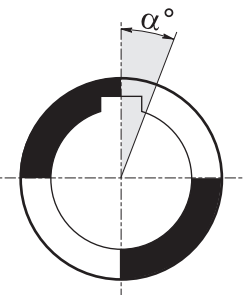

3.5 Backlash

Backlash

Angular backlash measured after having blocked the input shaft by rotating output shaft in both directions and applying the torque which is strictly necessary to create a contact between the teeth of the gears. The applied torque should be at most 2% of the max. torque (T_{2M}).

3.5 Winkelspiel

Winkelspiel

Nachdem die Antriebswelle blockiert worden ist, darf das Winkelspiel auf die Abtriebswelle bemessen werden. Dabei soll die Antriebswelle in beiden Richtungen gedreht werden und ein Drehmoment ausgeübt werden, das zur Entstehen eines Kontaktes zwischen den Zähnen genuegt. Das ausgeübte Drehmoment soll höchstens 2% des max. von Getrieben garantierten Drehmoment (T_{2M}) sein.

GK						
i_n	30	40	50	63	75	89
	max	max	max	max	max	max
5	16'	13.5'	10.5'	10'	/	/
7.5	16'	13.5'	10.5'	10'	10'	9.5'
10	16'	13.5'	10.5'	10'	10'	9'
15	16'	13.5'	10.5'	10'	10'	9'
20	14.5'	12'	9.5'	8.5'	8.5'	8.5'
25	14.5'	12'	9.5'	8.5'	8.5'	8.5'
30	14.5'	12'	8.5'	8.5'	8.5'	8.5'
40	14.5'	12'	9.5'	8.5'	8.5'	8'
50	14'	12'	9.5'	8.5'	8.5'	8'
65	14'	12'	9'	8'	8'	8'
80	13.5'	11.5'	9'	7.5'	7.5'	7.5'
100	13'	11'	9'	7.5'	7.5'	7.5'

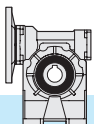

3.6 Carichi radiali

Carichi radiali Fr_2 e assiali Fa_2 sull'albero uscita [N]

Se il carico radiale sull'albero non è applicato a metà della sporgenza dell'albero, il valore del carico ammissibile deve essere valutato utilizzando la formula che si riferisce ad Fry_2 , in cui i valori di a, b e Fr_2 sono riportati nelle tabelle relative ai carichi radiali.

Nel caso di alberi bisporgenti il valore del carico applicabile a ciascuna estremità è uguale ai 2/3 del valore di tabella, purché i carichi applicati siano uguali di intensità e direzione ed agiscano nello stesso senso. Diversamente contattare il servizio tecnico.

3.6 Radial load

Fr_2 radial loads and Fa_2 axial loads on the output shaft [N]

Should the radial load affect the shaft not at the half-way point of its projection but at a different point, the value of the admissible load has to be calculated using the Fry_2 formula: a, b and Fr_2 values are reported in the radial load tables.

With regard to double-projecting shafts, the load applicable at each end is 2/3 of the value given in the table, on condition that the applied loads feature same intensity and direction and that they act in the same direction.

Otherwise please contact the technical department.

3.6 Radialbelastungen

Fr_2 Radialbelastungen und Fa_2 Axialbelastungen auf die Abtriebswelle [N]

Falls die Radialbelastungen nicht in dem Mittelpunkt der herausragenden Welle sondern in einem anderen Punkt wirken, soll die zulässige Belastung mit der Formel bezüglich Fry_2 kalkuliert werden: a, b und Fr_2 Werte sind aus der Tabelle der Radialbelastungen zu entnehmen.

Bei doppelseitigen Abtriebswellen ist die Belastung, die an jedem Ende anwendbar ist, 2/3 des in der Tabelle angegebenen Wertes unter der Bedingung, dass die Belastungen die selbe Stärke und Richtung aufweisen und dass sie in der selben Richtung wirken. Andernfalls muß mit dem technischen Büro Rücksprache gehalten werden.

I carichi radiali indicati nelle tabelle si intendono applicati a metà della sporgenza dell'albero e sono riferiti ai riduttori operanti con fattore di servizio 1.

The radial loads indicated in the chart are considered to be applied at the half-way point of the shaft projection, and refer to gear units operating with service factor 1.

Die Radialbelastungen, die in den Tabellen angegeben werden, gelten für Ansatzpunkte in der Mitte des herausragenden Wellenteils und für Getriebe mit Betriebsfaktor 1.

		GK											
$n_1=1400$ rpm		30		40		50		63		75		89	
i_n	n_2 [rpm]	a = 66.5 b = 49		a = 83.5 b = 60.5		a = 102 b = 73.5		a = 122.5 b = 93.5		a = 134 b = 100		a = 163 b = 118	
		Fr_2	Fa_2	Fr_2	Fa_2	Fr_2	Fa_2	Fr_2	Fa_2	Fr_2	Fa_2	Fr_2	Fa_2
5	280	700	140	1400	280	1400	300	1800	360	/	/	/	/
7.5	187	750	150	1500	300	1650	330	2100	420	2500	500	2600	520
10	140	800	160	1600	320	1800	360	2300	460	2800	560	3000	600
15	93	850	170	1700	340	1950	390	2600	520	3000	600	3400	680
20	70	900	180	1800	360	2200	440	2800	560	3300	660	3800	760
25	56	950	190	1900	380	2400	480	3100	620	3700	740	4100	820
30	47	1000	200	2000	400	2600	520	3400	680	4000	800	4500	900
40	35	1050	210	2100	420	2850	570	3700	740	4400	880	4900	980
50	28	1100	220	2200	440	3100	620	4000	800	4850	970	5300	1060
60	23	1150	230	2400	480	3200	640	4200	840	5000	1000	5600	1120
63	22	1250	250	2500	500	3400	680	4450	890	5300	1060	5900	1180
80	17.5	1350	270	2700	540	3800	760	4900	980	5800	1160	6500	1300
100	14	1500	300	3000	600	4000	800	5400	1080	6500	1300	7000	1400

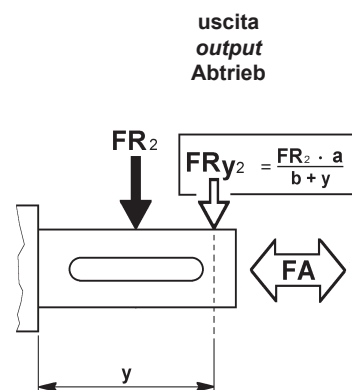

3.7 Senso di rotazione

3.7 Direction of rotation

3.7 Drehrichtung

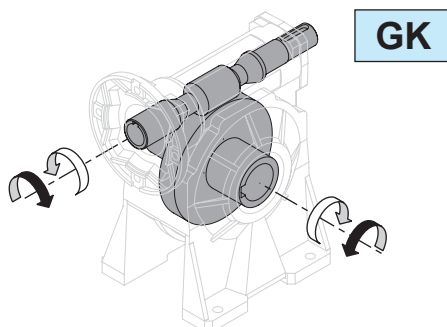

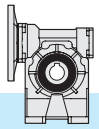

3.8 Lubrificazione

I riduttori a vite senza fine serie GK sono forniti completi di lubrificante sintetico per uso alimentare: OLIO FUCHS CASSIDA FLUID 320.

Si raccomanda di precisare sempre, in fase di ordine, la posizione di montaggio desiderata.

3.8 Lubrication

The GK series worm gearboxes are supplied complete with synthetic lubricant for food use: FUCHS CASSIDA FLUID 320 OIL.

Mounting position always to be specified when ordering.

3.8 Schmierung

Die Schneckengetriebe der Serie GK werden mit synthetischem Lebensmittelöl FUCHS CASSIDA FLUID 320 geliefert.

Bei der Bestellung bitte immer die gewünschte Einbaulage angeben.

Posizioni di montaggio

Mounting positions

Einbaulagen

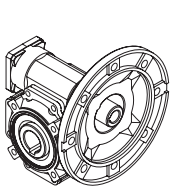

B3

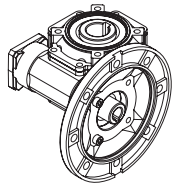

B6

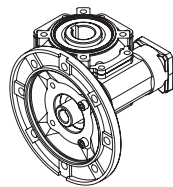

B7

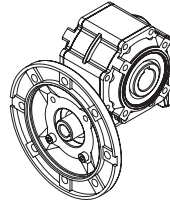

B8

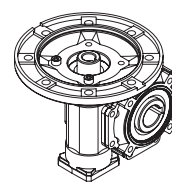

V5

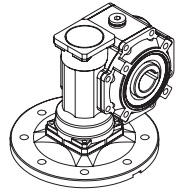

V6

E' presente un solo tappo di riempimento olio.

Aluminium housings have one filling plug only.

Gehäuse aus Aluminium verfügen über nur eine Einfüllschraube.

		Q.tà olio / Oil quantity / Schmiermittelmenge [lt]			
		Posizione di montaggio / Mounting position / Einbaulage			
		B3	B6 - B7	B8	V5 - V6
GK	30	0.015	0.030		0.015
	40	0.040	0.060		0.040
	50	0.080	0.120		0.080
	63	0.160	0.220		0.160
	75	0.260	0.340		0.260
	89	1	0.8	0.8	1.3

3.9 Posizione morsettiera

3.9 Terminal board position

3.9 Lage der Klemmenkaste

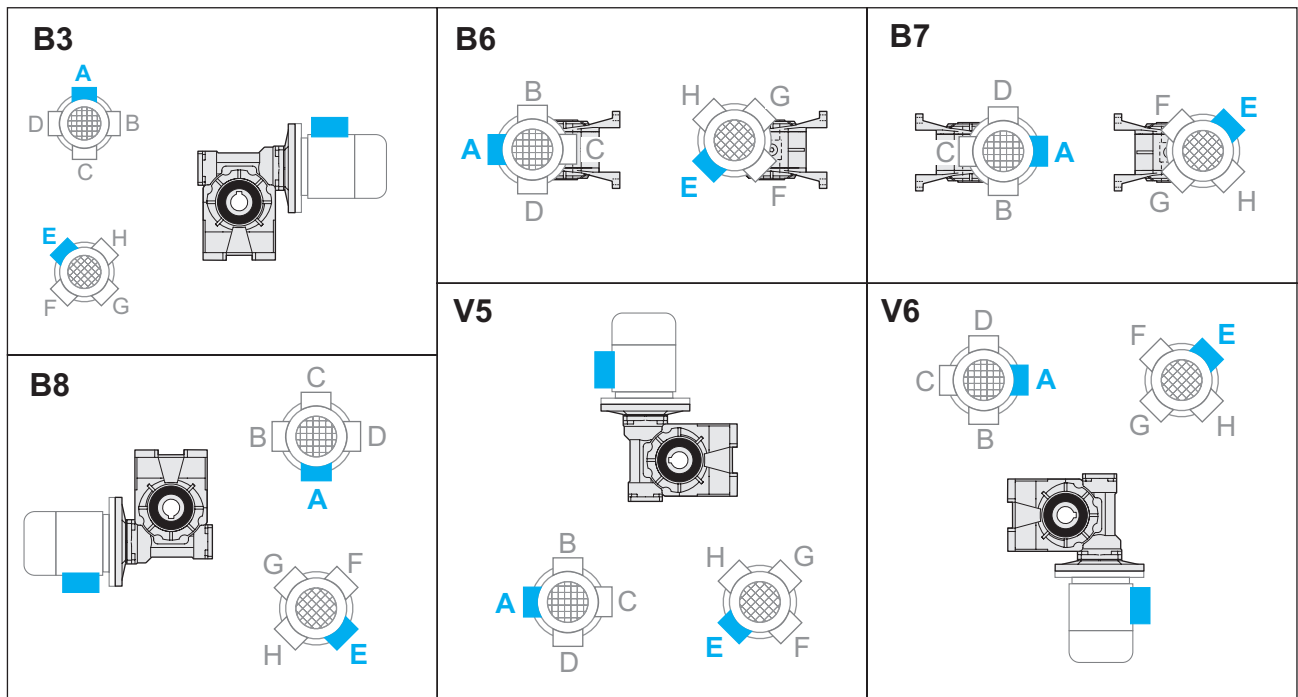

Specificare sempre in fase di ordinazione la posizione di montaggio e la forma costruttiva.

Posizione morsettiera v. pag. 51 (PM=1; PM=2)

Mounting position always to be specified when ordering.

Terminal board position see page 51 (PM=1; PM=2)

Bei der Bestellung immer die gewünschte Montageposition und Bauform angeben.

Lage der Klemmenkaste Seite 51 (PM=1; PM=2)

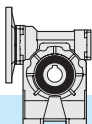

3.10 Dati tecnici

3.10 Technical data

3.10 Technische Daten

GKC 30	$n_1 = 2800$				MOTORI / MOTORS / ENGINE GHA CLASSIC				Input - IEC	
	i_n	n_2 [min ⁻¹]	Rd	P_{10}	T_2 [Nm]	P_1 [kW]	FS'	B5/B14		
								63	56	
 1.2	5	560	0.89	—	5.6	0.37	2.5	63	56	
	7.5	373	0.86		8	0.37	2.0			
	10	280	0.84		11	0.37	1.5			
	15	187	0.81		15	0.37	1.1			
	20	140	0.76		13	0.25	1.2			
	25	112	0.74		16	0.25	1.0			
	30	93	0.71		13	0.18	1.0			
	40	70	0.65		16	0.18	1.0			
	50	56	0.62		14	0.13	1.1			
	65	43	0.57		17	0.13	1.0			
	80	35	0.54		13	0.09	1.0			
	100	28	0.52		16	0.09	0.8			

GKC 30	$n_1 = 1400$				MOTORI / MOTORS / ENGINE GHA CLASSIC				Input - IEC	
	i_n	n_2 [min ⁻¹]	Rd	P_{10}	T_2 [Nm]	P_1 [kW]	FS'	B5/B14		
								63	56	
 1.2	5	280	0.87	0.40	6.5	0.22	2.9	63	56	
	7.5	187	0.84	0.40	9	0.22	2.2			
	10	140	0.82	0.40	12	0.22	1.8			
	15	93	0.77	0.30	17	0.22	1.3			
	20	70	0.72	0.20	18	0.18	1.1			
	25	56	0.69	0.20	21	0.18	1.0			
	30	47	0.66	0.20	18	0.13	1.1			
	40	35	0.59	0.20	21	0.13	1.0			
	50	28	0.55	0.20	17	0.09	1.1			
	65	22	0.51	0.10	20	0.09	1.0			
	80	18	0.48	0.10	16	0.06	1.0			
	100	14	0.45	0.10	18	0.06	0.8			

GKC 30	$n_1 = 900$				MOTORI / MOTORS / ENGINE GHA CLASSIC				Input - IEC	
	i_n	n_2 [min ⁻¹]	Rd	P_{10}	T_2 [Nm]	P_1 [kW]	FS'	B5/B14		
								63	56	
 1.2	5	180	0.85	—	5.9	0.13	3.9	63	56	
	7.5	120	0.82		9	0.13	2.9			
	10	90	0.80		11	0.13	2.3			
	15	60	0.75		15	0.13	1.6			
	20	45	0.69		19	0.13	1.2			
	25	36	0.66		23	0.13	1.1			
	30	30	0.63		18	0.09	1.2			
	40	23	0.55		21	0.09	1.1			
	50	18	0.52		16	0.06	1.3			
	65	14	0.48		20	0.06	1.1			
	80	11	0.44		11	0.03	1.7			
	100	9	0.42		13	0.03	1.1			

GKC 30	$n_1 = 500$				MOTORI / MOTORS / ENGINE GHA CLASSIC				Input - IEC	
	i_n	n_2 [min ⁻¹]	Rd	P_{10}	T_2 [Nm]	P_1 [kW]	FS'	B5/B14		
								63	56	
 1.2	5	100	0.83	—	—	—	—	63	56	
	7.5	67	0.80		—	—	—			
	10	50	0.77		—	—	—			
	15	33	0.72		—	—	—			
	20	25	0.66		—	—	—			
	25	20	0.62		—	—	—			
	30	17	0.59		—	—	—			
	40	13	0.51		—	—	—			
	50	10	0.48		—	—	—			
	65	8	0.43		—	—	—			
	80	6	0.40		—	—	—			
	100	5	0.38		—	—	—			

* **ATTENZIONE:** la coppia massima utilizzabile $[T_{2M}]$ deve essere calcolata utilizzando il fattore di servizio: $T_{2M} = T_2 \times FS'$

* **WARNING:** Maximum allowable torque $[T_{2M}]$ must be calculated using the following service factor: $T_{2M} = T_2 \times FS'$

* **ACHTUNG:** das max. anwendbare Drehmoment $[T_{2M}]$ muss mit folgendem Betriebsfaktor berechnet werden: $T_{2M} = T_2 \times FS'$

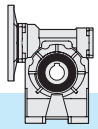



3.10 Dati tecnici

3.10 Technical data

3.10 Technische Daten

GKC 40	$n_1 = 2800$				MOTORI / MOTORS / ENGINE GHA CLASSIC					
	i_n	n_2 [min ⁻¹]	Rd	P_{t0}	T_2 [Nm]	P_1 [kW]	FS'	Input - IEC B5/B14		
								71	63	—
 2.0	5	560	0.88	—	11.3	0.75	2.2	71	63	—
	7.5	373	0.87		17	0.75	1.8			
	10	280	0.86		22	0.75	1.4			
	15	187	0.82		32	0.75	1.0			
	20	140	0.80		30	0.55	1.0			
	25	112	0.76		24	0.37	1.1			
	30	93	0.73		28	0.37	1.3			
	40	70	0.70		24	0.25	1.4			
	50	56	0.65		28	0.25	1.1			
	65	43	0.61		24	0.18	1.2			
80	35	0.58	21	0.13	1.3					
100	28	0.55	24	0.13	1.0	—	56			

GKC 40	$n_1 = 1400$				MOTORI / MOTORS / ENGINE GHA CLASSIC					
	i_n	n_2 [min ⁻¹]	Rd	P_{t0}	T_2 [Nm]	P_1 [kW]	FS'	Input - IEC B5/B14		
								71	63	—
 2.0	5	280	0.87	0.80	16.3	0.55	2.1	71	63	—
	7.5	187	0.85	0.80	24	0.55	1.7			
	10	140	0.83	0.70	31	0.55	1.3			
	15	93	0.79	0.50	30	0.37	1.4			
	20	70	0.76	0.50	38	0.37	1.0			
	25	56	0.72	0.40	31	0.25	1.1			
	30	47	0.68	0.40	35	0.25	1.2			
	40	35	0.64	0.30	38	0.22	1.0			
	50	28	0.59	0.30	36	0.18	1.1			
	65	22	0.54	0.20	31	0.13	1.1			
80	18	0.52	0.20	31	0.11	1.1				
100	14	0.49	0.20	30	0.09	0.9	—	56		

GKC 40	$n_1 = 900$				MOTORI / MOTORS / ENGINE GHA CLASSIC					
	i_n	n_2 [min ⁻¹]	Rd	P_{t0}	T_2 [Nm]	P_1 [kW]	FS'	Input - IEC B5/B14		
								71	63	—
 2.0	5	180	0.85	—	16.7	0.37	2.5	71	63	—
	7.5	120	0.83		25	0.37	2.0			
	10	90	0.81		32	0.37	1.5			
	15	60	0.76		45	0.37	1.1			
	20	45	0.74		39	0.25	1.2			
	25	36	0.69		33	0.18	1.3			
	30	30	0.65		37	0.18	1.3			
	40	23	0.61		33	0.13	1.3			
	50	18	0.55		38	0.13	1.1			
	65	14	0.51		32	0.09	1.2			
80	11	0.48	37	0.09	1.0					
100	9	0.45	29	0.06	1.0	—	56			

GKC 40	$n_1 = 500$				MOTORI / MOTORS / ENGINE GHA CLASSIC					
	i_n	n_2 [min ⁻¹]	Rd	P_{t0}	T_2 [Nm]	P_1 [kW]	FS'	Input - IEC B5/B14		
								71	63	—
 2.0	5	100	0.83	—	7.1	0.09	7.1	71	63	—
	7.5	67	0.81		10	0.09	5.5			
	10	50	0.79		14	0.09	4.4			
	15	33	0.73		19	0.09	3.1			
	20	25	0.70		24	0.09	2.3			
	25	20	0.65		28	0.09	1.7			
	30	17	0.61		31	0.09	1.8			
	40	13	0.57		39	0.09	1.3			
	50	10	0.51		44	0.09	1.2			
	65	8	0.46		52	0.09	0.9			
80	6	0.44	61*	0.09	0.7*					
100	5	0.41	71*	0.09	0.4*	—	56			

* **ATTENZIONE:** la coppia massima utilizzabile [T_{2M}] deve essere calcolata utilizzando il fattore di servizio: $T_{2M} = T_2 \times FS'$

* **WARNING:** Maximum allowable torque [T_{2M}] must be calculated using the following service factor: $T_{2M} = T_2 \times FS'$

* **ACHTUNG:** das max. anwendbare Drehmoment [T_{2M}] muss mit folgendem Betriebsfaktor berechnet werden: $T_{2M} = T_2 \times FS'$

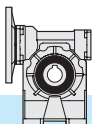

3.10 Dati tecnici

3.10 Technical data

3.10 Technische Daten

GKC 50	$n_1 = 2800$				MOTORI / MOTORS / ENGINE GHA CLASSIC					
	i_n	n_2 [min ⁻¹]	Rd	P_{t0}	T_2 [Nm]	P_1 [kW]	FS'	Input - IEC B5/B14		
								80	71	63
Kg 3.4	5	560	0.89	—	22.8	1.5	1.9			
	7.5	373	0.88		34	1.5	1.5			
	10	280	0.86		44	1.5	1.2			
	15	187	0.84		47	1.1	1.2			
	20	140	0.81		42	0.75	1.4			
	25	112	0.78		50	0.75	1.0			
	30	93	0.75		42	0.55	1.3			
	40	70	0.72		54	0.55	1.0			
	50	56	0.68		43	0.37	1.3			
	65	43	0.64		53	0.37	1.0			
80	35	0.61	41	0.25	1.2					
100	28	0.58	35	0.18	1.3					

GKC 50	$n_1 = 1400$				MOTORI / MOTORS / ENGINE GHA CLASSIC					
	i_n	n_2 [min ⁻¹]	Rd	P_{t0}	T_2 [Nm]	P_1 [kW]	FS'	Input - IEC B5/B14		
								80	71	63
Kg 3.4	5	280	0.87	1.2	26.7	0.9	2.3			
	7.5	187	0.86	1.2	40	0.9	1.8			
	10	140	0.84	1.0	52	0.9	1.4			
	15	93	0.80	0.80	74	0.9	1.0			
	20	70	0.78	0.70	58	0.55	1.3			
	25	56	0.74	0.60	47	0.37	1.4			
	30	47	0.71	0.60	53	0.37	1.2			
	40	35	0.67	0.50	68	0.37	1.0			
	50	28	0.62	0.40	53	0.25	1.3			
	65	22	0.58	0.40	64	0.25	1.0			
80	18	0.54	0.40	53	0.18	1.1				
100	14	0.51	0.30	45	0.13	1.2				

GKC 50	$n_1 = 900$				MOTORI / MOTORS / ENGINE GHA CLASSIC					
	i_n	n_2 [min ⁻¹]	Rd	P_{t0}	T_2 [Nm]	P_1 [kW]	FS'	Input - IEC B5/B14		
								80	71	63
Kg 3.4	5	180	0.85	—	33.8	0.75	2.2			
	7.5	120	0.84		50	0.75	1.6			
	10	90	0.82		66	0.75	1.3			
	15	60	0.78		68	0.55	1.3			
	20	45	0.75		59	0.37	1.5			
	25	36	0.71		70	0.37	1.1			
	30	30	0.67		79	0.37	1.0			
	40	23	0.63		67	0.25	1.1			
	50	18	0.59		78	0.25	1.0			
	65	14	0.54		67	0.18	1.1			
80	11	0.51	56	0.13	1.2					
100	9	0.47	45	0.09	1.3					

GKC 50	$n_1 = 500$				MOTORI / MOTORS / ENGINE GHA CLASSIC					
	i_n	n_2 [min ⁻¹]	Rd	P_{t0}	T_2 [Nm]	P_1 [kW]	FS'	Input - IEC B5/B14		
								80	71	63
Kg 3.4	5	100	0.84	—	14.3	0.18	6.4			
	7.5	67	0.82		21	0.18	4.7			
	10	50	0.80		28	0.18	3.8			
	15	33	0.75		39	0.18	2.7			
	20	25	0.72		50	0.18	2.1			
	25	20	0.68		58	0.18	1.5			
	30	17	0.63		65	0.18	1.5			
	40	13	0.59		81	0.18	1.2			
	50	10	0.54		93	0.18	1.0			
	65	8	0.50		56	0.09	1.5			
80	6	0.46	63	0.09	1.2					
100	5	0.43	74	0.09	0.8					

* **ATTENZIONE:** la coppia massima utilizzabile $[T_{2M}]$ deve essere calcolata utilizzando il fattore di servizio: $T_{2M} = T_2 \times FS'$

* **WARNING:** Maximum allowable torque $[T_{2M}]$ must be calculated using the following service factor: $T_{2M} = T_2 \times FS'$

* **ACHTUNG:** das max. anwendbare Drehmoment $[T_{2M}]$ muss mit folgendem Betriebsfaktor berechnet werden: $T_{2M} = T_2 \times FS'$

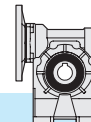

3.10 Dati tecnici

3.10 Technical data

3.10 Technische Daten

GKC 63	$n_1 = 2800$				MOTORI / MOTORS / ENGINE GHA CLASSIC					
	i_n	n_2 [min ⁻¹]	Rd	P_{t0}	T_2 [Nm]	P_1 [kW]	FS'	Input - IEC B5/B14		
Kg 5.7	5	560	0.89	—	45.5	3	1.7	90	80	—
	7.5	373	0.88		68	3	1.3			
	10	280	0.87		89	3	1.1			
	15	187	0.84		95	2.2	1.0			
	20	140	0.83		85	1.5	1.3			
	25	112	0.81		76	1.1	1.2			
	30	93	0.77		87	1.1	1.3	—	71	
	40	70	0.74		111	1.1	1.1			
	50	56	0.70		90	0.75	1.1			
	65	43	0.67		81	0.55	1.2			
	80	35	0.64		65	0.37	1.4			
100	28	0.60	75	0.37	1.1					

GKC 63	$n_1 = 1400$				MOTORI / MOTORS / ENGINE GHA CLASSIC					
	i_n	n_2 [min ⁻¹]	Rd	P_{t0}	T_2 [Nm]	P_1 [kW]	FS'	Input - IEC B5/B14		
Kg 5.7	5	280	0.88	1.8	54	1.8	2.0	90	80	—
	7.5	187	0.87	1.8	80	1.8	1.5			
	10	140	0.85	1.6	105	1.8	1.2			
	15	93	0.81	1.2	125	1.5	1.1			
	20	70	0.80	1.2	120	1.1	1.2			
	25	56	0.77	1.0	118	0.9	1.0			
	30	47	0.73	0.90	134	0.9	1.1	—	71	
	40	35	0.69	0.80	142	0.75	1.1			
	50	28	0.65	0.70	122	0.55	1.0			
	65	22	0.61	0.60	100	0.37	1.2			
	80	18	0.58	0.60	79	0.25	1.4			
100	14	0.53	0.50	91	0.25	1.1				

GKC 63	$n_1 = 900$				MOTORI / MOTORS / ENGINE GHA CLASSIC					
	i_n	n_2 [min ⁻¹]	Rd	P_{t0}	T_2 [Nm]	P_1 [kW]	FS'	Input - IEC B5/B14		
Kg 5.7	5	180	0.87	—	69	1.5	1.9	90	80	—
	7.5	120	0.85		102	1.5	1.4			
	10	90	0.83		133	1.5	1.1			
	15	60	0.79		139	1.1	1.1			
	20	45	0.77		123	0.75	1.4			
	25	36	0.74		109	0.55	1.3			
	30	30	0.70		122	0.55	1.3	—	71	
	40	23	0.66		154	0.55	1.1			
	50	18	0.61		120	0.37	1.2			
	65	14	0.57		98	0.25	1.4			
	80	11	0.54		115	0.25	1.1			
100	9	0.50	95	0.18	1.2					

GKC 63	$n_1 = 500$				MOTORI / MOTORS / ENGINE GHA CLASSIC					
	i_n	n_2 [min ⁻¹]	Rd	P_{t0}	T_2 [Nm]	P_1 [kW]	FS'	Input - IEC B5/B14		
Kg 5.7	5	100	0.85	—	20	0.25	8.3	90	80	—
	7.5	67	0.83		30	0.25	5.9			
	10	50	0.81		39	0.25	4.7			
	15	33	0.76		55	0.25	3.4			
	20	25	0.74		71	0.25	2.8			
	25	20	0.71		85	0.25	1.9			
	30	17	0.65		94	0.25	2.1	—	71	
	40	13	0.62		118	0.25	1.7			
	50	10	0.56		135	0.25	1.2			
	65	8	0.52		163	0.25	1.0			
	80	6	0.50		137	0.18	1.1			
100	5	0.45	77	0.09	1.6					

* **ATTENZIONE:** la coppia massima utilizzabile $[T_{2M}]$ deve essere calcolata utilizzando il fattore di servizio: $T_{2M} = T_2 \times FS'$

* **WARNING:** Maximum allowable torque $[T_{2M}]$ must be calculated using the following service factor: $T_{2M} = T_2 \times FS'$

* **ACHTUNG:** das max. anwendbare Drehmoment $[T_{2M}]$ muss mit folgendem Betriebsfaktor berechnet werden: $T_{2M} = T_2 \times FS'$

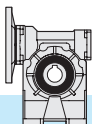

3.10 Dati tecnici

3.10 Technical data

3.10 Technische Daten

GKC 75 Kg 9.5	n₁ = 2800				MOTORI / MOTORS / ENGINE GHA CLASSIC													
	i _n	n ₂ [min ⁻¹]	Rd	P _{t0}	T ₂ [Nm]	P ₁ [kW]	FS'	Input - IEC B5/B14										
								112	100	90	80							
	7.5	373	0.89	—	125	5.5	1.0	112	100	90	—	—						
	10	280	0.88		120	4	1.2											
	15	187	0.85		131	3	1.2											
	20	140	0.84		171	3	1.0											
	25	112	0.82		154	2.2	1.0											
	30	93	0.78		120	1.5	1.4											
	40	70	0.75		154	1.5	1.2											
	50	56	0.73		136	1.1	1.2											
	65	43	0.69		114	0.75	1.4											
	80	35	0.66		135	0.75	1.1											
	100	28	0.62		159	0.75	0.8											
													—			80	71	
																	—	—
																	71	71

GKC 75 Kg 9.5	n₁ = 1400				MOTORI / MOTORS / ENGINE GHA CLASSIC												
	i _n	n ₂ [min ⁻¹]	Rd	P _{t0}	T ₂ [Nm]	P ₁ [kW]	FS'	Input - IEC B5/B14									
								112	100	90	80						
	7.5	187	0.87	2.5	178	4	1.0	112	100	90	—	—					
	10	140	0.86	2.3	176	3	1.1										
	15	93	0.83	1.9	187	2.2	1.1										
	20	70	0.81	1.7	199	1.8	1.1										
	25	56	0.78	1.5	200	1.5	1.0										
	30	47	0.74	1.2	167	1.1	1.3										
	40	35	0.71	1.1	213	1.1	1.1										
	50	28	0.67	1.0	206	0.9	1.0										
	65	22	0.63	0.90	154	0.55	1.3										
	80	18	0.60	0.80	180	0.55	1.0										
	100	14	0.56	0.70	210	0.55	0.8										
													—			80	71
																—	—
																71	71

GKC 75 Kg 9.5	n₁ = 900				MOTORI / MOTORS / ENGINE GHA CLASSIC													
	i _n	n ₂ [min ⁻¹]	Rd	P _{t0}	T ₂ [Nm]	P ₁ [kW]	FS'	Input - IEC B5/B14										
								112	100	90	80							
	7.5	120	0.86	—	205	3	1.0	112	100	90	—	—						
	10	90	0.84		197	2.2	1.2											
	15	60	0.81		231	1.8	1.0											
	20	45	0.78		250	1.5	1.1											
	25	36	0.76		221	1.1	1.1											
	30	30	0.71		249	1.1	1.0											
	40	23	0.67		214	0.75	1.3											
	50	18	0.64		186	0.55	1.3											
	65	14	0.59		151	0.37	1.5											
	80	11	0.56		177	0.37	1.2											
	100	9	0.52		203	0.37	0.9											
														—			80	71
																	—	—
																	71	71

GKC 75 Kg 9.5	n₁ = 500				MOTORI / MOTORS / ENGINE GHA CLASSIC													
	i _n	n ₂ [min ⁻¹]	Rd	P _{t0}	T ₂ [Nm]	P ₁ [kW]	FS'	Input - IEC B5/B14										
								112	100	90	80							
	7.5	67	0.84	—	90	0.75	2.9	112	100	90	—	—						
	10	50	0.82		118	0.75	2.4											
	15	33	0.78		167	0.75	1.7											
	20	25	0.75		216	0.75	1.5											
	25	20	0.72		260	0.75	1.1											
	30	17	0.67		288	0.75	1.1											
	40	13	0.63		265	0.55	1.2											
	50	10	0.59		210	0.37	1.3											
	65	8	0.55		251	0.37	1.0											
	80	6	0.52		197	0.25	1.2											
	100	5	0.47		161	0.18	1.3											
														—			80	71
																	—	—
																	71	71

* **ATTENZIONE:** la coppia massima utilizzabile [T_{2M}] deve essere calcolata utilizzando il fattore di servizio: T_{2M} = T₂ x FS'

* **WARNING:** Maximum allowable torque [T_{2M}] must be calculated using the following service factor : T_{2M} = T₂ x FS'

* **ACHTUNG:** das max. anwendbare Drehmoment [T_{2M}] muss mit folgendem Betriebsfaktor berechnet werden: T_{2M} = T₂ x FS'

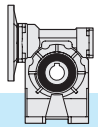

3.10 Dati tecnici

3.10 Technical data

3.10 Technische Daten

GKC 89	$n_1 = 2800$				MOTORI / MOTORS / ENGINE GHA CLASSIC					
	i_n	n_2 [min ⁻¹]	Rd	P_{t0}	T_2 [Nm]	P_1 [kW]	FS'	Input - IEC B5/B14		
								112 100	90	—
Kg 16.4	7.5	373	0.89	—	171	7.5	1.2			
	10	280	0.88		165	5.5	1.3			
	15	187	0.86		241	5.5	1.0			
	20	140	0.84		230	4	1.2			
	25	112	0.83		212	3	1.2			
	30	93	0.79		243	3	1.1			
	40	70	0.77		230	2.2	1.3			
	50	56	0.74		278	2.2	1.0			
	65	43	0.71		235	1.5	1.1			
	80	35	0.68		205	1.1	1.2			
	100	28	0.64		163	0.75	1.3			

GKC 89	$n_1 = 1400$				MOTORI / MOTORS / ENGINE GHA CLASSIC					
	i_n	n_2 [min ⁻¹]	Rd	P_{t0}	T_2 [Nm]	P_1 [kW]	FS'	Input - IEC B5/B14		
								112 100	90	—
Kg 11.5	7.5	187	0.88	3.0	247	5.5	1.2			
	10	140	0.86	2.5	236	4	1.3			
	15	93	0.84	2.2	256	3	1.2			
	20	70	0.82	2.0	334	3	1.1			
	25	56	0.80	1.8	299	2.2	1.1			
	30	47	0.76	1.5	340	2.2	1.0			
	40	35	0.72	1.3	355	1.8	1.1			
	50	28	0.69	1.1	353	1.5	1.0			
	65	22	0.65	1.0	317	1.1	1.0			
	80	18	0.63	1.0	309	0.9	1.0			
	100	14	0.58	0.80	217	0.55	1.2			

GKC 89	$n_1 = 900$				MOTORI / MOTORS / ENGINE GHA CLASSIC					
	i_n	n_2 [min ⁻¹]	Rd	P_{t0}	T_2 [Nm]	P_1 [kW]	FS'	Input - IEC B5/B14		
								112 100	90	—
Kg 11.5	7.5	120	0.86	—	206	3	1.7			
	10	90	0.85		270	3	1.3			
	15	60	0.82		286	2.2	1.3			
	20	45	0.79		371	2.2	1.1			
	25	36	0.77		369	1.8	1.0			
	30	30	0.73		416	1.8	1.0			
	40	23	0.69		440	1.5	1.0			
	50	18	0.66		384	1.1	1.0			
	65	14	0.62		319	0.75	1.1			
	80	11	0.59		274	0.55	1.2			
	100	9	0.54		313	0.55	1.0			

GKC 89	$n_1 = 500$				MOTORI / MOTORS / ENGINE GHA CLASSIC					
	i_n	n_2 [min ⁻¹]	Rd	P_{t0}	T_2 [Nm]	P_1 [kW]	FS'	Input - IEC B5/B14		
								112 100	90	—
Kg 11.5	7.5	67	0.84	—	91	0.75	4.7			
	10	50	0.83		118	0.75	3.7			
	15	33	0.79		169	0.75	2.7			
	20	25	0.76		219	0.75	2.3			
	25	20	0.74		265	0.75	1.7			
	30	17	0.68		294	0.75	1.6			
	40	13	0.65		371	0.75	1.4			
	50	10	0.61		439	0.75	1.1			
	65	8	0.57		388	0.55	1.1			
	80	6	0.54		305	0.37	1.3			
	100	5	0.49		344	0.37	1.0			

* **ATTENZIONE:** la coppia massima utilizzabile $[T_{2M}]$ deve essere calcolata utilizzando il fattore di servizio: $T_{2M} = T_2 \times FS'$

* **WARNING:** Maximum allowable torque $[T_{2M}]$ must be calculated using the following service factor: $T_{2M} = T_2 \times FS'$

* **ACHTUNG:** das max. anwendbare Drehmoment $[T_{2M}]$ muss mit folgendem Betriebsfaktor berechnet werden: $T_{2M} = T_2 \times FS'$

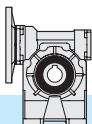

3.11 Momenti d' inerzia [Kg·cm²]
(riferiti all'albero veloce in entrata)

3.11 Moments of inertia [Kg·cm²]
(referred to input shaft)

3.11 Trägheitsmoment [Kg·cm²]
(bez. Antriebswelle)

	i_n	GKC	
		B5 - B14	
		IEC 56	IEC 63
GK30	5	0.130	0.127
	7.5	0.112	0.109
	10	0.103	0.100
	15	0.097	0.094
	20	0.095	0.092
	25	0.094	0.091
	30	0.093	0.090
	40	0.093	0.090
	50	0.092	0.089
	65	0.079	-
	80	0.079	-
	100	0.078	-

	i_n	GKC		
		B5 - B14		
		IEC 56	IEC 63	IEC 71
GK40	5	-	0.391	0.463
	7.5	-	0.321	0.356
	10	-	0.272	0.347
	15	-	0.266	0.340
	20	-	0.263	0.338
	25	-	0.262	0.337
	30	-	0.262	0.337
	40	-	0.261	0.336
	50	0.182	0.261	-
	65	0.182	0.261	-
	80	0.182	0.261	-
	100	0.182	0.261	-

	i_n	GKC		
		B5 - B14		
		IEC 63	IEC 71	IEC 80
GK50	5	-	0.922	1.046
	7.5	-	0.684	0.935
	10	-	0.602	0.853
	15	-	0.543	0.794
	20	-	0.523	0.774
	25	-	0.513	0.764
	30	-	0.508	0.759
	40	0.315	0.503	0.755
	50	0.313	0.501	-
	65	0.311	0.499	-
	80	0.310	0.498	-
	100	0.309	0.498	-

	i_n	GKC		
		B5 - B14		
		IEC 71	IEC 80	IEC 63
GK63	5	-	2.431	2.671
	7.5	-	1.949	2.269
	10	-	1.744	2.063
	15	-	1.597	1.916
	20	-	1.545	1.864
	25	-	1.514	1.833
	30	-	1.508	1.828
	40	0.966	1.495	-
	50	0.959	1.488	-
	65	0.955	1.484	-
	80	0.953	1.482	-
	100	0.952	1.481	-

	i_n	GKC			
		B5 - B14			
		IEC 71	IEC 80	IEC 90	IEC 100-112
GK75	7.5	-	-	3.712	4.462
	10	-	-	3.234	3.984
	15	-	-	2.893	3.643
	20	-	-	2.774	3.523
	25	-	-	2.709	3.458
	30	1.615	1.575	2.689	3.438
	40	-	1.573	2.659	-
	50	-	1.570	2.642	-
	65	1.609	1.569	2.633	-
	80	1.605	1.565	2.629	-
	100	1.602	1.562	2.626	-

	i_n	GKC		
		B5 - B14		
		IEC 80	IEC 90	IEC 100-112
GK89	7.5	-	6.898	7.671
	10	-	5.875	6.648
	15	-	5.144	5.917
	20	-	3.398	5.661
	25	-	3.256	5.520
	30	-	3.215	5.479
	40	-	3.151	-
	50	-	3.115	-
	65	2.024	3.096	-
	80	2.014	3.087	-
	100	2.008	3.080	-

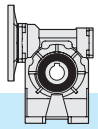

3.12 Dimensioni

3.12 Dimensions

3.12 Abmessungen

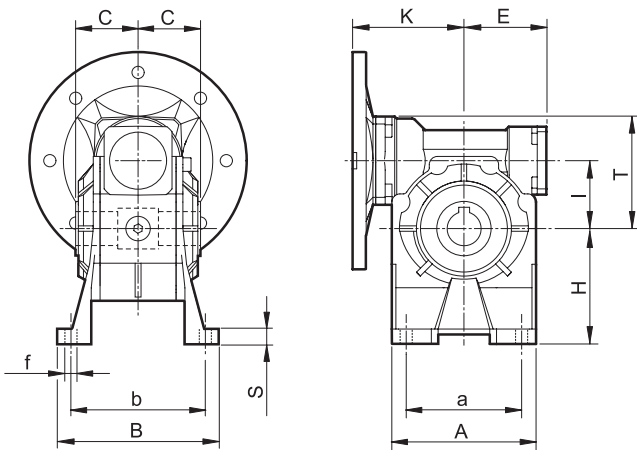

GKC..A

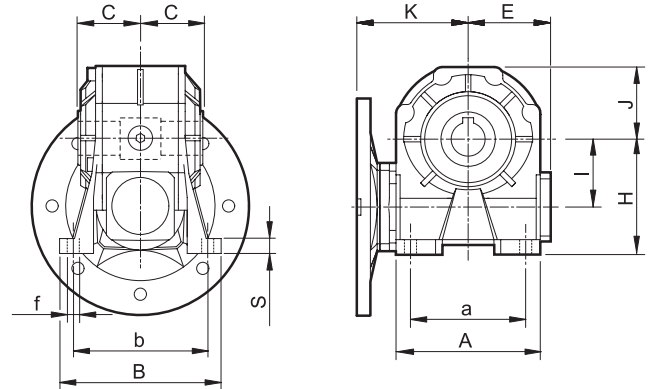

GKC..B

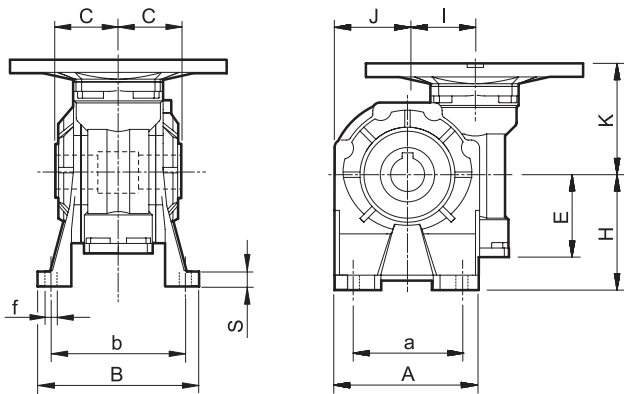

GKC..V

	30	40	50	63	75	89
b2	5	6	8	8	8	10
C	31.5	39	46	56	60	70
D2 H8	14	18	25	25	28	35
E	41	51	60	71	85	103
G h8	55	60	70	80	95	110
I	31.5	40	50	63	75	90
J	37.5	43.5	53.5	64	78	100
K	57	75	82	97	114 - 112 ⁽¹⁾	122
M	M6x8	M6x10	M8x10	M8x14	M8x14	M10x18
Pp	29	36.5	43.5	53	57	67
R	65	75	85	95	115	130
T	52.5	68.5	82.5	100.5	116.5	131.5
t2	16.3	20.8	28.3	28.3	31.3	38.3
X	1.5	1.5	1.5	2	2	2

(1): Solo per PAM 71B14 / Only for PAM 71B14 / Nur PAM 71B14

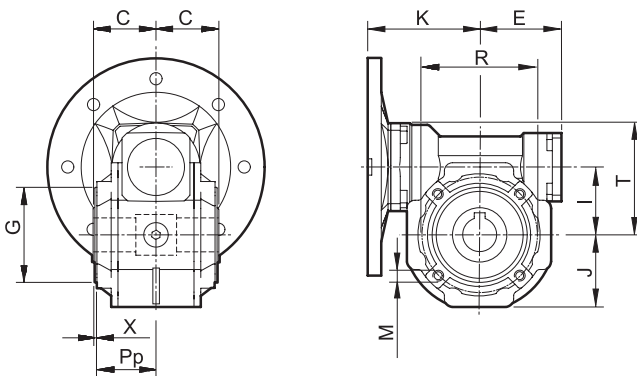

Flangia pendolare / Side cover for shaft mounting / Aufsteckflansch

	Piedi Feet Fuß	30	40	50	63	75	89
A	1	67	86.5	106	127.5	155.5	190
	2	67	86.5	106			190
a	1	40-52	70	63-85	95	120	140
	2	40-52	52	63-85			140
B	1	78	98	119	136	140	168
	2	78	98	119			168
b	1	66	84	99	111	115	140
	2	66	81	99			146
f	1	6.5	7	9	11	11	13
	2	6.5	8.5	9			11
H	1	52	71	85	100	115	135
	2	55	72	82			142
S	1	5	9	11	12	12	14
	2	8	10	8			14

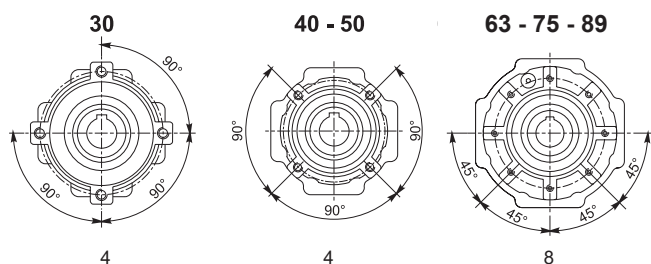

Fiori / Holes / Bohrungen Fiori / Holes / Bohrungen Fiori / Holes / Bohrungen

GKC..P

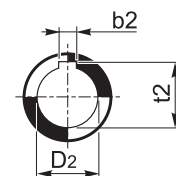

Albero uscita cavo
Hollow output shaft
Abtriebshohlwelle

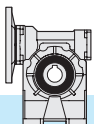

3.12 Dimensioni

3.12 Dimensions

3.12 Abmessungen

Flangia uscita / Output flange / Abtriebsflansch

Vista da A / View from A / Ansicht von A

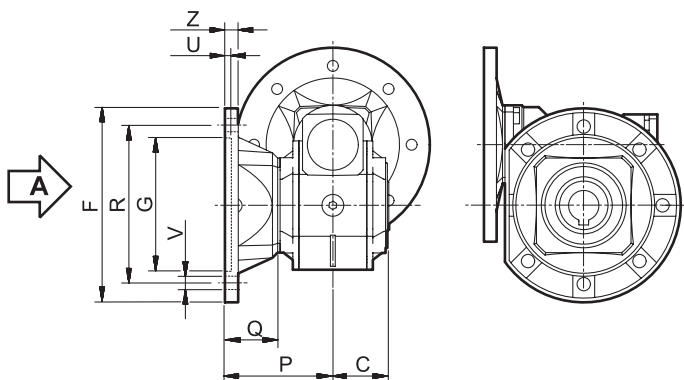

GKC..F

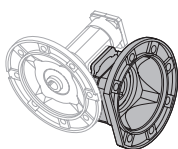

F...D
Standard

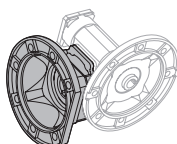

F...S

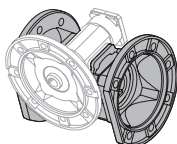

F...2

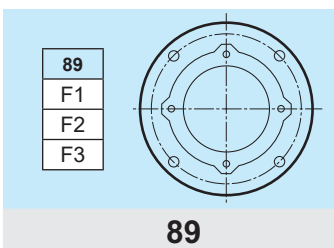
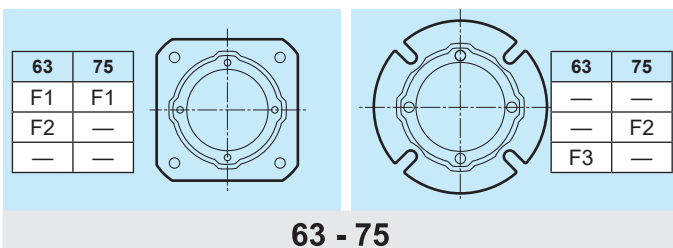
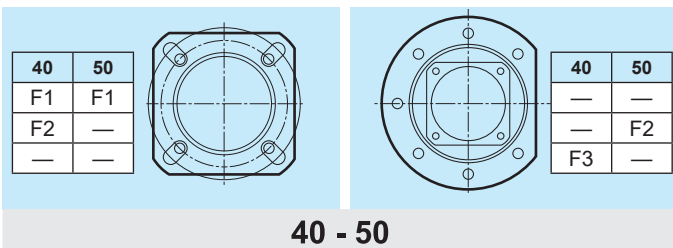
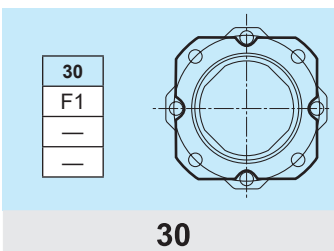

GKC	C	F		G H8	P	Q	R	U	V			Z
											Ø	
30	31.5		66	50	54.5	23	68	4	n° 4		6.5	6
40	39		85	60	67	28	75-90	4	n° 4		9	8
			85	60	97	58	75-90	4	n° 4		9	8
			140	95	80	41	115	5		n° 7	9	10
50	46		94	70	90	44	85-100	5	n° 4		11	10
			160	110	89	43	130	5		n° 7	11	11
63	56		142	115	82	26	150	5	n° 4		11	11
			142	115	112	56	150	5	n° 4		11	11
			160	110	80.5	24.5	130	5	n° 4		11	12
75	60		160	130	111	51	165	5	n° 4		13	12
			160	110	90	30	130	6	n° 4		11	13
89	70		200	152	111	41	175	5	n° 4		13	12
			200	152	151	81	175	5	n° 4		13	13
			200	130	110	40	165	6	n° 4		11	11

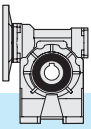

GK

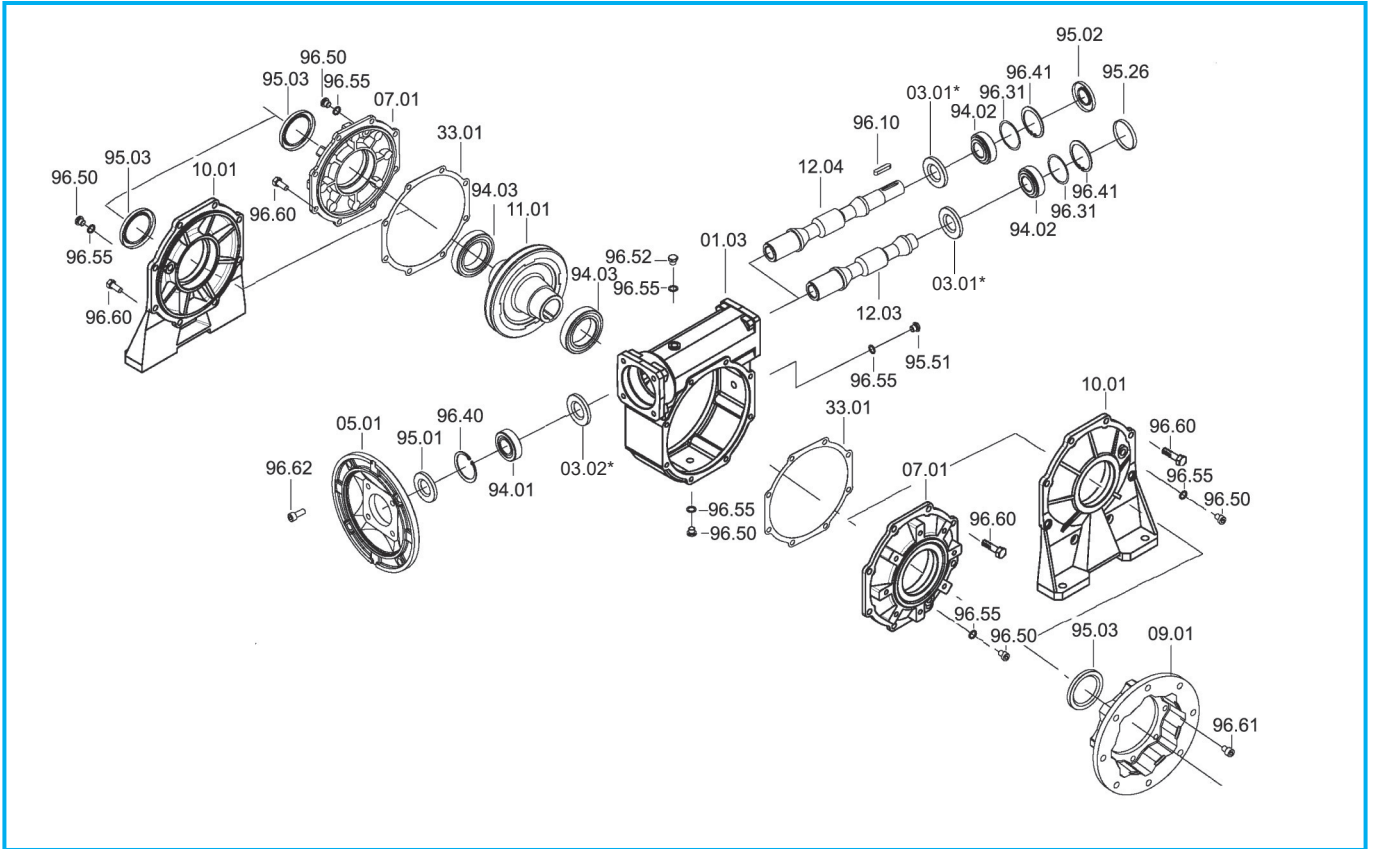

GKC	IEC	Cuscinetti / Bearings / Lager			Anelli di tenuta / Oilseals Öldichtungen			Cappellotto / Closed oil seal Geschlossene Öldichtung
		94.01	94.02	94.03	95.01	95.02	95.03	95.26
30	56	61804 (20x32x7)	6000 10x26x8	6005 25x47x12	20/32/7	10/26/7	25/40/7	ø 26x7
	63	61804 (20x32x7)			20/32/7			
40	56	6303 (17x47x14)	6201 12x32x10	6006 30x55x13	17/47/7	12/32/7	30/47/7	ø 32x7
	63	6204 (20x47x14)			30x55x17			
	71	6005 (25x47x12)			25/47/7			
50	63	6204 (20x47x14)	6203 17x40x12	6008 40x68x15	20/47/7	17/40/7	40/62/8	ø 40x7
	71	6005 (25x47x12)			25/47/7			
	80	6006 (30x55x13)			30/55/7			
63	71	6305 (25x62x17)	6204 C3 20x47x14	6008 40x68x15	25/62/7	20/47/7	40/62/8	ø 47x7
	80	6206 (30x62x16)			30/62/7			
	90	6007 (35x62x14)			35/62/7			
75	71	6206 (30x62x16)	6205 C3 25x52x15	6010 50x80x16	30/62/7	25/52/7	50/72/8	ø 52x7
	80	6206 (30x62x16)			30/62/7			
	90	6007 (35x62x14)			35/62/7			
	100/112	6008 (40x68x15)			40/68/10			
89	80	6206 (30x62x16)	6205 C3 25x52x15	6010 50x80x16	30/62/7	25/52/7	50/72/8	ø 52x7
	90	6007 (35x62x14)			35/62/7			
	100/112	6008 (40x68x15)			40/68/10			

*: Solo per GK63, 75, 89 / Only for GK63, 75, 89 / Nur für GK63, 75, 89.

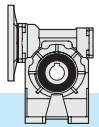

3.14 Lista parti di ricambio

In fase di ordine delle parti di ricambio, specificare sempre n° particolare (vedi disegno esploso), data (1), n° codice (2) e n° variante (3). (Vedi targhetta).

3.14 Spare parts list

When ordering a spare part, the spare part number (see exploded technical drawing), the date (1), the code number (2) and the variant number (3) should always be reported. (See plate)

3.14 Ersatzteilliste

Bei der Bestellung von Ersatzteilen sind Ersatzteilnummer (s. Explosionszeichnung), Datum (1), Artikelnummer (2) und Variantennummer (3) anzugeben. (s. Schild)

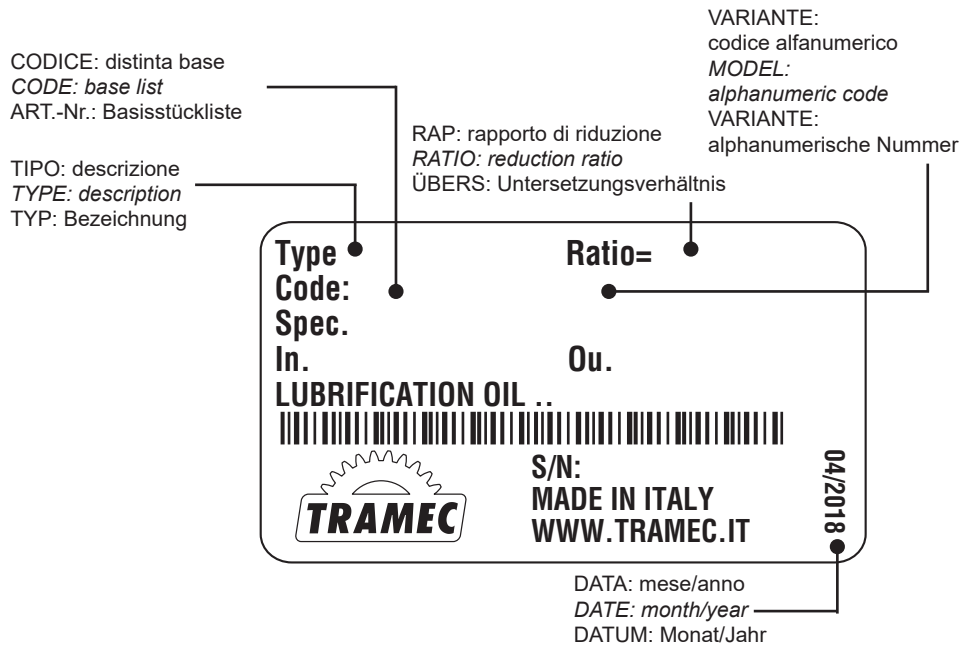

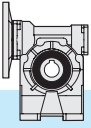

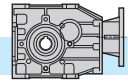

4.0	RIDUTTORE AD ASSI ORTOGONALI GT	BEVEL HELICAL GEARBOX GT	KEGELSTIRNRADGETRIEBE GT
4.1	Caratteristiche	<i>Characteristics</i>	Merkmale 54
4.2	Designazione	<i>Designation</i>	Bezeichnung 55
4.3	Rendimento	<i>Efficiency</i>	Wirkungsgrad 56
4.4	Gioco angolare	<i>Backlash</i>	Winkelspiel 56
4.5	Sensi di rotazione alberi	<i>Direction of shaft rotation</i>	Drehrichtungen der Wellen 56
4.6	Carichi radiali e assiali	<i>Radial and axial loads</i>	Radial- und Axialbelastungen 57
4.7	Lubrificazione	<i>Lubrication</i>	Schmierung 58
4.8	Posizione morsettiera	<i>Terminal board position</i>	Lage des Klemmenkastens 59
4.9	Velocità in entrata	<i>Input speed</i>	Antriebsdrehzahl 59
4.10	Potenza termica	<i>Thermal power</i>	Thermische Leistung 60
4.11	Dati tecnici	<i>Technical data</i>	Technische Daten 61
4.12	Momenti d'inerzia	<i>Moments of inertia</i>	Trägheitsmoment 62
4.13	Dimensioni	<i>Dimensions</i>	Abmessungen 64
4.14	Accessori	<i>Accessories</i>	Zubehör 67
4.15	Lista parti di ricambio	<i>Spare parts list</i>	Ersatzteilliste 67

GHA - CLASSIC

La serie CLASSIC costituisce la serie standard all'interno della gamma di riduttori GHA.

Le speciali caratteristiche NANOTECHNOLOGICHE del rivestimento della carcassa e il suo design esterno, certificato HACCP, rendono i riduttori di questa serie particolarmente adatti per le applicazioni in ambienti ALIMENTARE e FARMACEUTICO.

Il riduttore non è adatto al contatto con gli alimenti.

GHA - CLASSIC

The CLASSIC series is the standard series within the range of GHA reducers.

The special NANOTECHNOLOGICAL properties of the case coating and its external construction, certified by HACCP, make the gearboxes of this series particularly suitable for applications in FOOD and PHARMACEUTICAL environments.

The reducer is not suitable for contact with food.

GHA - CLASSIC

Die Serie CLASSIC ist die Standardbaureihe innerhalb der Produktpalette der GHA-behandelten Getriebe.

Durch die spezielle NANOTECHNOLOGISCHEN Eigenschaften der Gehäusebeschichtung und das Design des Gehäuses (zertifiziert durch HACCP), sind die Getriebe dieser Serie besonders geeignet für den Einsatz in LEBENSMITTEL- und PHARMAZEUTISCHER Umgebung.

Das Getriebe ist nicht für den Kontakt mit Lebensmitteln geeignet.

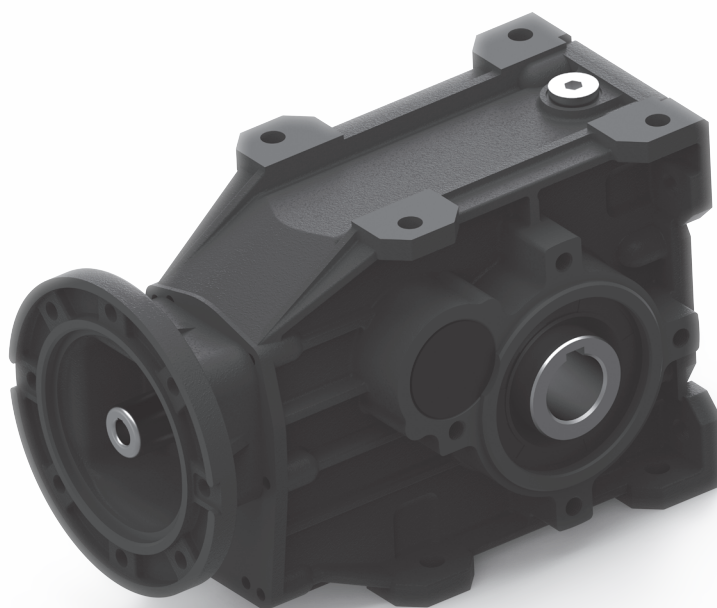

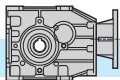

4.1 Caratteristiche

- Costruiti in 3 grandezze a 2 e a 3 riduzioni.
- È previsto un tipo di entrata: con predisposizione attacco motore (campana e manicotto)
- Il corpo riduttore in lega di alluminio, GAlSi9Cu1 UNI7369/3, abbondantemente nervato all'interno e all'esterno per garantire la rigidità, è lavorato su tutti i piani per consentire un facile posizionamento.
- Gli ingranaggi sono costruiti in acciaio legato da cementazione e sottoposti a trattamento di cementazione e tempra. In particolare, la prima riduzione è costituita da due ingranaggi conici ipoidi con profilo accuratamente rodato, in acciaio 16NiCr4 o 18NiCrMo5 cementati e temprati. Gli ingranaggi cilindrici, a dentatura elicoidale, sono costruiti in acciaio 16NiCr4, 18NiCrMo5 o 20MnCr5 UNI EN 10084 cementati e temprati, rettificati entro la classe di qualità 6 della DIN 3962.
- Le carcasce e flange in alluminio sono sabbiato e trattate con tecnologia G.H.A. ®
- L'albero lento cavo di serie in acciaio INOX AISI 316, la possibilità di montare una flangia uscita su uno o entrambi i fianchi laterali esaltano la versatilità di questi riduttori facilitandone l'installazione.

4.1 Characteristics

- *Built in 3 sizes with 2 and 3 reduction stages.*
- *One input type available and suitable for the motor mounting (bell and sleeve).*
- *The gear unit casing is in aluminum alloy GAlSi9Cu1 UNI7369/3, internally and externally ribbed to guarantee rigidity and it is machined on all surfaces for easy positioning.*
- *The gears are built in casehardened compound steel and have undergone case-hardening and quench-hardening treatments. In particular, the first stage consists of two GLEASON spiral bevel gears with precise ground profile, in 16NiCr4 or 18NiCrMo5 case hardened and quench-hardened steel. The helical spur gears are built in 16NiCr4, 18NiCrMo5 or 20MnCr5 UNI EN 10084, quench – hardened and case-hardened steel, ground according and within Class 6 quality DIN 3962.*
- *Aluminum housings and flanges are sandblasted and treated in accordance with G.H.A. ® technology.*
- *The Stainless Steel AISI 316 hollow shaft together with the possibility to mount an output flange on one or both sides, enhance the versatility of these gearboxes, making it easy to install.*

4.1 Merkmale

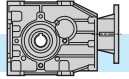

- Erhältlich in 3 Baugrößen zu je 2 und 3 Untersetzungsstufen.
- Grundausführung mit freier Eintriebswelle; Motoranbau via Glocke und Kupplung
- Das Getriebegehäuse besteht aus einer Aluminium Legierung (GAlSi-9Cu1 UNI7369/3) und ist mit Rippen versehen, die die gewünschte Steifheit garantieren. Die Bearbeitung aller Oberflächen ermöglicht eine exakte Positionierung.
- Die Zahnräder bestehen aus gehärtetem Stahl und sind zusätzlich oberflächengehärtet. Die erste Stufe besteht aus zwei spiralverzahnten GLEASON – Kegelrädern in 16NiCr4 oder 18NiCr5. Die Stirnradstufen sind schrägverzahnt und in 16NiCr4, 18NiCrMo5 oder 20MnCr5 UNI EN 10084 in der Qualitäts-Klasse 6 DIN 3962 ausgeführt.
- Die Aluminiumgehäuse und Flansche sind sandgestrahlt und mit G.H.A. ® - Technik behandelt.
- Die rostfreie Edelstahl-Hohlwelle AISI 316, mit der Möglichkeit, Ausgangsflansche an einer oder beiden Seiten zu montieren, erhöht die Vielseitigkeit der Getriebe und erleichtert die Montage.



4.2 Designazione

4.2 Designation

4.2 Bezeichnung

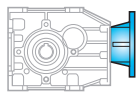
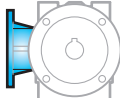
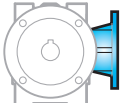
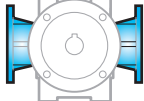
Riduttore Gearbox Getriebe	Tipo entrata Input type Antriebsart	Grandezza Size Größe	Rotismo Gearing Räderwerk	Rapporto rid. Ratio Untersetzungsverhältnis	Predisposiz. Motor coupling Motoranschluss	Esecuzione Execution Ausführung	Posizione di montaggio Mounting position Baulage	Albero uscita cavo Hollow output shaft Abtriebshohlwelle	Flangia uscita Output flange Abtriebsflansch
GT	F	63	B	10	P.A.M.	O	B3	25	FLS
Riduttore ad assi ortogonali Bevel helical gearbox Kegelstirnradgetriebe		56 63 75	B 	$8 + \frac{1}{5} = 315$	56 ÷ 100	 O	B3 B6 B7 B8 VA VB	v. pag. dimensioni See page dimensions siehe Seite Abmessungen	 FLS  FLD  FL2

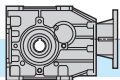

4.3 Rendimento

Il valore del rendimento dei riduttori può essere stimato con sufficiente approssimazione in base al numero di riduzioni, trascurando le variazioni non significative attribuibili alle varie grandezze e rapporti.

4.3 Efficiency

The efficiency value of the gear units can be estimated sufficiently well on the basis of the number of reduction stages, ignoring non-significant variations which can be attributed to the various sizes and ratios.

4.3 Wirkungsgrad

Der Wirkungsgrad des Getriebes kann mit ausreichender Annäherung aufgrund der Anzahl der Untersetzungsstufen ermittelt werden. Dabei können die unwesentlichen Veränderungen, die auf die verschiedenen Grössen und Untersetzungsverhältnisse zurückzuführen sind, ausser Acht gelassen werden.

η	GTF..B	GTF..C
	0.95	0.93

4.4 Gioco angolare

Misurato bloccando l'albero entrata, e ruotando l'albero uscita nelle due direzioni applicando la coppia strettamente necessaria a creare il contatto tra i denti degli ingranaggi, al massimo pari al 2% della coppia nominale (T_{2M}).

4.4 Backlash

Angular backlash measured after having blocked the input shaft by rotating output shaft in both directions and applying the torque which is strictly necessary to create a contact between the teeth of the gears. The applied torque should be at most 2% of the max. torque (T_{2M}).

4.4 Winkelspiel

Nachdem die Antriebswelle blockiert worden ist, darf das Winkelspiel auf die Abtriebswelle bemessen werden. Dabei soll die Antriebswelle in beiden Richtungen gedreht werden und ein Drehmoment ausgeübt werden, das zur Entstehung eines Kontaktes zwischen den Zähnen genuegt. Das ausgeübte Drehmoment soll höchstens 2% des max. von Getrieben garantierten Drehmoment (T_{2M}) sein.

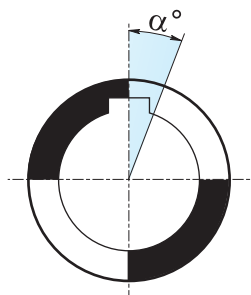

	GT	
	Gioco angolare massimo Maximum Backlash maximales Winkelspiel	
2 stadi/stages/stufig	20'	
3 stadi/stages/stufig	20'	

4.5 Senso di rotazione

4.5 Direction of rotation

4.5 Drehrichtung

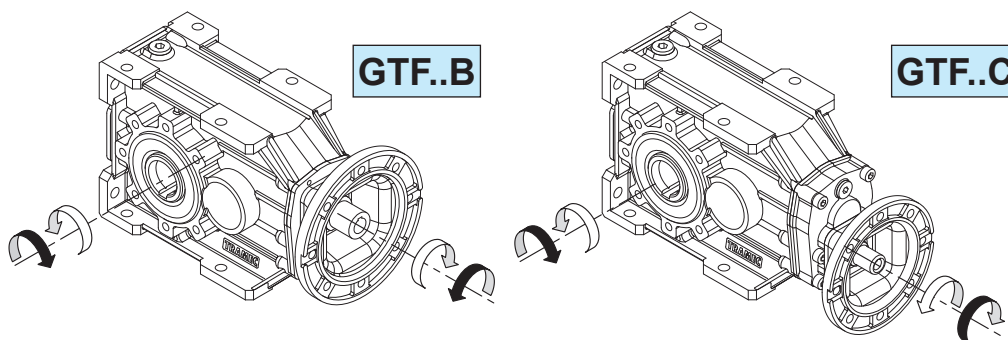

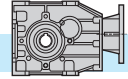

4.6 Carichi radiali

Carichi radiali Fr_2 e assiali Fa_2 sull'albero uscita [N]

Se il carico radiale sull'albero non è applicato a metà della sporgenza dell'albero, il valore del carico ammissibile deve essere valutato utilizzando la formula che si riferisce ad Fry_2 , in cui i valori di a , b e Fr_2 sono riportati nelle tabelle relative ai carichi radiali.

Nel caso di alberi bisporgenti il valore del carico applicabile a ciascuna estremità è uguale ai 2/3 del valore di tabella, purchè i carichi applicati siano uguali di intensità e direzione ed agiscano nello stesso senso. Diversamente contattare il servizio tecnico.

4.6 Radial load

Fr_2 radial loads and Fa_2 axial loads on the output shaft [N]

Should the radial load affect the shaft not at the half-way point of its projection but at a different point, the value of the admissible load has to be calculated using the Fry_2 formula: a , b and Fr_2 values are reported in the radial load tables.

With regard to double-projecting shafts, the load applicable at each end is 2/3 of the value given in the table, on condition that the applied loads feature same intensity and direction and that they act in the same direction.

Otherwise please contact the technical department.

4.6 Radialbelastungen

Fr_2 Radialbelastungen und Fa_2 Axialbelastungen auf die Abtriebswelle [N]

Falls die Radialbelastungen nicht in dem Mittelpunkt der herausragenden Welle sondern in einem anderen Punkt wirken, soll die zulässige Belastung mit der Formel bezüglich Fry_2 kalkuliert werden: a , b und Fr_2 Werte sind aus der Tabelle der Radialbelastungen zu entnehmen.

Bei doppelseitigen Abtriebswellen ist die Belastung, die an jedem Ende anwendbar ist, 2/3 des in der Tabelle angegebenen Wertes unter der Bedingung, dass die Belastungen die selbe Stärke und Richtung aufweisen und dass sie in der selben Richtung wirken. Andernfalls muß mit dem technischen Büro Rücksprache gehalten werden.

I carichi radiali indicati nelle tabelle si intendono applicati a metà della sporgenza dell'albero e sono riferiti ai riduttori operanti con fattore di servizio 1.

The radial loads indicated in the chart are considered to be applied at the half-way point of the shaft projection, and refer to gear units operating with service factor 1.

Die Radialbelastungen, die in den Tabellen angegeben werden, gelten für Ansatzpunkte in der Mitte des herausragenden Wellenteils und für Getriebe mit Betriebsfaktor 1.

		GT 56B		GT 63B		GT 75B				GT 56C		GT 63C		GT 75C	
ALBERO USCITA / OUTPUT SHAFT / ABTRIEBSWELLE ($n_1 = 1400 \text{ min}^{-1}$)															
in	a = 106	b = 81	a = 121	b = 93.5	a = 106	b = 81	in	a = 106	b = 81	a = 121	b = 93.5	a = 121	b = 93.5		
	Fr_2	Fa_2	Fr_2	Fa_2	Fr_2	Fa_2		Fr_2	Fa_2	Fr_2	Fa_2	Fr_2	Fa_2		
8	1300	260	1500	300	2500	500	40	2300	460	2500	500	—	—		
10	1300	260	1500	300	2500	500	50	2300	460	2500	500	3500	700		
12.5	1300	260	1500	300	2500	500	63	2300	460	2500	500	3500	700		
16	1800	360	2000	400	2500	500	80	2800	560	3000	600	3500	700		
20	1800	360	2000	400	3000	600	100	2800	560	3000	600	4000	800		
25	1800	360	2000	400	3000	600	125	2800	560	3000	600	4000	800		
31.5	1800	360	2000	400	3000	600	160	2800	560	3000	600	4000	800		
40	2300	460	2500	500	3500	700	200	3000	600	3500	700	4500	900		
50	2300	460	2500	500	3500	700	250	3000	600	3500	700	4500	900		
63	—	—	2500	500	—	—	315	—	—	3500	700	—	—		

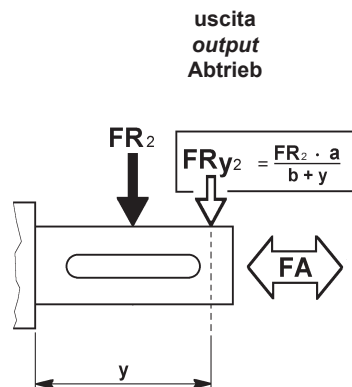

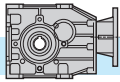

4.7 Lubrificazione

I riduttori ad assi ortogonali GTF56, GTF63 e GTF75 sono lubrificati a vita con olio alimentare OLIO FUCHS CASSIDA FLUID 320. Il grasso lubrificante applicato sui cuscinetti è compatibile con uso alimentare ed è il FUCHS CASSIDA GREASE HTS2.

Si raccomanda di precisare sempre la posizione di montaggio desiderata in fase di ordine.

Nelle posizioni di montaggio in cui sono presenti cuscinetti posti al di sopra del livello dell'olio lubrificante è prevista l'applicazione di grasso speciale su tali cuscinetti per migliorarne la lubrificazione. E' possibile dotare gli stessi cuscinetti di un anello metallico (nylos) con la funzione di contenimento del grasso e, di conseguenza, di prolungare l'effetto nel tempo. Questa soluzione viene fornita su specifica richiesta.

4.7 Lubrication

Bevel helical gearboxes type GTF56, GTF63 and GTF75 are lubricated for life with FUCHS CASSIDA FLUID 320 oil. The grease FUCHS CASSIDA GREASE HTS2 applied on the bearings is compatible with food use.

The mounting position should always be specified while ordering the gearbox.

Depending on the mounting position the bearings may be lodged above the lubricant level. In this case, it is necessary to apply special grease on the bearings to improve their lubrication. A metallic ring (nylos-ring) can be fitted on the bearings, it keeps the grease in place thus prolonging the action. It is supplied on specific request.

4.7 Schmierung

Die Kegelstirnradgetriebe Typ GTF56, GTF63 und GTF75 werden mit FUCHS CASSIDA FLUID 320 Öl geschmiert. Das auf die Lager aufgebrauchte Fett, FUCHS CASSIDA GREASE HTS2, ist geeignet für den Einsatz in der Lebensmittelindustrie.

Bei der Bestellung ist immer die gewünschte Einbaulage anzugeben.

Abhängig von der Einbaulage kann es sein, dass die Lager über dem Ölstand liegen. In diesem Fall wird Sonderfett auf die Lager aufgetragen, um deren Schmierung zu gewährleisten. Auf Wunsch kann ein Metallring (Nilos – Ring) für die Lager geliefert werden. Dieser hält das Fett im Lager und verlängert die Lebensdauer.

Posizione di montaggio e quantità di lubrificante (litri)

I quantitativi di olio riportati nelle varie tabelle sono indicativi e riferiti alle posizioni di lavoro indicate e considerando le condizioni di funzionamento a temperatura ambiente e velocità in ingresso di 1400 min⁻¹. Per condizioni di lavoro diverse da quelle sopra riportate contattare il servizio tecnico.

Mounting positions and lubricant quantity (liters)

The oil quantities stated in the tables are approximate values and refer to the indicated working positions, considering operating conditions at ambient temperature and an input speed of 1400 min⁻¹. Should the operating conditions be different, please contact the technical service.

Montageposition und Ölmenge (liter)

Die in der Tabellen angegebenen Daten sind Richtwerte. Die Ölmengen beziehen sich auf die angegebenen Betriebspositionen. Dabei wird den Betrieb bei Umgebungstemperatur und Antriebsdrehzahl von 1400 min⁻¹ berücksichtigt. Falls die Betriebsbedingungen anders sind, dann ist das technische Büro zu befragen.

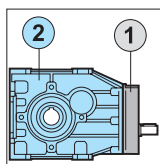
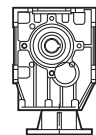
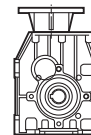
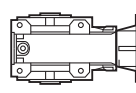
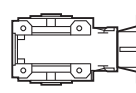
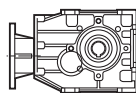
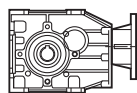

	GT	B3	B8	B6	B7	VA	VB
②	56B		0.30			0.40	0.30
①	56C			0.05			
②	56C		0.30			0.40	0.30
②	63B		0.35			0.45	0.35
①	63C			0.05			
②	63C		0.35			0.45	0.35
②	75B			0.45			
①	75C			0.08			
②	75C			0.45			

* Nella posizione di montaggio B6-B7 è previsto un tappo di sfiato con asta di livello.

* In mounting position B6-B7 the breather plug is supplied complete with the dipstick.

* Für die Version B6-B7 ist eine Entlüftungsschraube mit Ölstandsanzeige vorgesehen.

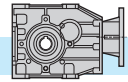

4.8 Posizione morsettiera

4.8 Terminal board position

4.8 Lage des Klemmenkastens

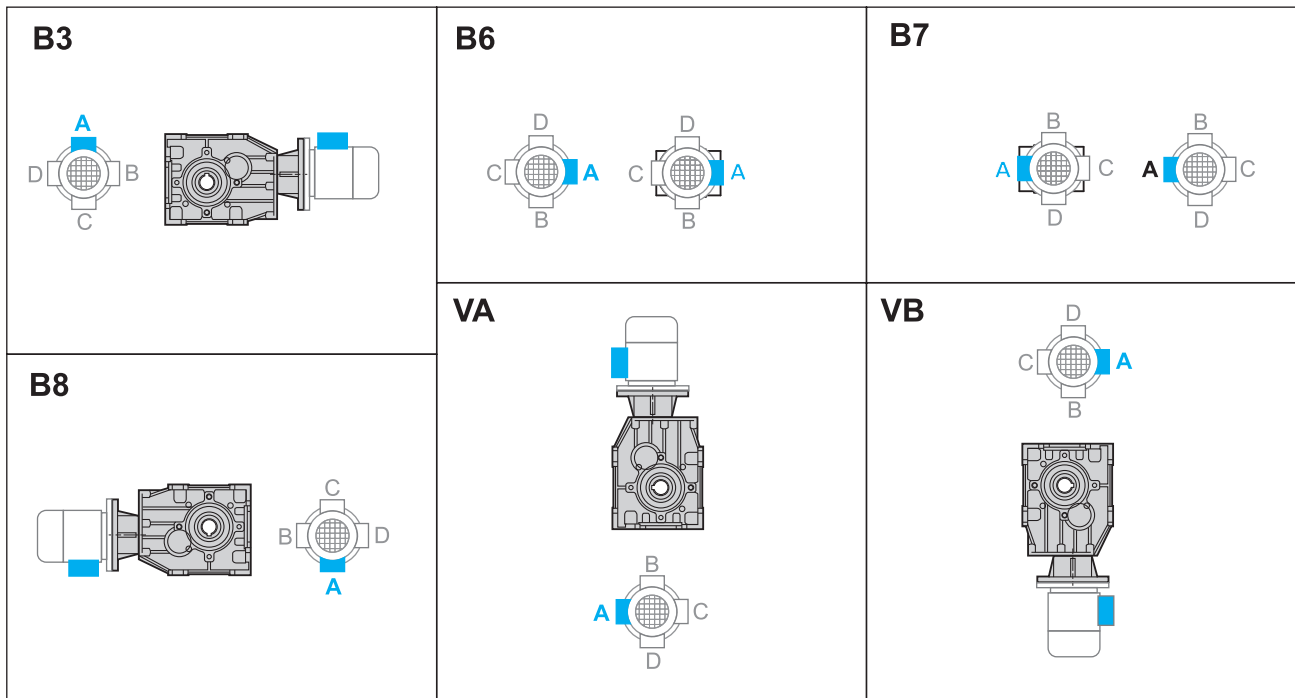

4.9 Velocità in entrata

Tutte le prestazioni dei riduttori sono calcolate in base ad una velocità in entrata di 1400 min⁻¹.

Tutti i riduttori ammettono velocità fino a 3000 min⁻¹ anche se è consigliabile, dove l'applicazione lo permette, utilizzare valori inferiori a 1400 min⁻¹.

Nella tabella sottostante riportiamo i coefficienti correttivi della potenza in entrata P alle varie velocità riferita ad Fs = 1

4.9 Input speed

All calculations of gear unit performance are based on an input speed of 1400 min⁻¹. All gear units permit speed up to 3000 min⁻¹, nevertheless it is advisable to keep below 1400 min⁻¹, depending on application.

The table below reports input power P corrective coefficients at the various speeds, with Fs = 1.

4.9 Antriebsdrehzahl

Bei der Berechnung der Getriebeleistungen wurde eine Antriebsdrehzahl von 1400 min⁻¹ berücksichtigt.

Bei allen Getrieben sind Antriebsdrehzahlen bis 3000 min⁻¹ möglich; es ist jedoch ratsam, die Drehzahlen unter 1400 min⁻¹ zu halten, wenn die Anwendung es ermöglicht.

In der folgenden Tabelle finden Sie die Korrekturkoeffizienten für die Antriebsleistung P bei den verschiedenen Drehzahlen, bezogen auf Fs = 1.

Tab. 1

n ₁ (rpm)	3000	2800	2200	1800	1400	900	700	500
P _c (kW)	P x 1.9	P x 1.8	P x 1.48	P x 1.24	P x 1	P x 0.7	P x 0.56	P x 0.42

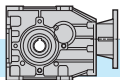

4.10 Potenza termica

I valori delle potenze termiche, P_{10} (kW), sono riportati nella tabella seguente, in funzione di grandezza, rapporto e velocità entrata del riduttore.

I valori sono calcolati considerando l'utilizzo di olio sintetico ISO 320. Vedere paragrafo 1.4 per la scelta dei fattori correttivi.

4.10 Thermal power

The following table shows the values of thermal power P_{10} (kW) for each gearbox size on the basis of ratio and input speed. The values have been calculated considering the utilization of synthetic oil ISO 320. See chapter 1.4 for the corrective coefficients.

4.10 Thermische Leistung

Die folgende Tabelle enthält die Werte P_{10} der thermischen Leistung (kW) je nach Getriebegröße und abhängig von Untersetzung und von Drehzahlen am Getriebeantrieb. Die angegebenen Werte beziehen sich auf Schmierung mit synthetischen Öl ISO 320.

Im Abschnitt 1.4 finden Sie die Korrekturkoeffizienten.

Potenza Termica / Thermal power / Thermische Leistung P_{10} [kW]						
	GTF56B		GTF63B		GTF75B	
i_n	1400	2800	1400	2800	1400	2800
8						
10						
12.5						
16						
20	4	3.4	5.5	4.7	5.6	4.8
25						
31.5						
40						
50						
63	-	-	-	-	-	-
80						

Potenza Termica / Thermal power / Thermische Leistung P_{10} [kW]						
	GTF56C		GTF63C		GTF75C	
i_n	1400	2800	1400	2800	1400	2800
40					-	-
50						
63						
80						
100	3.3	2.8	4.2	3.6	4.3	3.7
125						
160						
200						
250						
315						
400	-	-	-	-	-	-
500						
630						

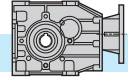

4.11 Dati tecnici

4.11 Technical data

4.11 Technische Daten

GT	n ₁ = 1400			MOTORI / MOTORS / ENGINE GHA CLASSIC			
	in	ir	n ₂ rpm	T ₂ Nm	P1 kW	FS'	IEC
56B	8	8.06	174	94	1.8	1.2	56
	10	10.17	138	120	1.8	1.0	63
	12.5	12.31	114	120	1.5	1.1	(B5)
	16	15.00	93	107	1.1	1.3	71
	20	20.33	69	140	1.1	1.0	80
	25	24.62	57	140	0.9	1.0	90
	31.5	30.00	47	107	0.55	1.3	(B5)
	40	39.38	36	140	0.55	1.0	(B14)
	50	48.00	29	115	0.37	1.2	TF
56C	40	40.28	35	140	0.55	1.0	56
	50	50.83	28	119	0.37	1.2	63
	63	61.54	23	140	0.37	1.0	(B5)
	80	75.00	19	119	0.25	1.2	71
	100	101.67	14	145	0.22	1.0	80
	125	123.08	11	141	0.18	1.0	90
	160	150.00	9	124	0.13	1.2	(B5)
	200	196.92	7	136	0.11	1.1	(B14)
	250	240.00	6	135	0.09	1.0	TF
63B	8	7.94	176	93	1.8	1.7	56
	10	10.18	138	119	1.8	1.4	63
	12.5	12.50	112	146	1.8	1.3	(B5)
	16	15.88	88	185	1.8	1.0	71
	20	20.36	69	200	1.5	1.0	80
	25	25.00	56	180	1.1	1.1	90
	31.5	31.00	45	181	0.9	1.1	(B5)
	40	40.00	35	194	0.75	1.0	(B14)
	50	49.60	28	177	0.55	1.0	TF
	63	60.80	23	146	0.37	1.0	TF
63C	40	39.71	35	194	0.75	1.0	56
	50	50.89	28	178	0.55	1.2	63
	63	62.50	22	210	0.55	1.0	(B5)
	80	79.41	18	186	0.37	1.1	71
	100	101.79	14	161	0.25	1.3	80
	125	125.00	11	198	0.25	1.0	90
	160	155.00	9	210	0.22	1.0	(B5)
	200	200.00	7	165	0.13	1.3	(B14)
	250	248.00	6	200	0.13	1.0	TF
	315	304.00	5	180	0.09	1.0	TF
75B	8	7.87	178	204	4.0	1.2	71
	10	9.82	143	254	4.0	1.1	80
	12.5	12.67	110	330	4.0	1.0	90
	16	15.43	91	299	3.0	1.1	100
	20	19.38	72	277	2.2	1.3	112
	25	25.00	56	356	2.2	1.0	(B5)
	31.5	30.45	46	355	1.8	1.1	(B14)
	40	40.00	35	285	1.1	1.3	TF
	50	48.73	29	344	1.1	1.1	TF
75C	50	49.08	29	330	1.1	1.0	63
	63	63.33	22	303	0.75	1.1	(B5)
	80	77.15	18	271	0.55	1.3	71
	100	96.88	14	350	0.55	1.0	80
	125	125.00	11	299	0.37	1.2	90
	160	152.27	9	247	0.25	1.4	(B5)
	200	200.00	7	317	0.25	1.2	(B14)
	250	243.64	6	370	0.25	1.0	TF

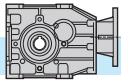

4.12 **Momenti d'inerzia** [Kg·cm²]
(riferiti all'albero veloce in entrata)

4.12 **Moments of inertia** [Kg·cm²]
(referred to input shaft)

4.12 **Trägheitsmoment** [Kg·cm²]
(bez. Antriebswelle)

GTF..B

	i_n	GTF				
		IEC B5				
		56	63	71	80	90
56B	8		0.32	0.40	0.60	0.77
	10	0.29	0.29	0.37	0.56	0.74
	12.5	0.27	0.27	0.35	0.54	0.72
	16	0.25	0.26	0.33	0.53	0.71
	20	0.15	0.15	0.22	0.42	0.60
	25	0.14	0.15	0.22	0.42	0.59
	31.5	0.14	0.14	0.21	0.41	0.59
	40	0.11	0.12	0.19	0.39	0.56
	50	0.11	0.11	0.19	0.39	0.56

	i_n	GTF				
		IEC B5				
		56	63	71	80	90
63B	8	0.47	0.47	0.55	0.74	0.92
	10	0.41	0.42	0.49	0.69	0.87
	12.5	0.38	0.38	0.45	0.65	0.83
	16	0.23	0.24	0.31	0.51	0.68
	20	0.22	0.22	0.29	0.49	0.67
	25	0.21	0.21	0.29	0.48	0.66
	31.5	0.20	0.21	0.28	0.48	0.65
	40	0.15	0.15	0.22	0.42	0.60
	50	0.14	0.15	0.22	0.42	0.60
	63	0.14	0.15	0.22	0.42	0.59

	i_n	GTF			
		IEC B5			
		71	80	90	100-112
75B	8	1.70	2.10	2.01	3.05
	10	1.55	1.96	1.87	2.91
	12.5	1.39	1.80	1.71	2.75
	16	1.34	1.74	1.65	2.69
	20	0.71	1.11	1.02	2.06
	25	0.67	1.07	0.98	2.02
	31.5	0.65	1.06	0.97	2.01
	40	0.51	0.92	0.82	1.86
	50	0.50	0.91	0.82	1.86

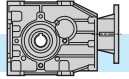



4.12 **Momenti d'inerzia** [Kg·cm²]
(riferiti all'albero veloce in entrata)

4.12 **Moments of inertia** [Kg·cm²]
(referred to input shaft)

4.12 **Trägheitsmoment** [Kg·cm²]
(bez. Antriebswelle)

GTF..C

56C	i_n	 GTF				
		IEC B5				
		56	63	71	80	90
40		0.136	0.139	0.212	0.410	0.588
50		0.134	0.138	0.211	0.409	0.587
63		0.134	0.137	0.210	0.408	0.586
80		0.133	0.137	0.210	0.408	0.585
100		0.129	0.132	0.205	0.403	0.581
125		0.129	0.132	0.205	0.403	0.581
160		0.128	0.132	0.205	0.403	0.581
200		0.127	0.131	0.204	0.402	0.580
250		0.127	0.131	0.204	0.402	0.580

63C	i_n	 GTF				
		IEC B5				
		56	63	71	80	90
40		0.142	0.145	0.218	0.416	0.594
50		0.139	0.143	0.216	0.414	0.592
63		0.138	0.142	0.215	0.413	0.590
80		0.132	0.136	0.209	0.407	0.585
100		0.132	0.135	0.208	0.406	0.584
125		0.131	0.135	0.208	0.406	0.584
160		0.131	0.135	0.208	0.406	0.583
200		0.129	0.132	0.205	0.403	0.581
250		0.129	0.132	0.205	0.403	0.581
315		0.129	0.132	0.205	0.403	0.581

75C	i_n	 GTF			
		IEC B5			
		63	71	80	90
50		0.179	0.252	0.450	0.628
63		0.173	0.246	0.444	0.622
80		0.171	0.244	0.442	0.619
100		0.145	0.219	0.417	0.594
125		0.144	0.217	0.415	0.593
160		0.143	0.216	0.414	0.592
200		0.138	0.211	0.409	0.586
250		0.137	0.210	0.408	0.586

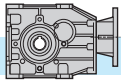

4.13 Dimensioni

4.13 Dimensions

4.13 Abmessungen

GTF56B...

2 Riduzioni/Stages/Stufen

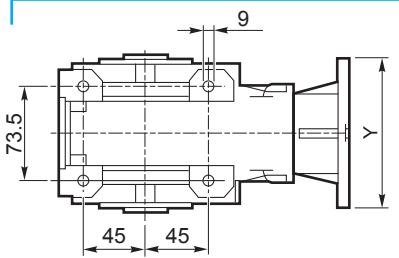

GTF56C...

3 Riduzioni/Stages/Stufen

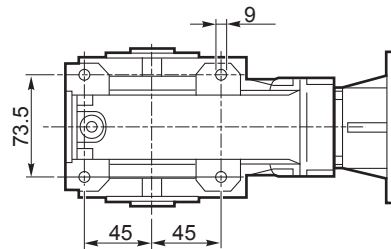
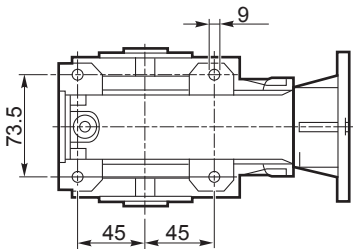
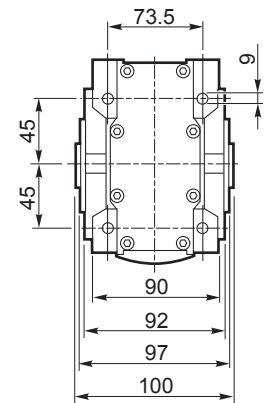
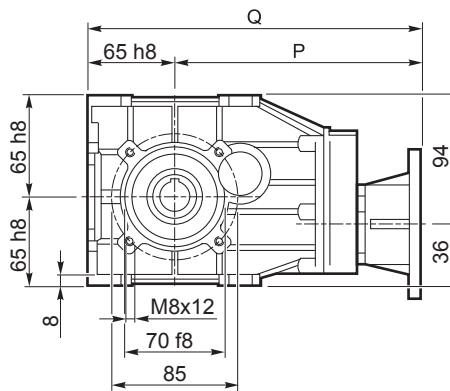
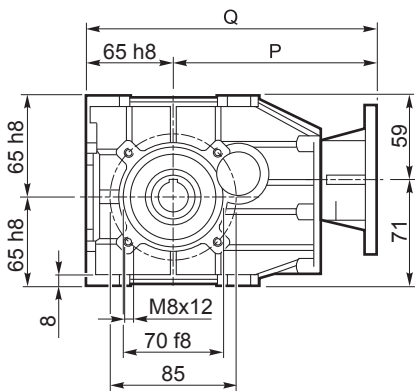
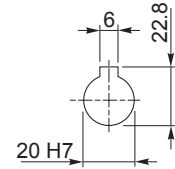
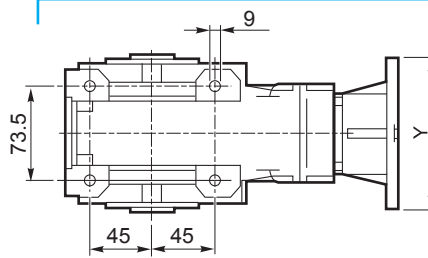

IEC	
	56 B5
	63 B5
	71 B5
	80 B5/B14
	90 B5/B14

B5	GTF...									
	56B					56C				
IEC..	56	63	71	80	90	56	63	71	80	90
Y	120	140	160	200	200	120	140	160	200	200
P	153	156	163	183	183	187	190	197	217	217
Q	218	221	228	248	248	252	255	262	282	282
kg	4.5	4.5	4.5	4.5	4.5	5.0	5.0	5.0	5.0	5.0

B14	GTF...									
	56B					56C				
IEC..	56	63	71	80	90	56	63	71	80	90
Y	—	—	105	120	140	—	—	105	120	140
P	—	—	163	183	183	—	—	197	217	217
Q	—	—	228	248	248	—	—	262	282	282
kg	—	—	4.5	4.5	4.5	—	—	5.0	5.0	5.0

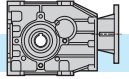

4.13 Dimensioni

4.13 Dimensions

4.13 Abmessungen

GTF63B...

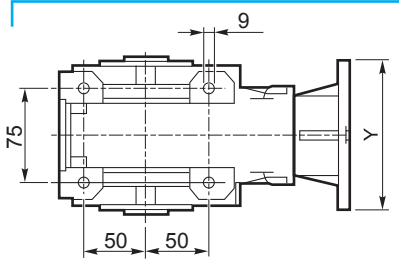

2 Riduzioni/Stages/Stufen

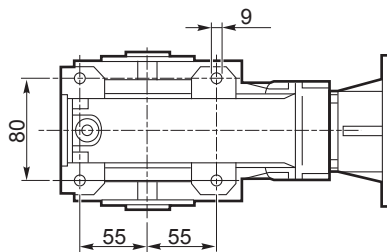
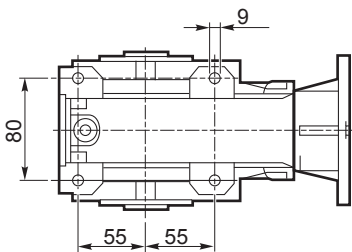
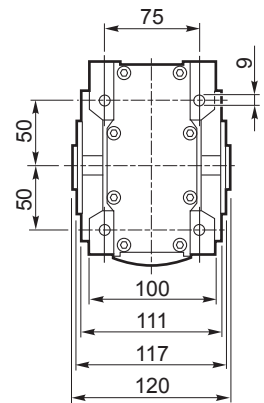
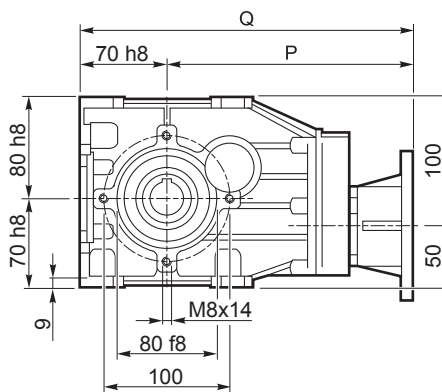
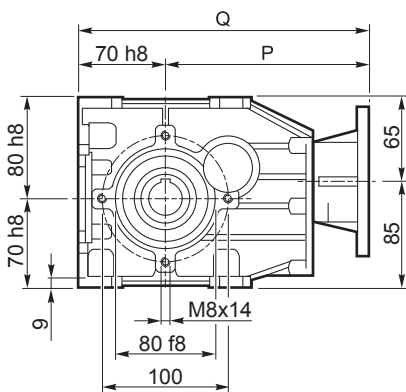
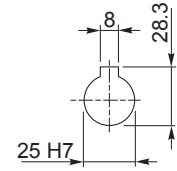
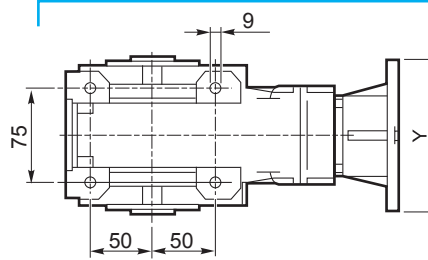

GTF63C...

3 Riduzioni/Stages/Stufen



IEC	
	
	56 B5
	63 B5
71 B14	71 B5
	80 B5/B14
	90 B5/B14

B5	GTF...									
	63B					63C				
IEC..	56	63	71	80	90	56	63	71	80	90
Y	120	140	160	200	200	120	140	160	200	200
P	160	163	170	190	190	194	197	204	224	224
Q	230	233	240	260	260	264	267	274	294	294
kg	6.0	6.0	6.0	6.0	6.0	6.5	6.5	6.5	6.5	6.5

B14	GTF...									
	63B					63C				
IEC..	56	63	71	80	90	56	63	71	80	90
Y	—	—	105	120	140	—	—	105	120	140
P	—	—	170	190	190	—	—	204	224	224
Q	—	—	240	260	260	—	—	274	294	294
kg	—	—	6.0	6.0	6.0	—	—	6.5	6.5	6.5

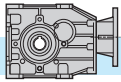

4.13 Dimensioni

4.13 Dimensions

4.13 Abmessungen

GTF75B...

2 Riduzioni/Stages/Stufen

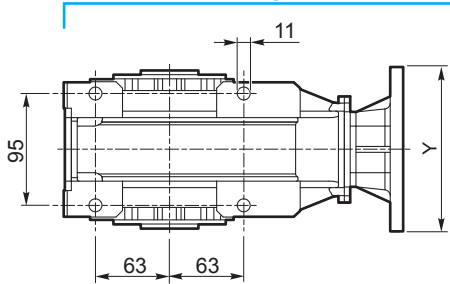

GTF75C...

3 Riduzioni/Stages/Stufen

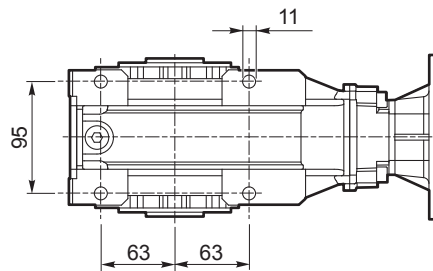
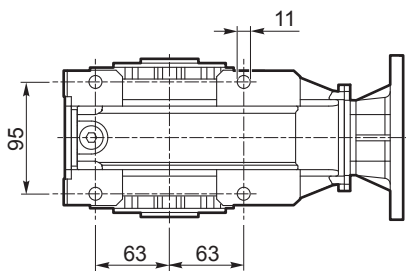
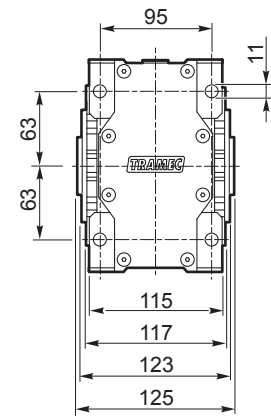
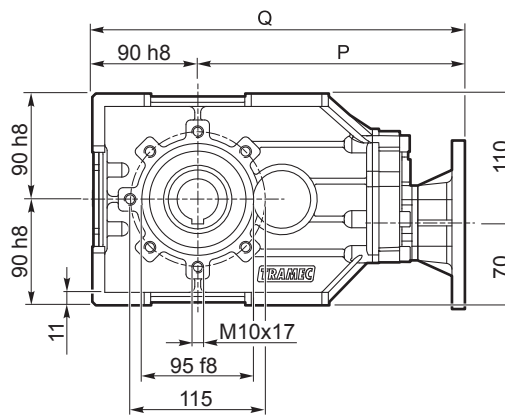
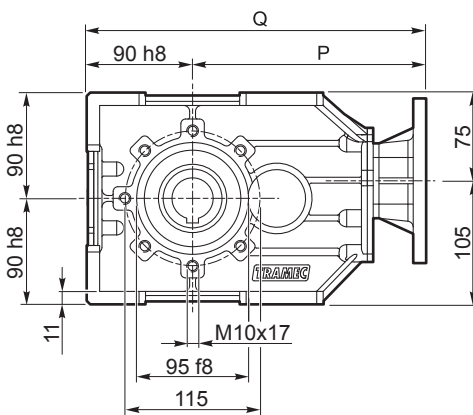
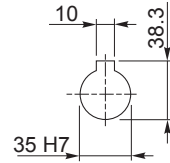
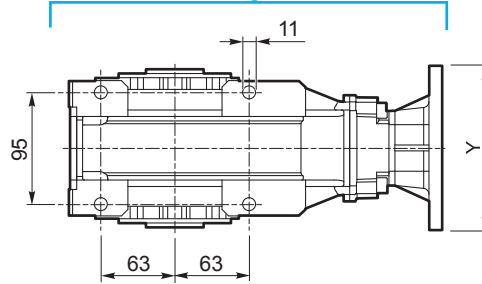

IEC	
	63 B5
71 B14	71 B5
	80 B5/B14
	90 B5/B14
	100 B5/B14

B5	GTF...									
	75B					75C				
IEC..	71	80	90	100	112	63	71	80	90	
Y	160	200	200	250	250	140	160	200	200	
P	205.5	225.5	225.5	235.5	235.5	227	234	254	254	
Q	295.5	315.5	315.5	325.5	325.5	317	324	344	344	
kg	6.5	6.5	6.5	6.5	6.5	7	7	7	7	

B14	GTF...									
	75B					75C				
IEC..	71	80	90	100	112	63	71	80	90	
Y	105	120	140	160	160	-	105	120	140	
P	205.5	225.5	225.5	235.5	235.5	-	234	254	254	
Q	295.5	315.5	315.5	325.5	325.5	-	324	344	344	
kg	6.5	6.5	6.5	6.5	6.5	7	7	7	7	

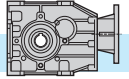

4.14 Accessori

4.14 Accessories

4.14 Zubehör

Flangia uscita

Output flange

Abtriebsflansch

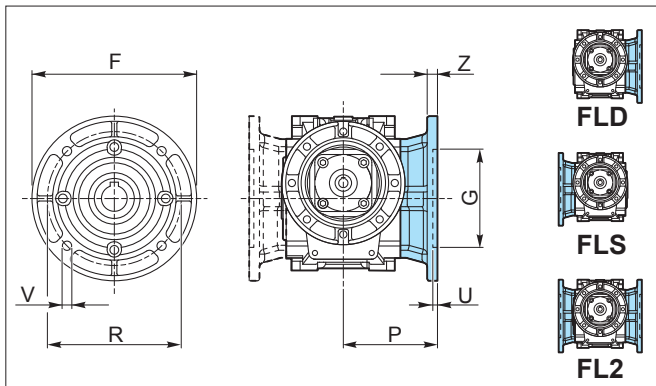

	GT		
	56B 56C	63B 63C	75B 75C
F	140	160	200
G_{F7}	95	110	130
R	115	130	165
P	82	91.5	97.5
U	5	5	5
V	9	9	12
Z	15	10	15
kg	0.5	0.5	0.9

4.15 Lista parti di ricambio

4.15 Spare parts list

4.15 Ersatzteilliste

In fase di ordine delle parti di ricambio, specificare sempre n° particolare (vedi disegno esploso), data (1), n° codice (2) e n° variante (3). (Vedi targhetta).

When ordering please specify the spare part number (see exploded view) as well as the date (1), the article number (2) and the variant number (3) (see plate)

Bei der Bestellung von Ersatzteilen sind Ersatzteilnummer (s. Explosionszeichnung), Datum (1), Artikelnummer (2) und Variantennummer (3) anzugeben. (s. Schild)

CODICE: distinta base
CODE: base list
ART.-Nr.: Basisstückliste

TIPO: descrizione
TYPE: description
TYP: Bezeichnung

RAP: rapporto di riduzione
RATIO: reduction ratio
ÜBERS: Untersetzungsverhältnis

VARIANTE:
codice alfanumerico
MODEL:
alphanumeric code
VARIANTE:
alphanumerische Nummer

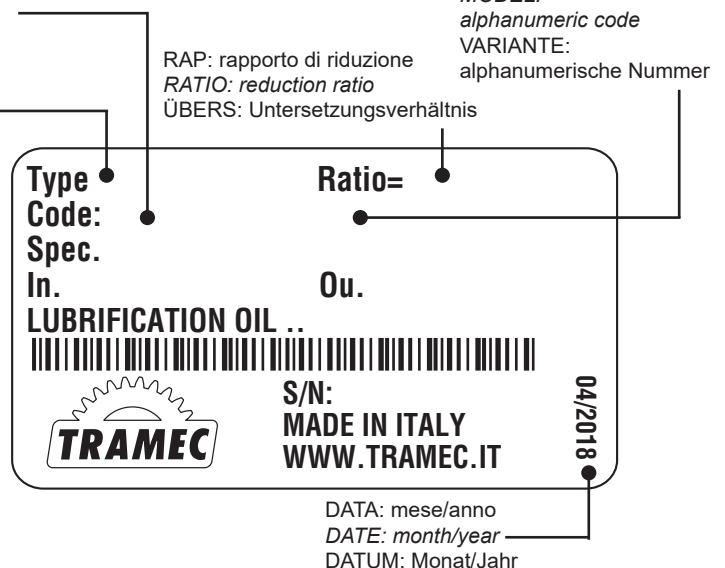

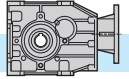

GTF 56C - GTF 63C - GTF 75C

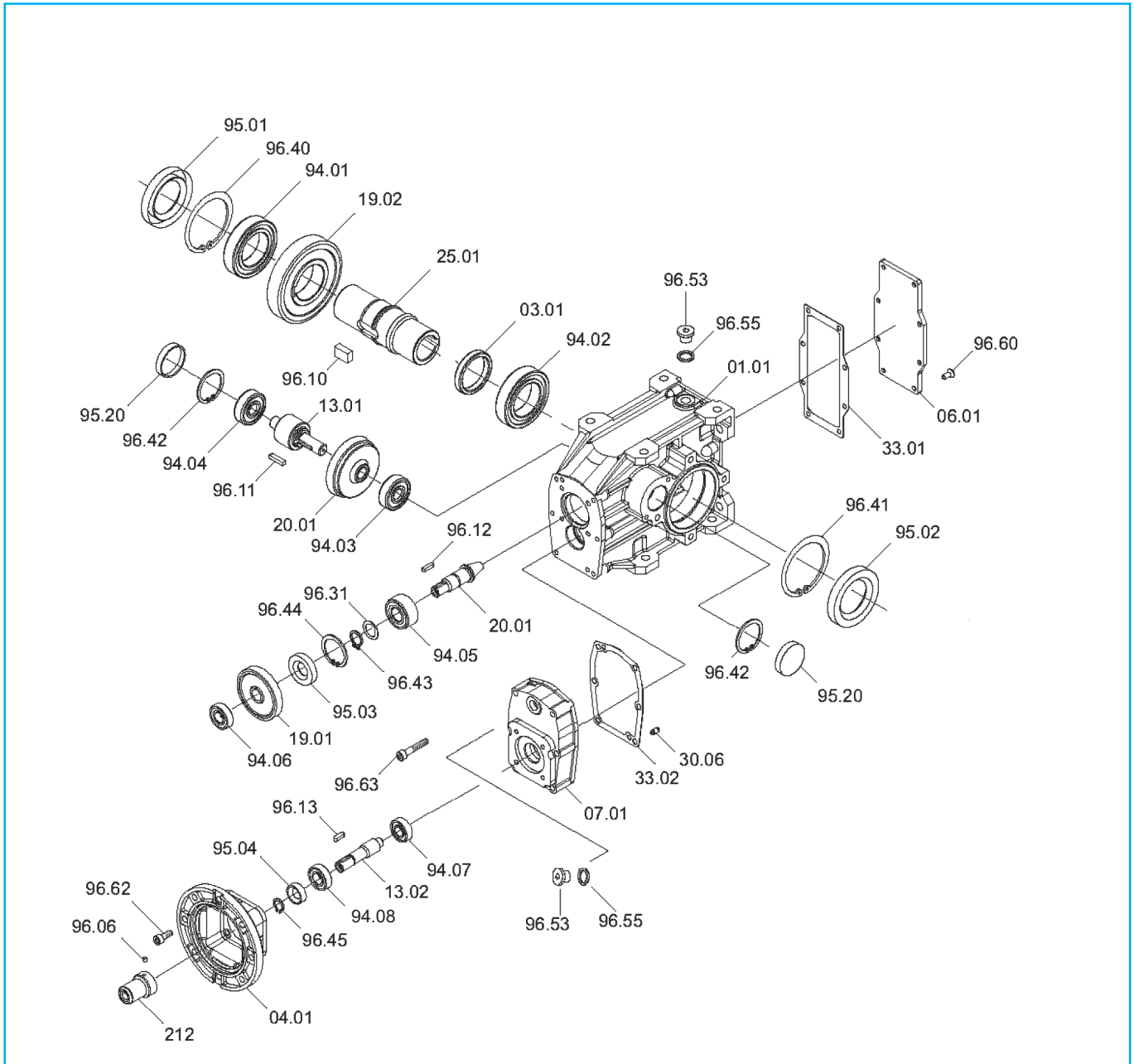

GT	Cuscinetti/ Bearings / Lager								Anelli di tenuta / Oilseals / Öldichtungen				Cappellotto / Closed oil seal / Geschlossene Öldichtung
	94.01	94.02	94.03	94.04	94.05	94.06	94.07	94.08	95.01	95.02	95.03	95.04	95.20
56C	6007 35/62/14	6007 35/62/14	6201 12/32/10	6201 12/32/10	3201 12/32/15.9	6001 12/28/8	6000 10/26/8	6001 12/28/8	35/62/7	35/62/7	12/32/7	12/22/7	ø 32x7
63C	6008 40/68/15	6008 40/68/15	6301 12/37/12	6301 12/37/12	3202 15/35/15.9	6001 12/28/8	6000 10/26/8	6001 12/28/8	40/68/10	40/68/10	15/35/7	12/22/7	ø 37x7
75C	6010 50/80/16	6010 50/80/16	6203 17/40/12	6203 17/40/12	3202 15/35/15.9	6002 16/32/9	6000 10/26/8	6001 12/28/8	50/80/8	50/80/8	15/35/7	12/22/7	ø 47x7

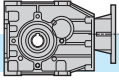

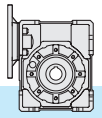

5.0	RIDUTTORI A VITE SENZA FINE GX	GX WORM GEARBOXES	SCHNECKENGETRIEBE GX
5.1	Caratteristiche	<i>Characteristics</i>	Merkmale 72
5.2	Designazione	<i>Designation</i>	Bezeichnung 73
5.3	Rendimento	<i>Efficiency</i>	Wirkungsgrad 74
5.4	Irreversibilità	<i>Irreversibility</i>	Selbsthemmung 74
5.5	Gioco angolare	<i>Backlash</i>	Winkelspiel 75
5.6	Carichi radiali	<i>Radial load</i>	Radialbelastungen 76
5.7	Senso di rotazione	<i>Direction of rotation</i>	Drehrichtung 76
5.8	Lubrificazione e posizioni di montaggio	<i>Lubrication and mounting position</i>	Schmierung und Einbaulage 77
5.9	Posizione morsettiera	<i>Terminal board position</i>	Lage des Klemmbrett 77
5.10	Dati tecnici	<i>Technical data</i>	Technische Daten 78
5.11	Momenti d'inerzia	<i>Moment of inertia</i>	Trägheitsmoment 84
5.12	Dimensioni	<i>Dimensions</i>	Abmessungen 85
5.13	Entrata supplementare	<i>Additional input</i>	Zusatzantrieb 88
5.14	Lista parti di ricambio	<i>Spare parts list</i>	Ersatzteilliste 88

GHA - MODULAR

La serie MODULAR costituisce la serie basic all'interno della gamma di riduttori GHA.

Le speciali caratteristiche NANOTECHNOLOGICHE del rivestimento e il design basic della carcassa rendono la serie MODULAR particolarmente idonea per applicazioni in ambienti ALIMENTARE (SECCO) e FARMACEUTICO.

Il riduttore non è adatto al contatto con l'alimento.

GHA - MODULAR

The MODULAR series is the basic series within the range of GHA reducers.

The special NANOTECHNOLOGICAL characteristics of the coating and the basic design of the casing make the MODULAR Series particularly suitable for applications in FOOD (dry environment) and PHARMACEUTICAL sectors.

The reducer is not suitable for contact with food.

GHA - MODULAR

Die Serie MODULAR ist die Basisbaureihe innerhalb der Produktpalette der GHA-behandelten Getriebe.

Die speziellen NANOTECHNOLOGISCHEN Eigenschaften der Beschichtung und das grundlegende Design des Gehäuses prädestinieren die MODULAR-Serie für Anwendungen in der Lebensmittel- (trockene Umgebung) und Pharmaindustrie.

Das Getriebe ist nicht für den Kontakt mit Lebensmitteln geeignet.

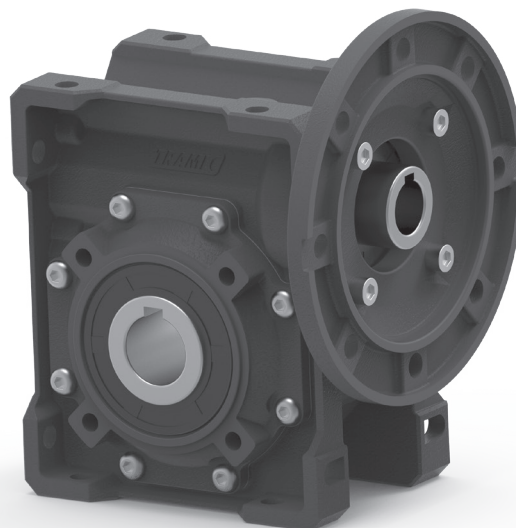

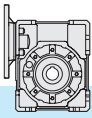

5.1 Caratteristiche

- I riduttori a vite senza fine della serie GX sono disponibili nella versione con predisposizione per attacco motore GXC.
- La serie compatta GXC presenta il vantaggio di un ingombro più ridotto.
- La vite senza fine è in acciaio legato cementato-temprato ed è rettificata.
- La corona ha il mozzo in acciaio INOX AISI 316 e l'anello dentato in bronzo GCuSn12.
- Le carcasce e flange in alluminio sono sabbiato e trattate con tecnologia G.H.A. ®
- Viene fornito l'albero uscita cavo di serie ed esiste un'ampia disponibilità di accessori: seconda entrata, kit protezione albero cavo.

5.1 Characteristics

- *GX series worm gearboxes are available in the following versions: GXC suitable for motor mounting assembling.*
- *the GX compact version, which actually offers reduced space requirement.*
- *The worm shaft is made of hardened-bonded steel and ground.*
- *The wheel has an AISI 316 stainless steel hub with a toothed ring made in bronze GcuSn12.*
- *Aluminum housings and flanges are sandblasted and treated in accordance with G.H.A. ® technology.*
- *The hollow output shaft is supplied as standard. A broad range of accessories is available: second input, hollow shaft protection kit.*

5.1 Merkmale

- Die Schneckengetriebe der Serie GX sind in die Version GXC mit Motoranschluß lieferbar.
- Die kompakte GXC-Serie hat den Vorteil einer geringeren Stellfläche
- Die Schneckenwelle ist aus einsatzgehärtetem, abgeschrecktem und daraufhin geschliffenem Legierungsstahl
- Das Schneckenrad besteht aus einer Nabe aus Edelstahl AISI 316 und einer Bronze- Verzahnung GCuSn12.
- Die Aluminiumgehäuse und Flansche sind sandgestrahlt und mit G.H.A. ® - Technik behandelt.
- Die Hohlwelle gehört zur serienmäßigen Ausstattung. Eine breite Auswahl an Zubehör ist erhältlich: Zweiteingang, Schutzvorrichtung für Hohlwelle.

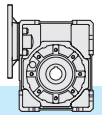

5.2 Designazione

5.2 Designation

5.2 Bezeichnung

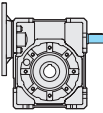
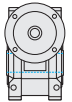
Riduttore Gearbox Getriebe	Tipo entrata Input type Antriebsart	Grandezza Size Größe	Rapporto rid. Ratio Untersetzung	Predispos. att. mot. Motor coupling Motoranschluss	Posizione di mont. Mounting position Einbaulage	Seconda entrata Additional input Zusatzantrieb	Albero uscita Output shaft Abtriebswelle
GX	C	50	10/1	P.A.M	B3	SeA	H25
Riduttore a vite senza fine Wormgearbox Schneckengetriebe	 C	30 40 50 63 75 89	5 7.5 10 15 20 25 30 40 50 65 80 100	56 63 71 80 90 100 112	B3, B6 B7, B8 V5, V6	 SeA	 H..

Tipo entrata

Input type

Antriebstyp

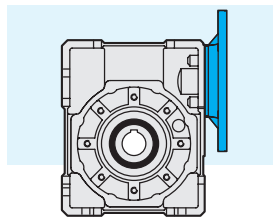

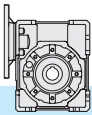

5.3 Rendimento

Rd - È il rendimento dinamico, definito come rapporto tra la potenza in uscita P_2 e quella in entrata P_1 . Dipende principalmente dalla velocità di strisciamento, dal tipo di lubrificante e dall'angolo d'elica. I valori indicati nelle tabelle sono validi se si applica la corrispondente coppia in uscita. In fase di rodaggio, circa le prime 300 ore di funzionamento sotto carico, il valore deve essere considerato inferiore del 30% rispetto a quello indicato in tabella.

Rs - È il rendimento statico che si ha al momento dell'avviamento del riduttore e varia in base al rapporto di riduzione. Risulta importante, per una corretta valutazione del riduttore da impiegare, nelle applicazioni in cui non si raggiungono mai le condizioni di regime come nei funzionamenti intermittenti. Analogamente al caso dinamico, anche il rendimento statico durante il rodaggio risulta inferiore del 30% rispetto al valore indicato in tabella.

5.3 Efficiency

Rd - dynamic efficiency, defined as the ratio between P_2 output power and P_1 input power. It mainly depends on the slipping speed, the type of lubricant and the lead angle. The values reported in the table are valid when the corresponding output torque is applied. During the first 300 operating hours under load, the value to be considered is 30% lower than that reported in the table.

Rs - static efficiency at gearbox start-up; it changes depending on the reduction ratio. Rs value is important for selecting the right gearbox for applications where a steady state is never achieved, as for intermittent duty applications. Same as dynamic efficiency, static efficiency too during the running-in period will be 30% lower than the value reported in the table.

5.3 Wirkungsgrad

Rd - dynamischer Wirkungsgrad, ist das Verhältnis zwischen P_2 Abtriebsleistung und P_1 Antriebsleistung. Rd Wert wird durch Gleitgeschwindigkeit, Art des Schmiermittels und Steigungswinkel beeinflusst. Die Tabellen zeigen die Werte die gültig sind wenn das entsprechende Abtriebsdrehmoment gegeben ist. Während der Einlaufzeit in den ersten 300 Betriebsstunden unter Belastung, ist dieser Wert 30% niedriger als der in der Leistungstabelle angegebenen Wert.

Rs - statischer Wirkungsgrad beim Getriebebestart und in Abhängigkeit zur Unterersetzung. Der Wert Rs ist wichtig für die Auswahl des richtigen Getriebes für Anwendungen wo ein stetiger Betrieb nicht auftritt, wie bei Anwendungen mit Aussetzbetrieb. Der statischer Wirkungsgrad auch während der Einlaufzeit wird 30% niedriger als der in der Tabelle angegebenen Wert.

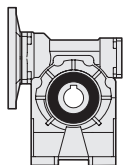

GX	Rs											
	5	7.5	10	15	20	25	30	40	50	65	80	100
30	0.70	0.67	0.62	0.55	0.47	0.43	0.39	0.30	0.27	0.25	0.22	0.21
40	0.69	0.67	0.63	0.55	0.52	0.45	0.40	0.35	0.29	0.26	0.25	0.23
50	0.69	0.68	0.65	0.58	0.53	0.47	0.41	0.37	0.32	0.28	0.25	0.23
63	0.70	0.68	0.65	0.57	0.55	0.50	0.47	0.38	0.33	0.29	0.28	0.23
75	/	0.68	0.65	0.58	0.55	0.51	0.43	0.39	0.35	0.31	0.28	0.24
89	/	0.68	0.65	0.58	0.55	0.52	0.45	0.39	0.36	0.32	0.29	0.25

5.4 Irreversibilità

Nelle applicazioni dove è necessario evitare la trasmissione del moto retrogrado o sostenere il carico, in assenza di alimentazione elettrica, è consigliabile adottare freni esterni.

Nei riduttori a vite senza fine emerge questa caratteristica naturale, denominata grado di irreversibilità, che cresce con l'aumentare del rapporto di riduzione in quanto strettamente legata al relativo rendimento.

Per ottenere alti gradi di irreversibilità occorre quindi adottare i rapporti di riduzione più elevati, senza dimenticare che, il rendimento, tende a crescere durante le prime 500 ore di funzionamento per poi stabilizzarsi sui valori riportati a catalogo.

5.4 Irreversibility

The use of external brakes is advised in case of applications where backwards motion must be hindered and the load must be held should the feed be cut off.

Some worm gearboxes feature natural irreversibility. The higher the ratio, the higher is the irreversibility, since it is strictly dependent on the relative efficiency.

In order to achieve high irreversibility it is therefore necessary to select higher efficiency reduction ratios not to forget that the efficiency is growing during the first 500 hours life until it stabilizes to the values mentioned in the catalogue.

5.4 Selbsthemmung

Aussenbremsen sind bei Anwendungen zu benutzen, bei denen Rückbewegung vermeiden werden muss oder die Last auch im Falle von Fehlen an Speisung gehalten werden muss.

Einige Schneckengetriebe sind selbsthemmend. Je höher die Unterersetzung ist, desto höher ist die Selbsthemmung, da diese stark vom jeweiligen Wirkungsgrad abhängig ist. Um eine höhere Selbsthemmung zu erreichen, wählen Sie bitte höhere Untersetzungsverhältnisse.

Bitte beachten Sie, dass der Wirkungsgrad der Getriebe in den ersten 500 Betriebsstunden ansteigt und sich erst anschließend auf die im Katalog angegebenen Werte stabilisiert.

Irreversibilità statica

Condizione di impedimento alla rotazione comandata dall'albero lento senza escludere possibili ritorni lenti nel caso in cui il carico sia sottoposto a vibrazioni.

Rs < 0.45 si ha irreversibilità
Rs = 0.45 ÷ 0.55 irreversibilità incerta
Rs > 0.55 si ha reversibilità

Static irreversibility

Static irreversibility occurs when the rotation controlled by the output shaft is hindered; possible slow returns cannot be excluded should the load be subject to vibrations.

Rs < 0.45 provides irreversibility
Rs = 0.45 ÷ 0.55 irreversibility is uncertain
Rs > 0.55 reversibility is possible

Statische Selbsthemmung

Statische Selbsthemmung liegt vor, wenn die von Abtriebswelle gesteuerten Drehung gehindert wird. Langsamer Rücklauf ist möglich, falls die Last Schwingungen ausgesetzt wird.

Rs < 0.45 es liegt Selbsthemmung vor
Rs = 0.45 ÷ 0.55 ungewisse Selbsthemmung
Rs > 0.55 es liegt Reversibilität vor

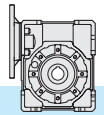

Irreversibilità dinamica

Condizione di arresto e quindi di sostegno del carico nel momento in cui cessa l'azione di comando. La condizione è più difficile da ottenere in quanto viene influenzata dal rendimento dinamico, dalla velocità di rotazione, da eventuali vibrazioni che il carico può generare e dalla direzione del movimento rispetto al carico.

Quest'ultima condizione è molto evidente nei sollevamenti: un carico in salita, cessando l'azione di comando, deve arrestarsi e quindi assumere velocità zero (rendimento statico) prima di invertire il moto e cadere per gravità.

Un carico in discesa tende invece a proseguire nel suo moto ostacolato, nella caduta, dal solo rendimento dinamico.

Rd < 0.45 si ha irreversibilità
Rd = 0.45 ÷ 0.55 irreversibilità incerta
Rd > 0.55 si ha reversibilità

Dynamic irreversibility

Dynamic irreversibility is characterized by stillstand and hold of the load when the drive stops. It is more difficult to achieve this condition because it is influenced by dynamic efficiency, speed of rotation and possible vibrations generated by the motion direction with regard to the load.

This last condition is much more evident during the lifting : if the drive stops during the lifting of the load this has to come to a speed equals to zero (static irreversibility) before the reversal of motion rotation and its drop for gravity.

On the contrary the load during its descent gets its motion obstructed by its dynamic efficiency.

Rd < 0.45 provides irreversibility
Rd = 0.45 ÷ 0.55 irreversibility is uncertain
Rd > 0.55 reversibility is possible

Dynamische Selbsthemmung

Stillstand und Stütze der Last beim Aussetzen der Steuerung. Diese Bedingung ist schwieriger zu erreichen, da sie vom dynamischen Wirkungsgrad, der Drehzahl und von der Last verursachten möglichen Vibrationen abhängig ist

Dieser letzte Fall kommt bei Hubanwendungen stark zu tragen. Wenn der Antrieb während dem Hub stoppt, muss die Last eine Geschwindigkeit von annähernd null erreichen (statische Irreversibilität), bevor die Rotation sich umkehrt und die Last durch die Gravitation nach unten fährt. Dem entgegengesetzt bekommt die Last durch die Abwärtsbewegung Ihre dynamische Effizienz.

Rd < 0.45 es liegt Selbsthemmung vor
Rd = 0.45 ÷ 0.55 ungewisse Selbsthemmung
Rd > 0.55 es liegt Reversibilität vor

5.5 Gioco angolare

Gioco angolare standard

Misurato bloccando l'albero entrata, e ruotando l'albero uscita nelle due direzioni applicando la coppia strettamente necessaria a creare il contatto tra i denti degli ingranaggi, al massimo pari al 2% della coppia nominale (T_{2M}).

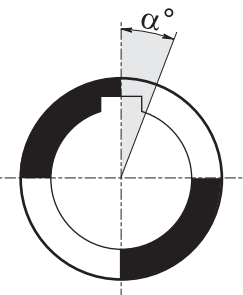

5.5 Backlash

Backlash

Angular backlash measured after having blocked the input shaft by rotating output shaft in both directions and applying the torque which is strictly necessary to create a contact between the teeth of the gears. The applied torque should be at most 2% of the max. torque (T_{2M}).

5.5 Winkelspiel

Winkelspiel

Nachdem die Antriebswelle blockiert worden ist, darf das Winkelspiel auf die Abtriebswelle bemessen werden. Dabei soll die Antriebswelle in beiden Richtungen gedreht werden und ein Drehmoment ausgeübt werden, das zur Entstehen eines Kontaktes zwischen den Zahnen genuegt. Das ausgeübte Drehmoment soll höchstens 2% des max. von Getrieben garantierten Drehmoment (T_{2M}) sein.

GX						
i_n	30	40	50	63	75	89
	max	max	max	max	max	max
5	16'	13.5'	10.5'	10'	/	/
7.5	16'	13.5'	10.5'	10'	10'	9.5'
10	16'	13.5'	10.5'	10'	10'	9'
15	16'	13.5'	10.5'	10'	10'	9'
20	14.5'	12'	9.5'	8.5'	8.5'	8.5'
25	14.5'	12'	9.5'	8.5'	8.5'	8.5'
30	14.5'	12'	8.5'	8.5'	8.5'	8.5'
40	14.5'	12'	9.5'	8.5'	8.5'	8'
50	14'	12'	9.5'	8.5'	8.5'	8'
65	14'	12'	9'	8'	8'	8'
80	13.5'	11.5'	9'	7.5'	7.5'	7.5'
100	13'	11'	9'	7.5'	7.5'	7.5'

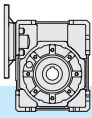

5.6 Carichi radiali

Carichi radiali Fr_2 e assiali Fa_2 sull'albero uscita [N]

Se il carico radiale sull'albero non è applicato a metà della sporgenza dell'albero, il valore del carico ammissibile deve essere valutato utilizzando la formula che si riferisce ad Fry_2 , in cui i valori di a, b e Fr_2 sono riportati nelle tabelle relative ai carichi radiali.

Nel caso di alberi bisporgenti il valore del carico applicabile a ciascuna estremità è uguale ai 2/3 del valore di tabella, purchè i carichi applicati siano uguali di intensità e direzione ed agiscano nello stesso senso. Diversamente contattare il servizio tecnico.

5.6 Radial load

Fr_2 radial loads and Fa_2 axial loads on the output shaft [N]

Should the radial load affect the shaft not at the half-way point of its projection but at a different point, the value of the admissible load has to be calculated using the Fry_2 formula: a, b and Fr_2 values are reported in the radial load tables.

With regard to double-projecting shafts, the load applicable at each end is 2/3 of the value given in the table, on condition that the applied loads feature same intensity and direction and that they act in the same direction.

Otherwise please contact the technical department.

5.6 Radialbelastungen

Fr_2 Radialbelastungen und Fa_2 Axialbelastungen auf die Abtriebswelle [N]

Falls die Radialbelastungen nicht in dem Mittelpunkt der herausragenden Welle sondern in einem anderen Punkt wirken, soll die zulässige Belastung mit der Formel bezüglich Fry_2 kalkuliert werden: a, b und Fr_2 Werte sind aus der Tabelle der Radialbelastungen zu entnehmen.

Bei doppelseitigen Abtriebswellen ist die Belastung, die an jedem Ende anwendbar ist, 2/3 des in der Tabelle angegebenen Wertes unter der Bedingung, dass die Belastungen die selbe Stärke und Richtung aufweisen und dass sie in der selben Richtung wirken. Andernfalls muß mit dem technischen Büro Rücksprache gehalten werden.

I carichi radiali indicati nelle tabelle si intendono applicati a metà della sporgenza dell'albero e sono riferiti ai riduttori operanti con fattore di servizio 1.

The radial loads indicated in the chart are considered to be applied at the half-way point of the shaft projection, and refer to gear units operating with service factor 1.

Die Radialbelastungen, die in den Tabellen angegeben werden, gelten für Ansatzpunkte in der Mitte des herausragenden Wellenteils und für Getriebe mit Betriebsfaktor 1.

		GX											
$n_1=1400$ rpm		30		40		50		63		75		89	
i_n	n_2 [rpm]	a = 66.5 b = 49		a = 83.5 b = 60.5		a = 102 b = 73.5		a = 122.5 b = 93.5		a = 134 b = 100		a = 163 b = 118	
		Fr_2	Fa_2	Fr_2	Fa_2	Fr_2	Fa_2	Fr_2	Fa_2	Fr_2	Fa_2	Fr_2	Fa_2
5	280	700	140	1400	280	1400	300	1800	360	/	/	/	/
7.5	187	750	150	1500	300	1650	330	2100	420	2500	500	2600	520
10	140	800	160	1600	320	1800	360	2300	460	2800	560	3000	600
15	93	850	170	1700	340	1950	390	2600	520	3000	600	3400	680
20	70	900	180	1800	360	2200	440	2800	560	3300	660	3800	760
25	56	950	190	1900	380	2400	480	3100	620	3700	740	4100	820
30	47	1000	200	2000	400	2600	520	3400	680	4000	800	4500	900
40	35	1050	210	2100	420	2850	570	3700	740	4400	880	4900	980
50	28	1100	220	2200	440	3100	620	4000	800	4850	970	5300	1060
60	23	1150	230	2400	480	3200	640	4200	840	5000	1000	5600	1120
63	22	1250	250	2500	500	3400	680	4450	890	5300	1060	5900	1180
80	17.5	1350	270	2700	540	3800	760	4900	980	5800	1160	6500	1300
100	14	1500	300	3000	600	4000	800	5400	1080	6500	1300	7000	1400

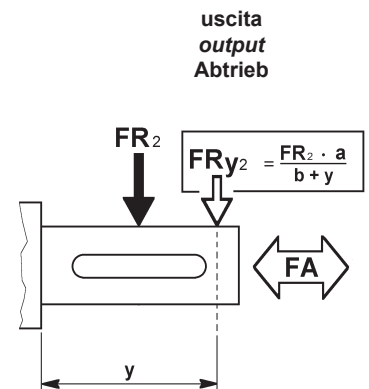

5.7 Senso di rotazione

5.7 Direction of rotation

5.7 Drehrichtung

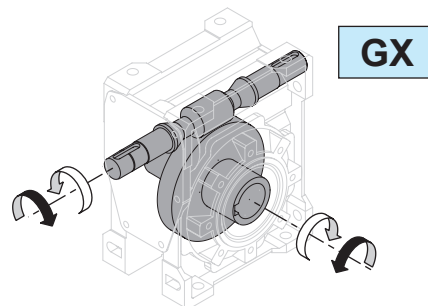

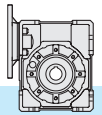

5.8 Lubrificazione

I riduttori a vite senza fine serie GX sono forniti completi di lubrificante sintetico per uso alimentare: OLIO FUCHS CASSIDA FLUID 320.

Si raccomanda di precisare sempre, in fase di ordine, la posizione di montaggio desiderata.

Posizioni di montaggio

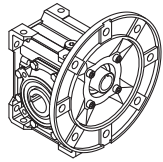

B3

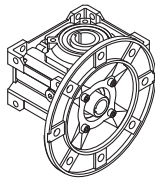

B6

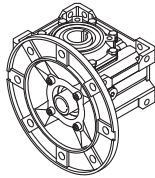

B7

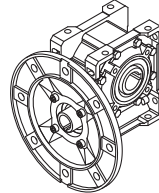

B8

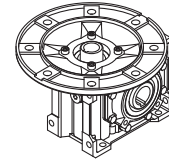

V5

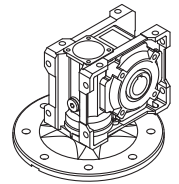

V6

5.8 Lubrication

The GX series worm gearboxes are supplied complete with synthetic lubricant for food use: FUCHS CASSIDA FLUID 320 OIL.

Mounting position always to be specified when ordering.

Mounting positions

5.8 Schmierung

Die Schneckengetriebe der Serie GX werden mit synthetischem Lebensmittelöl FUCHS CASSIDA FLUID 320 geliefert.

Bei der Bestellung bitte immer die gewünschte Einbaulage angeben.

Einbaulagen

		Q.tà olio / Oil quantity / Schmiermittelmenge [lt]			
		Posizione di montaggio / Mounting position / Einbaulage			
		B3	B6 - B7	B8	V5 - V6
GX	30	0.015	0.030	0.015	
	40	0.040	0.060	0.040	
	50	0.080	0.120	0.080	
	63	0.160	0.220	0.160	
	75	0.260	0.340	0.260	
	89	1.1	0.9	1	1.5

E' presente un solo tappo di riempimento olio.

Aluminium housings have one oil filling plug only.

Aluminiumgehäuse verfügen über 1 Einfüllschraube.

5.9 Posizione morsettiera

5.9 Terminal board position

5.9 Lage der Klemmenkaste

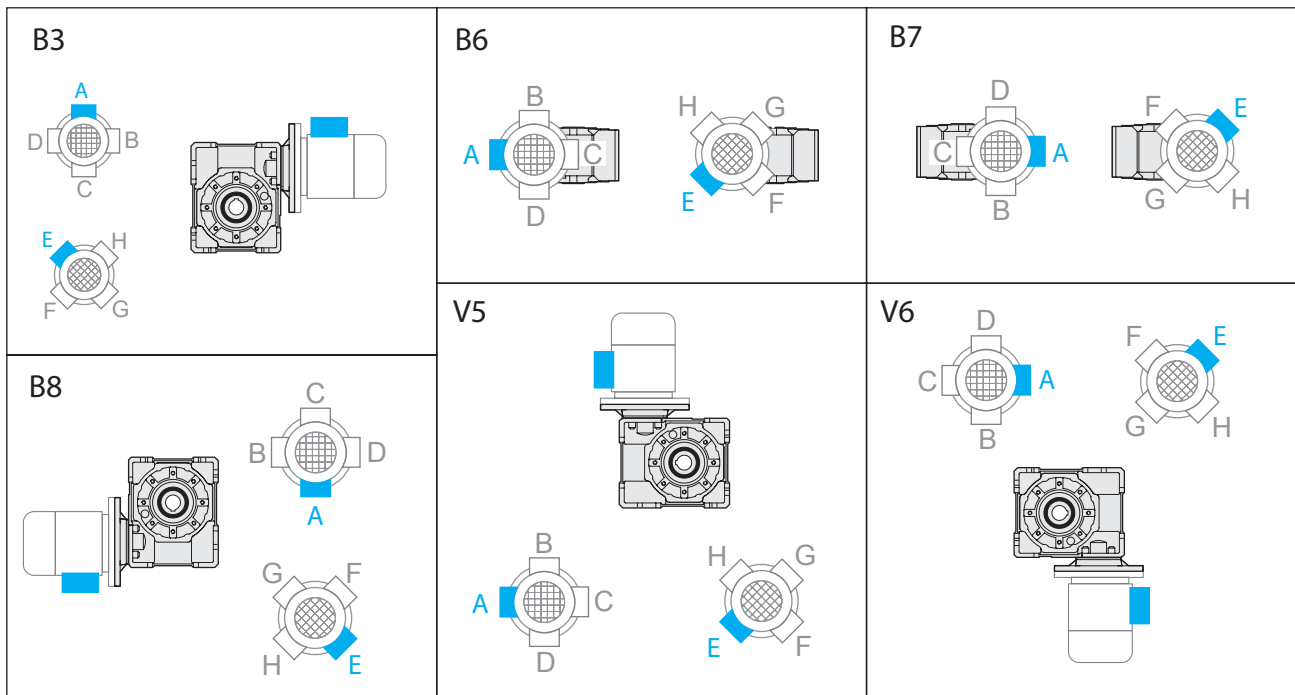

Specificare sempre in fase di ordinazione la posizione di montaggio e la forma costruttiva.
Posizione morsettiera v. pag. 89 (PM=1; PM=2)

Mounting position always to be specified when ordering.
Terminal board position see page 89 (PM=1; PM=2)

Bei der Bestellung immer die gewünschte Montageposition und Bauform angeben.
Lage der Klemmenkaste Seite 89 (PM=1; PM=2)

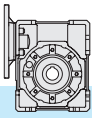

5.10 Dati tecnici

5.10 Technical data

5.10 Technische Daten

GXC 30	$n_1 = 2800$				MOTORI / MOTORS / ENGINE GHA CLASSIC				Input - IEC	
	i_n	n_2 [min ⁻¹]	Rd	P_{t0}	T_2 [Nm]	P_1 [kW]	FS'	B5/B14		
	5	560	0.89	—	5.6	0.37	2.5	63	56	
7.5	373	0.86	8		0.37	2.0				
10	280	0.84	11		0.37	1.5				
15	187	0.81	15		0.37	1.1				
20	140	0.76	13		0.25	1.2				
25	112	0.74	16		0.25	1.0				
30	93	0.71	13		0.18	1.0				
40	70	0.65	16		0.18	1.0				
50	56	0.62	14		0.13	1.1				
65	43	0.57	17		0.13	1.0				
80	35	0.54	13		0.09	1.0				
100	28	0.52	16	0.09	0.8	—	—			



1.4

GXC 30	$n_1 = 1400$				MOTORI / MOTORS / ENGINE GHA CLASSIC				Input - IEC	
	i_n	n_2 [min ⁻¹]	Rd	P_{t0}	T_2 [Nm]	P_1 [kW]	FS'	B5/B14		
	5	280	0.87	0.40	6.5	0.22	2.9	63	56	
7.5	187	0.84	0.40	9	0.22	2.2				
10	140	0.82	0.40	12	0.22	1.8				
15	93	0.77	0.30	17	0.22	1.3				
20	70	0.72	0.20	18	0.18	1.1				
25	56	0.69	0.20	21	0.18	1.0				
30	47	0.66	0.20	18	0.13	1.1				
40	35	0.59	0.20	21	0.13	1.0				
50	28	0.55	0.20	17	0.09	1.1				
65	22	0.51	0.10	20	0.09	1.0				
80	18	0.48	0.10	16	0.06	1.0				
100	14	0.45	0.10	18	0.06	0.8	—	—		



1.4

GXC 30	$n_1 = 900$				MOTORI / MOTORS / ENGINE GHA CLASSIC				Input - IEC	
	i_n	n_2 [min ⁻¹]	Rd	P_{t0}	T_2 [Nm]	P_1 [kW]	FS'	B5/B14		
	5	180	0.85	—	5.9	0.13	3.9	63	56	
7.5	120	0.82	9		0.13	2.9				
10	90	0.80	11		0.13	2.3				
15	60	0.75	15		0.13	1.6				
20	45	0.69	19		0.13	1.2				
25	36	0.66	23		0.13	1.1				
30	30	0.63	18		0.09	1.2				
40	23	0.55	21		0.09	1.1				
50	18	0.52	16		0.06	1.1				
65	14	0.48	20		0.06	1.1				
80	11	0.44	11		0.03	1.7				
100	9	0.42	13	0.03	1.1	—	—			



1.4

GXC 30	$n_1 = 500$				MOTORI / MOTORS / ENGINE GHA CLASSIC				Input - IEC	
	i_n	n_2 [min ⁻¹]	Rd	P_{t0}	T_2 [Nm]	P_1 [kW]	FS'	B5/B14		
	5	100	0.83	—	—	—	—	63	56	
7.5	67	0.80	—		—	—				
10	50	0.77	—		—	—				
15	33	0.72	—		—	—				
20	25	0.66	—		—	—				
25	20	0.62	—		—	—				
30	17	0.59	—		—	—				
40	13	0.51	—		—	—				
50	10	0.48	—		—	—				
65	8	0.43	—		—	—				
80	6	0.40	—		—	—				
100	5	0.38	—	—	—	—	—			



1.4

* **ATTENZIONE:** la coppia massima utilizzabile $[T_{2M}]$ deve essere calcolata utilizzando il fattore di servizio: $T_{2M} = T_2 \times FS'$

* **WARNING:** Maximum allowable torque $[T_{2M}]$ must be calculated using the following service factor: $T_{2M} = T_2 \times FS'$

* **ACHTUNG:** das max. anwendbare Drehmoment $[T_{2M}]$ muss mit folgendem Betriebsfaktor berechnet werden: $T_{2M} = T_2 \times FS'$

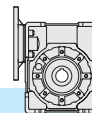

5.10 Dati tecnici

5.10 Technical data

5.10 Technische Daten

GXC 40	n₁ = 2800				MOTORI / MOTORS / ENGINE GHA CLASSIC						
	i _n	n ₂ [min ⁻¹]	Rd	P ₁₀	T ₂ [Nm]	P ₁ [kW]	FS'	Input - IEC			
								B5/B14			
Kg 2.4	5	560	0.88	—	11.3	0.75	2.2	71	63	—	
	7.5	373	0.87		17	0.75	1.8				
	10	280	0.86		22	0.75	1.4				
	15	187	0.82		32	0.75	1.0				
	20	140	0.80		30	0.55	1.0				
	25	112	0.76		24	0.37	1.1				
	30	93	0.73		28	0.37	1.3				
	40	70	0.70		24	0.25	1.4				
	50	56	0.65		28	0.25	1.1				
	65	43	0.61		24	0.18	1.2				
	80	35	0.58		21	0.13	1.3				
100	28	0.55	24	0.13	1.0	—	—	56			

GXC 40	n₁ = 1400				MOTORI / MOTORS / ENGINE GHA CLASSIC						
	i _n	n ₂ [min ⁻¹]	Rd	P ₁₀	T ₂ [Nm]	P ₁ [kW]	FS'	Input - IEC			
								B5/B14			
Kg 2.4	5	280	0.87	0.80	16.3	0.55	2.1	71	63	—	
	7.5	187	0.85	0.80	24	0.55	1.7				
	10	140	0.83	0.70	31	0.55	1.3				
	15	93	0.79	0.50	30	0.37	1.4				
	20	70	0.76	0.50	38	0.37	1.0				
	25	56	0.72	0.40	31	0.25	1.1				
	30	47	0.68	0.40	35	0.25	1.2				
	40	35	0.64	0.30	38	0.22	1.0				
	50	28	0.59	0.30	36	0.18	1.1				
	65	22	0.54	0.20	31	0.13	1.1				
	80	18	0.52	0.20	31	0.11	1.1				
100	14	0.49	0.20	30	0.09	0.9	—	—	56		

GXC 40	n₁ = 900				MOTORI / MOTORS / ENGINE GHA CLASSIC						
	i _n	n ₂ [min ⁻¹]	Rd	P ₁₀	T ₂ [Nm]	P ₁ [kW]	FS'	Input - IEC			
								B5/B14			
Kg 2.4	5	180	0.85	—	16.7	0.37	2.5	71	63	—	
	7.5	120	0.83		25	0.37	2.0				
	10	90	0.81		32	0.37	1.5				
	15	60	0.76		45	0.37	1.1				
	20	45	0.74		39	0.25	1.2				
	25	36	0.69		33	0.18	1.3				
	30	30	0.65		37	0.18	1.3				
	40	23	0.61		33	0.13	1.3				
	50	18	0.55		38	0.13	1.1				
	65	14	0.51		32	0.09	1.2				
	80	11	0.48		37	0.09	1.0				
100	9	0.45	29	0.06	1.0	—	—	56			

GXC 40	n₁ = 500				MOTORI / MOTORS / ENGINE GHA CLASSIC						
	i _n	n ₂ [min ⁻¹]	Rd	P ₁₀	T ₂ [Nm]	P ₁ [kW]	FS'	Input - IEC			
								B5/B14			
Kg 2.4	5	100	0.83	—	7.1	0.09	7.1	71	63	—	
	7.5	67	0.81		10	0.09	5.5				
	10	50	0.79		14	0.09	4.4				
	15	33	0.73		19	0.09	3.1				
	20	25	0.70		24	0.09	2.3				
	25	20	0.65		28	0.09	1.7				
	30	17	0.61		31	0.09	1.8				
	40	13	0.57		39	0.09	1.3				
	50	10	0.51		44	0.09	1.2				
	65	8	0.46		52	0.09	0.9				
	80	6	0.44		61*	0.09	0.7*				
100	5	0.41	71*	0.09	0.4*	—	—	56			

* **ATTENZIONE:** la coppia massima utilizzabile [T_{2M}] deve essere calcolata utilizzando il fattore di servizio: T_{2M} = T₂ x FS'

* **WARNING:** Maximum allowable torque [T_{2M}] must be calculated using the following service factor: T_{2M} = T₂ x FS'

* **ACHTUNG:** das max. anwendbare Drehmoment [T_{2M}] muss mit folgendem Betriebsfaktor berechnet werden: T_{2M} = T₂ x FS'

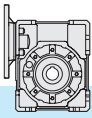

5.10 Dati tecnici

5.10 Technical data

5.10 Technische Daten

GXC 50	n₁ = 2800				MOTORI / MOTORS / ENGINE GHA CLASSIC						
	i _n	n ₂ [min ⁻¹]	Rd	P ₁₀	T ₂ [Nm]	P ₁ [kW]	FS'	Input - IEC			
								B5/B14			
Kg 4.0	5	560	0.89	—	22.8	1.5	1.9	80	71	—	
	7.5	373	0.88		34	1.5	1.5				
	10	280	0.86		44	1.5	1.2				
	15	187	0.84		47	1.1	1.2				
	20	140	0.81		42	0.75	1.4				
	25	112	0.78		50	0.75	1.0				
	30	93	0.75		42	0.55	1.3				
	40	70	0.72		54	0.55	1.0				
	50	56	0.68		43	0.37	1.3				
	65	43	0.64		53	0.37	1.0				
	80	35	0.61		41	0.25	1.2				
100	28	0.58	35	0.18	1.3	—	63				

GXC 50	n₁ = 1400				MOTORI / MOTORS / ENGINE GHA CLASSIC						
	i _n	n ₂ [min ⁻¹]	Rd	P ₁₀	T ₂ [Nm]	P ₁ [kW]	FS'	Input - IEC			
								B5/B14			
Kg 4.0	5	280	0.87	1.2	26.7	0.9	2.3	80	71	—	
	7.5	187	0.86	1.2	40	0.9	1.8				
	10	140	0.84	1.0	52	0.9	1.4				
	15	93	0.80	0.80	74	0.9	1.0				
	20	70	0.78	0.70	58	0.55	1.3				
	25	56	0.74	0.60	47	0.37	1.4				
	30	47	0.71	0.60	53	0.37	1.2				
	40	35	0.67	0.50	68	0.37	1.0				
	50	28	0.62	0.40	53	0.25	1.3				
	65	22	0.58	0.40	64	0.25	1.0				
	80	18	0.54	0.40	53	0.18	1.1				
100	14	0.51	0.30	45	0.13	1.2	—	63			

GXC 50	n₁ = 900				MOTORI / MOTORS / ENGINE GHA CLASSIC						
	i _n	n ₂ [min ⁻¹]	Rd	P ₁₀	T ₂ [Nm]	P ₁ [kW]	FS'	Input - IEC			
								B5/B14			
Kg 4.0	5	180	0.85	—	33.8	0.75	2.2	80	71	—	
	7.5	120	0.84		50	0.75	1.6				
	10	90	0.82		66	0.75	1.3				
	15	60	0.78		68	0.55	1.3				
	20	45	0.75		59	0.37	1.5				
	25	36	0.71		70	0.37	1.1				
	30	30	0.67		79	0.37	1.0				
	40	23	0.63		67	0.25	1.1				
	50	18	0.59		78	0.25	1.0				
	65	14	0.54		67	0.18	1.1				
	80	11	0.51		56	0.13	1.2				
100	9	0.47	45	0.09	1.3	—	63				

GXC 50	n₁ = 500				MOTORI / MOTORS / ENGINE GHA CLASSIC						
	i _n	n ₂ [min ⁻¹]	Rd	P ₁₀	T ₂ [Nm]	P ₁ [kW]	FS'	Input - IEC			
								B5/B14			
Kg 4.0	5	100	0.84	—	14.3	0.18	6.4	80	71	—	
	7.5	67	0.82		21	0.18	4.7				
	10	50	0.80		28	0.18	3.8				
	15	33	0.75		39	0.18	2.7				
	20	25	0.72		50	0.18	2.1				
	25	20	0.68		58	0.18	1.5				
	30	17	0.63		65	0.18	1.5				
	40	13	0.59		81	0.18	1.2				
	50	10	0.54		93	0.18	1.0				
	65	8	0.50		56	0.09	1.5				
	80	6	0.46		63	0.09	1.2				
100	5	0.43	74	0.09	0.8	—	63				

* **ATTENZIONE:** la coppia massima utilizzabile [T_{2M}] deve essere calcolata utilizzando il fattore di servizio: T_{2M} = T₂ x FS'

* **WARNING:** Maximum allowable torque [T_{2M}] must be calculated using the following service factor: T_{2M} = T₂ x FS'

* **ACHTUNG:** das max. anwendbare Drehmoment [T_{2M}] muss mit folgendem Betriebsfaktor berechnet werden: T_{2M} = T₂ x FS'

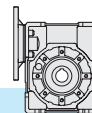

5.10 Dati tecnici

5.10 Technical data

5.10 Technische Daten

GXC 63	n₁ = 2800				MOTORI / MOTORS / ENGINE GHA CLASSIC						
	i _n	n ₂ [min ⁻¹]	Rd	P ₁₀	T ₂ [Nm]	P ₁ [kW]	FS'	Input - IEC			
								B5/B14			
Kg 6.6	5	560	0.89	—	45.5	3	1.7	90	80	—	
	7.5	373	0.88		68	3	1.3				
	10	280	0.87		89	3	1.1				
	15	187	0.84		95	2.2	1.0				
	20	140	0.83		85	1.5	1.3				
	25	112	0.81		76	1.1	1.2				
	30	93	0.77		87	1.1	1.3				
	40	70	0.74		111	1.1	1.1	—	80	71	
	50	56	0.70		90	0.75	1.1				
	65	43	0.67		81	0.55	1.2				
	80	35	0.64		65	0.37	1.4				
	100	28	0.60		75	0.37	1.1				

GXC 63	n₁ = 1400				MOTORI / MOTORS / ENGINE GHA CLASSIC						
	i _n	n ₂ [min ⁻¹]	Rd	P ₁₀	T ₂ [Nm]	P ₁ [kW]	FS'	Input - IEC			
								B5/B14			
Kg 6.6	5	280	0.88	1.8	54	1.8	2.0	90	80	—	
	7.5	187	0.87	1.8	80	1.8	1.5				
	10	140	0.85	1.6	105	1.8	1.2				
	15	93	0.81	1.2	125	1.5	1.1				
	20	70	0.80	1.2	120	1.1	1.2				
	25	56	0.77	1.0	118	0.9	1.0				
	30	47	0.73	0.90	134	0.9	1.1	—	80	71	
	40	35	0.69	0.80	142	0.75	1.1				
	50	28	0.65	0.70	122	0.55	1.0				
	65	22	0.61	0.60	100	0.37	1.2				
	80	18	0.58	0.60	79	0.25	1.4				
	100	14	0.53	0.50	91	0.25	1.1				

GXC 63	n₁ = 900				MOTORI / MOTORS / ENGINE GHA CLASSIC						
	i _n	n ₂ [min ⁻¹]	Rd	P ₁₀	T ₂ [Nm]	P ₁ [kW]	FS'	Input - IEC			
								B5/B14			
Kg 6.6	5	180	0.87	—	69	1.5	1.9	90	80	—	
	7.5	120	0.85		102	1.5	1.4				
	10	90	0.83		133	1.5	1.1				
	15	60	0.79		139	1.1	1.1				
	20	45	0.77		123	0.75	1.4				
	25	36	0.74		109	0.55	1.3				
	30	30	0.70		122	0.55	1.3	—	80	71	
	40	23	0.66		154	0.55	1.1				
	50	18	0.61		120	0.37	1.2				
	65	14	0.57		98	0.25	1.4				
	80	11	0.54		115	0.25	1.1				
	100	9	0.50		95	0.18	1.2				

GXC 63	n₁ = 500				MOTORI / MOTORS / ENGINE GHA CLASSIC						
	i _n	n ₂ [min ⁻¹]	Rd	P ₁₀	T ₂ [Nm]	P ₁ [kW]	FS'	Input - IEC			
								B5/B14			
Kg 6.6	5	100	0.85	—	20	0.25	8.3	90	80	—	
	7.5	67	0.83		30	0.25	5.9				
	10	50	0.81		39	0.25	4.7				
	15	33	0.76		55	0.25	3.4				
	20	25	0.74		71	0.25	2.8				
	25	20	0.71		85	0.25	1.9				
	30	17	0.65		94	0.25	2.1	—	80	71	
	40	13	0.62		118	0.25	1.7				
	50	10	0.56		135	0.25	1.2				
	65	8	0.52		163	0.25	1.0				
	80	6	0.50		137	0.18	1.1				
	100	5	0.45		77	0.09	1.6				

* **ATTENZIONE:** la coppia massima utilizzabile [T_{2M}] deve essere calcolata utilizzando il fattore di servizio: T_{2M} = T₂ x FS'

* **WARNING:** Maximum allowable torque [T_{2M}] must be calculated using the following service factor : T_{2M} = T₂ x FS'

* **ACHTUNG:** das max. anwendbare Drehmoment [T_{2M}] muss mit folgendem Betriebsfaktor berechnet werden: T_{2M} = T₂ x FS'

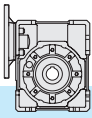

5.10 Dati tecnici

5.10 Technical data

5.10 Technische Daten

GXC 75	$n_1 = 2800$				MOTORI / MOTORS / ENGINE GHA CLASSIC						
	i_n	n_2 [min ⁻¹]	Rd	P_{t0}	T_2 [Nm]	P_1 [kW]	FS'	Input - IEC B5/B14			
Kg 9.5	7.5	373	0.89	—	125	5.5	1.0	112 100	90	—	—
	10	280	0.88		120	4	1.2				
	15	187	0.85		131	3	1.2				
	20	140	0.84		171	3	1.0				
	25	112	0.82		154	2.2	1.0				
	30	93	0.78		120	1.5	1.4	—	80	71	
	40	70	0.75		154	1.5	1.2				
	50	56	0.73		136	1.1	1.2				
	65	43	0.69		114	0.75	1.4				
	80	35	0.66		135	0.75	1.1				
	100	28	0.62		159	0.75	0.8				

GXC 75	$n_1 = 1400$				MOTORI / MOTORS / ENGINE GHA CLASSIC						
	i_n	n_2 [min ⁻¹]	Rd	P_{t0}	T_2 [Nm]	P_1 [kW]	FS'	Input - IEC B5/B14			
Kg 9.5	7.5	187	0.87	2.5	178	4	1.0	112 100	90	—	—
	10	140	0.86	2.3	176	3	1.1				
	15	93	0.83	1.9	187	2.2	1.1				
	20	70	0.81	1.7	199	1.8	1.1				
	25	56	0.78	1.5	200	1.5	1.0				
	30	47	0.74	1.2	167	1.1	1.3	—	80	71	
	40	35	0.71	1.1	213	1.1	1.1				
	50	28	0.67	1.0	206	0.9	1.0				
	65	22	0.63	0.90	154	0.55	1.3				
	80	18	0.60	0.80	180	0.55	1.0				
	100	14	0.56	0.70	210	0.55	0.8				

GXC 75	$n_1 = 900$				MOTORI / MOTORS / ENGINE GHA CLASSIC						
	i_n	n_2 [min ⁻¹]	Rd	P_{t0}	T_2 [Nm]	P_1 [kW]	FS'	Input - IEC B5/B14			
Kg 9.5	7.5	120	0.86	—	205	3	1.0	112 100	90	—	—
	10	90	0.84		197	2.2	1.2				
	15	60	0.81		231	1.8	1.0				
	20	45	0.78		250	1.5	1.1				
	25	36	0.76		221	1.1	1.1				
	30	30	0.71		249	1.1	1.0	—	80	71	
	40	23	0.67		214	0.75	1.3				
	50	18	0.64		186	0.55	1.3				
	65	14	0.59		151	0.37	1.5				
	80	11	0.56		177	0.37	1.2				
	100	9	0.52		203	0.37	0.9				

GXC 75	$n_1 = 500$				MOTORI / MOTORS / ENGINE GHA CLASSIC						
	i_n	n_2 [min ⁻¹]	Rd	P_{t0}	T_2 [Nm]	P_1 [kW]	FS'	Input - IEC B5/B14			
Kg 9.5	7.5	67	0.84	—	90	0.75	2.9	112 100	90	—	—
	10	50	0.82		118	0.75	2.4				
	15	33	0.78		167	0.75	1.7				
	20	25	0.75		216	0.75	1.5				
	25	20	0.72		260	0.75	1.1				
	30	17	0.67		288	0.75	1.1	—	80	71	
	40	13	0.63		265	0.55	1.2				
	50	10	0.59		210	0.37	1.3				
	65	8	0.55		251	0.37	1.0				
	80	6	0.52		197	0.25	1.2				
	100	5	0.47		161	0.18	1.3				

* **ATTENZIONE:** la coppia massima utilizzabile $[T_{2M}]$ deve essere calcolata utilizzando il fattore di servizio: $T_{2M} = T_2 \times FS'$

* **WARNING:** Maximum allowable torque $[T_{2M}]$ must be calculated using the following service factor: $T_{2M} = T_2 \times FS'$

* **ACHTUNG:** das max. anwendbare Drehmoment $[T_{2M}]$ muss mit folgendem Betriebsfaktor berechnet werden: $T_{2M} = T_2 \times FS'$

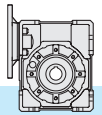



5.10 Dati tecnici

5.10 Technical data

5.10 Technische Daten

GXC 89	$n_1 = 2800$				MOTORI / MOTORS / ENGINE GHA CLASSIC							
	i_n	n_2 [min ⁻¹]	Rd	P_{10}	T_2 [Nm]	P_1 [kW]	FS'	Input - IEC				
								B5/B14				
 23.6	7.5	373	0.89	—	171	7.5	1.2	112 100	90	—		
	10	280	0.88		165	5.5	1.3					
	15	187	0.86		241	5.5	1.0					
	20	140	0.84		230	4	1.2					
	25	112	0.83		212	3	1.2					
	30	93	0.79		243	3	1.1					
	40	70	0.77		230	2.2	1.3	—	80			
	50	56	0.74		278	2.2	1.0					
	65	43	0.71		235	1.5	1.1					
	80	35	0.68		205	1.1	1.2					
100	28	0.64	163	0.75	1.3							

GXC 89	$n_1 = 1400$				MOTORI / MOTORS / ENGINE GHA CLASSIC							
	i_n	n_2 [min ⁻¹]	Rd	P_{10}	T_2 [Nm]	P_1 [kW]	FS'	Input - IEC				
								B5/B14				
 23.6	7.5	187	0.88	3.0	247	5.5	1.2	112 100	90	—		
	10	140	0.86	2.5	236	4	1.3					
	15	93	0.84	2.2	256	3	1.2					
	20	70	0.82	2.0	334	3	1.1					
	25	56	0.80	1.8	299	2.2	1.1					
	30	47	0.76	1.5	340	2.2	1.0					
	40	35	0.72	1.3	355	1.8	1.1	—	80			
	50	28	0.69	1.1	353	1.5	1.0					
	65	22	0.65	1.0	317	1.1	1.0					
	80	18	0.63	1.0	309	0.9	1.0					
100	14	0.58	0.80	217	0.55	1.2						

GXC 89	$n_1 = 900$				MOTORI / MOTORS / ENGINE GHA CLASSIC							
	i_n	n_2 [min ⁻¹]	Rd	P_{10}	T_2 [Nm]	P_1 [kW]	FS'	Input - IEC				
								B5/B14				
 23.6	7.5	120	0.86	—	206	3	1.7	112 100	90	—		
	10	90	0.85		270	3	1.3					
	15	60	0.82		286	2.2	1.3					
	20	45	0.79		371	2.2	1.1					
	25	36	0.77		369	1.8	1.0					
	30	30	0.73		416	1.8	1.0					
	40	23	0.69		440	1.5	1.0	—	80			
	50	18	0.66		384	1.1	1.0					
	65	14	0.62		319	0.75	1.1					
	80	11	0.59		274	0.55	1.2					
100	9	0.54	313	0.55	1.0							

GXC 89	$n_1 = 500$				MOTORI / MOTORS / ENGINE GHA CLASSIC							
	i_n	n_2 [min ⁻¹]	Rd	P_{10}	T_2 [Nm]	P_1 [kW]	FS'	Input - IEC				
								B5/B14				
 23.6	7.5	67	0.84	—	91	0.75	4.7	112 100	90	—		
	10	50	0.83		118	0.75	3.7					
	15	33	0.79		169	0.75	2.7					
	20	25	0.76		219	0.75	2.3					
	25	20	0.74		265	0.75	1.7					
	30	17	0.68		294	0.75	1.6					
	40	13	0.65		371	0.75	1.4	—	80			
	50	10	0.61		439	0.75	1.1					
	65	8	0.57		388	0.55	1.1					
	80	6	0.54		305	0.37	1.3					
100	5	0.49	344	0.37	1.0							

* **ATTENZIONE:** la coppia massima utilizzabile $[T_{2M}]$ deve essere calcolata utilizzando il fattore di servizio: $T_{2M} = T_2 \times FS'$

* **WARNING:** Maximum allowable torque $[T_{2M}]$ must be calculated using the following service factor: $T_{2M} = T_2 \times FS'$

* **ACHTUNG:** das max. anwendbare Drehmoment $[T_{2M}]$ muss mit folgendem Betriebsfaktor berechnet werden: $T_{2M} = T_2 \times FS'$

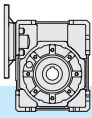

5.11 **Momenti d'inerzia** [Kg·cm²]
(riferiti all'albero veloce in entrata)

5.11 **Moments of inertia** [Kg·cm²]
(referred to input shaft)

5.11 **Trägheitsmoment** [Kg·cm²]
(bez. Antriebswelle)

GX30	i_n	GGXC	
		B5 - B14	
		IEC 56	IEC 63
5		0.130	0.127
7.5		0.112	0.109
10		0.103	0.100
15		0.097	0.094
20		0.095	0.092
25		0.094	0.091
30		0.093	0.090
40		0.093	0.090
50		0.092	0.089
65		0.079	-
80		0.079	-
100		0.078	-

GX63	i_n	GXC		
		B5 - B14		
		IEC 71	IEC 80	IEC 90
5		-	2.431	2.671
7.5		-	1.949	2.269
10		-	1.744	2.063
15		-	1.597	1.916
20		-	1.545	1.864
25		-	1.514	1.833
30		-	1.508	1.828
40		0.966	1.495	-
50		0.959	1.488	-
65		0.955	1.484	-
80		0.953	1.482	-
100		0.952	1.481	-

GX40	i_n	GXC		
		B5 - B14		
		IEC 56	IEC 63	IEC 71
5		-	0.391	0.463
7.5		-	0.321	0.356
10		-	0.272	0.347
15		-	0.266	0.340
20		-	0.263	0.338
25		-	0.262	0.337
30		-	0.262	0.337
40		-	0.261	0.336
50		0.182	0.261	-
65		0.182	0.261	-
80		0.182	0.261	-
100		0.182	0.261	-

GK75	i_n	GKC			
		B5 - B14			
		IEC 71	IEC 80	IEC 90	IEC 100-112
7.5		-	-	3.712	4.462
10		-	-	3.234	3.984
15		-	-	2.893	3.643
20		-	-	2.774	3.523
25		-	-	2.709	3.458
30		1.615	1.575	2.689	3.438
40		-	1.573	2.659	-
50		-	1.570	2.642	-
65		1.609	1.569	2.633	-
80		1.605	1.565	2.629	-
100		1.602	1.562	2.626	-

GX50	i_n	GXC		
		B5 - B14		
		IEC 63	IEC 71	IEC 80
5		-	0.922	1.046
7.5		-	0.684	0.935
10		-	0.602	0.853
15		-	0.543	0.794
20		-	0.523	0.774
25		-	0.513	0.764
30		-	0.508	0.759
40		0.315	0.503	0.755
50		0.313	0.501	-
65		0.311	0.499	-
80		0.310	0.498	-
100		0.309	0.498	-

GX89	i_n	GXC		
		B5 - B14		
		IEC 80	IEC 90	IEC 100-112
7.5		-	6.898	7.671
10		-	5.875	6.648
15		-	5.144	5.917
20		-	3.398	5.661
25		-	3.256	5.520
30		-	3.215	5.479
40		-	3.151	-
50		-	3.115	-
65		2.024	3.096	-
80		2.014	3.087	-
100		2.008	3.080	-

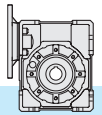

5.12 Dimensioni

5.12 Dimensions

5.12 Abmessungen

GXC

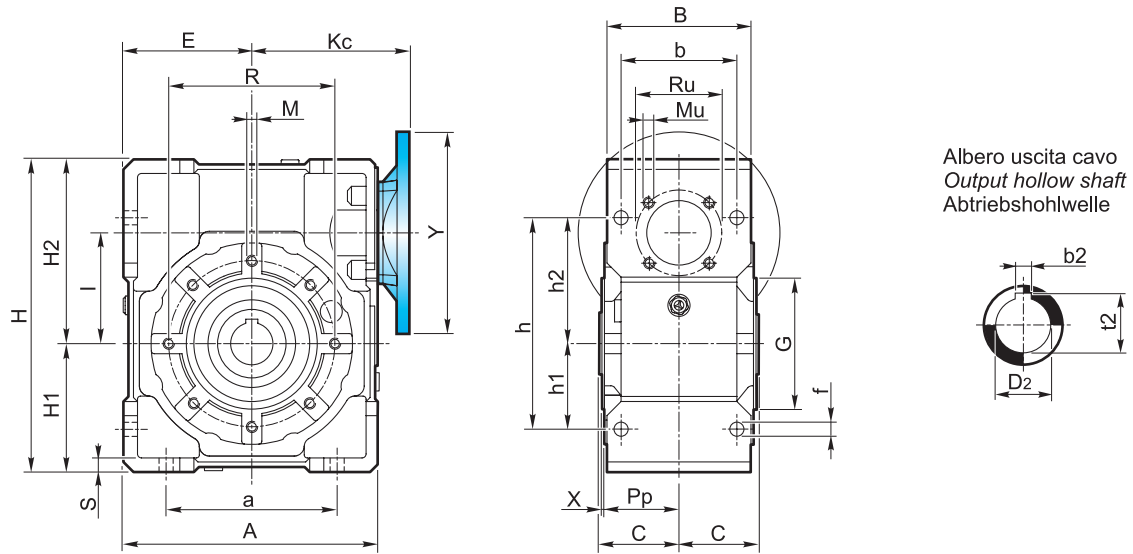

Flangia pendolare / Shaft-mounted flange / Aufsteckflansch

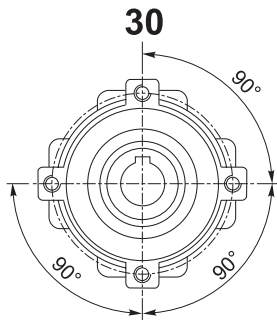

4 Fori / Holes / Bohrungen

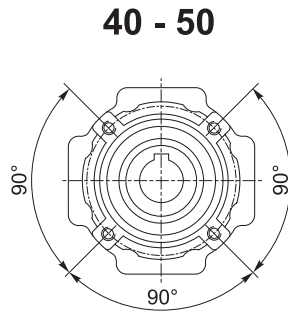

4 Fori / Holes / Bohrungen

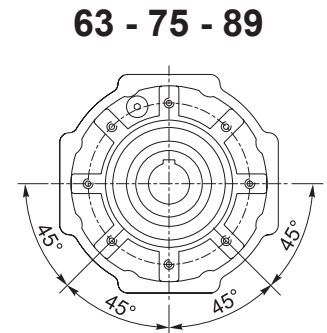

8 Fori / Holes / Bohrungen

GX	A	a	B	b	b ₂	C	D ₂ H ₈	E	f	G h ₈	H	H ₁	H ₂	h	h ₁	h ₂
30	80	54	56	44	5	31.5	14	40	6.5	55	97	40	57	71	27	44
40	105	70	71	60	6	39	18	50	6.5	60	125	50	75	90	35	55
50	125	80	85	70	8	46	25	60	8.5	70	150	60	90	104	40	64
63	147	100	103	85	8	56	25	72	9	80	182	72	110	130	50	80
75	176	120	112	90	8	60	28	86	11	95	219.5	86	133.5	153	60	93
89	203	140	130	100	10	70	35	103	13	110	248.5	103	145.5	172	70	102

GX	I	K _c	L	M	M _u	P _p	R	Ru	S	t ₂	X
30	31.5	57	15	M6x8	M5x7.5	29	65	35.4	5.5	16.3	1.5
40	40	75	20	M6x10	M5x10	36.5	75	42.4	6	20.8	1.5
50	50	82	25	M8x10	M6x10	43.5	85	53.7	7	28.3	1.5
63	63	95	30	M8x14	M6x12	53	95	60.8	8	28.3	2
75	75	112 - 110 ⁽¹⁾	40	M8x14	M8x12	57	115	70.7	10	31.3	2
89	90	122	40	M10x18	M8x14	67	130	70.7	12	38.3	2

(1): Solo per PAM 71B14 / Only for PAM 71B14 / Nur PAM 71B14

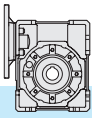

5.12 Dimensioni

5.12 Dimensions

5.12 Abmessungen

Flangia uscita / Output flange / Abtriebsflansch

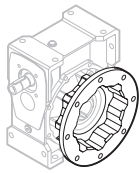
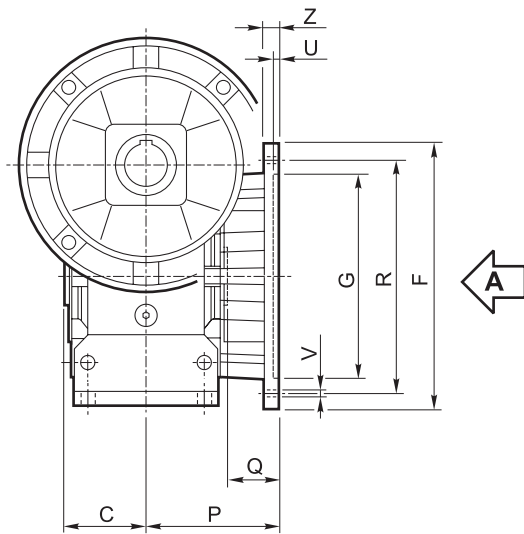

F...D
Standard

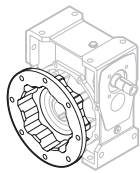

F...S

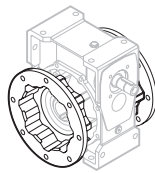

F...2

Vista da A / View from A / Ansicht von A

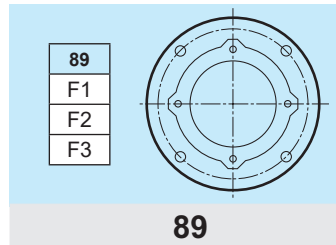
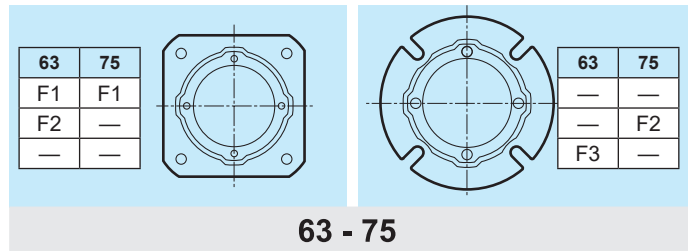
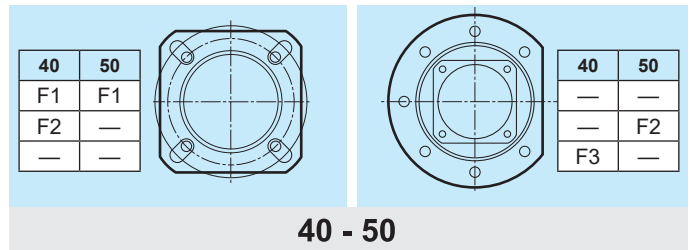
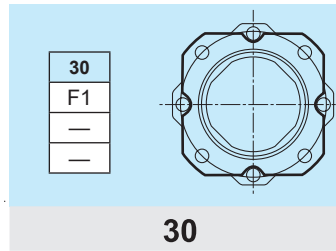

Tipo Type Typ	C	F		G H8	P	Q	R	U	V			Z
											Ø	
30	31.5		66	50	54.5	23	68	4	n° 4		6.5	6
40	39		85	60	67	28	75-90	4	n° 4		9	8
			85	60	97	58	75-90	4	n° 4		9	8
		140		95	80	41	115	5		n° 7	9	10
50	46		94	70	90	44	85-100	5	n° 4		11	10
		160		110	89	43	130	5		n° 7	11	11
63	56		142	115	82	26	150	5	n° 4		11	11
			142	115	112	56	150	5	n° 4		11	11
		160		110	80.5	24.5	130	5	n° 4		11	12
75	60		160	130	111	51	165	5	n° 4		13	12
		160		110	90	30	130	6	n° 4		11	13
89	70		200	152	111	41	175	5	n° 4		13	12
			200	152	151	81	175	5	n° 4		13	13
			200	130	110	40	165	6	n° 4		11	11

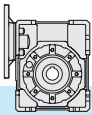

5.13 Entrata supplementare
(vite bisporgente)

5.13 Additional input
(double extended shaft)

5.13 Zusatzantrieb
(beidseitige Welle)

S.e.A.

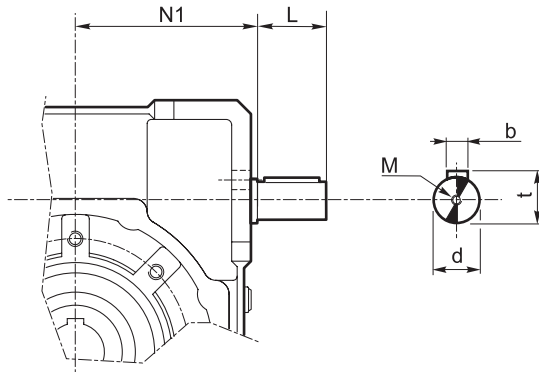

GX	d j6	L	M	N1	b	t
30	9	15	M4x10	42.5	3	10.2
40	11	20	M4x12	52.5	4	12.5
50	14	25	M5x13	62.5	5	16
63	19	30	M8x20	74.5	6	21.5
75	24	40	M8x20	91	8	27
89	24	40	M8x20	108	8	27

5.14 Lista parti di ricambio

5.14 Spare parts list

5.14 Ersatzteilliste

In fase di ordine delle parti di ricambio, specificare sempre n° particolare (vedi disegno esploso), data (1), n° codice (2) e n° variante (3).
(Vedi targhetta).

When ordering a spare part, the spare part number (see exploded technical drawing), the date (1), the code number (2) and the variant number (3) should always be reported.
(See plate)

Bei der Bestellung von Ersatzteilen sind Ersatzteilnummer (s. Explosionszeichnung), Datum (1), Artikelnummer (2) und Variantennummer (3) anzugeben.
(s. Schild)

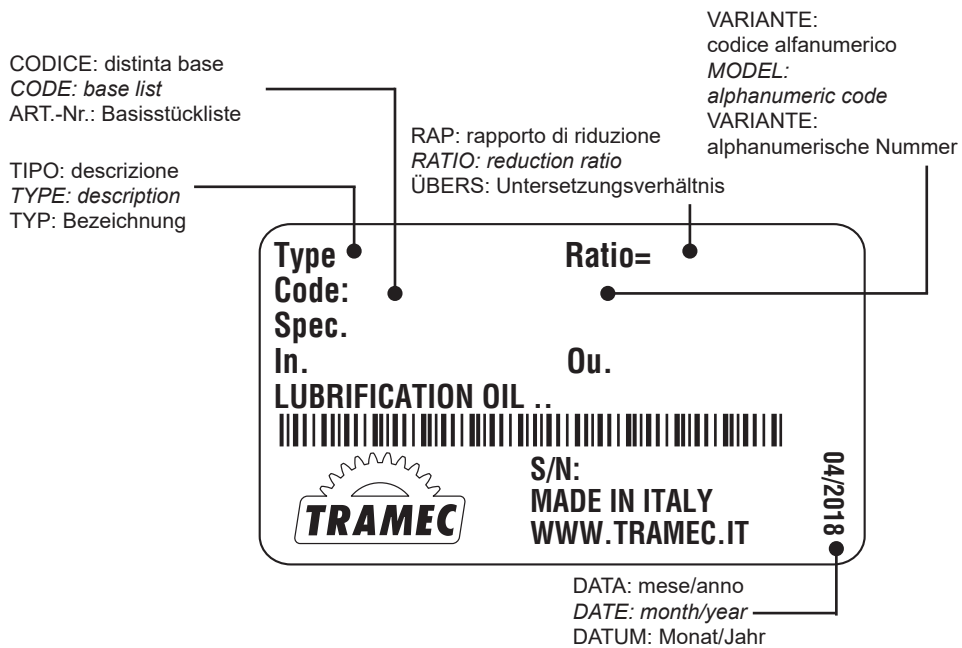

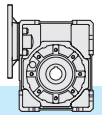

5.14 Lista parti di ricambio

5.14 Spare parts list

5.14 Ersatzteilliste

GXC

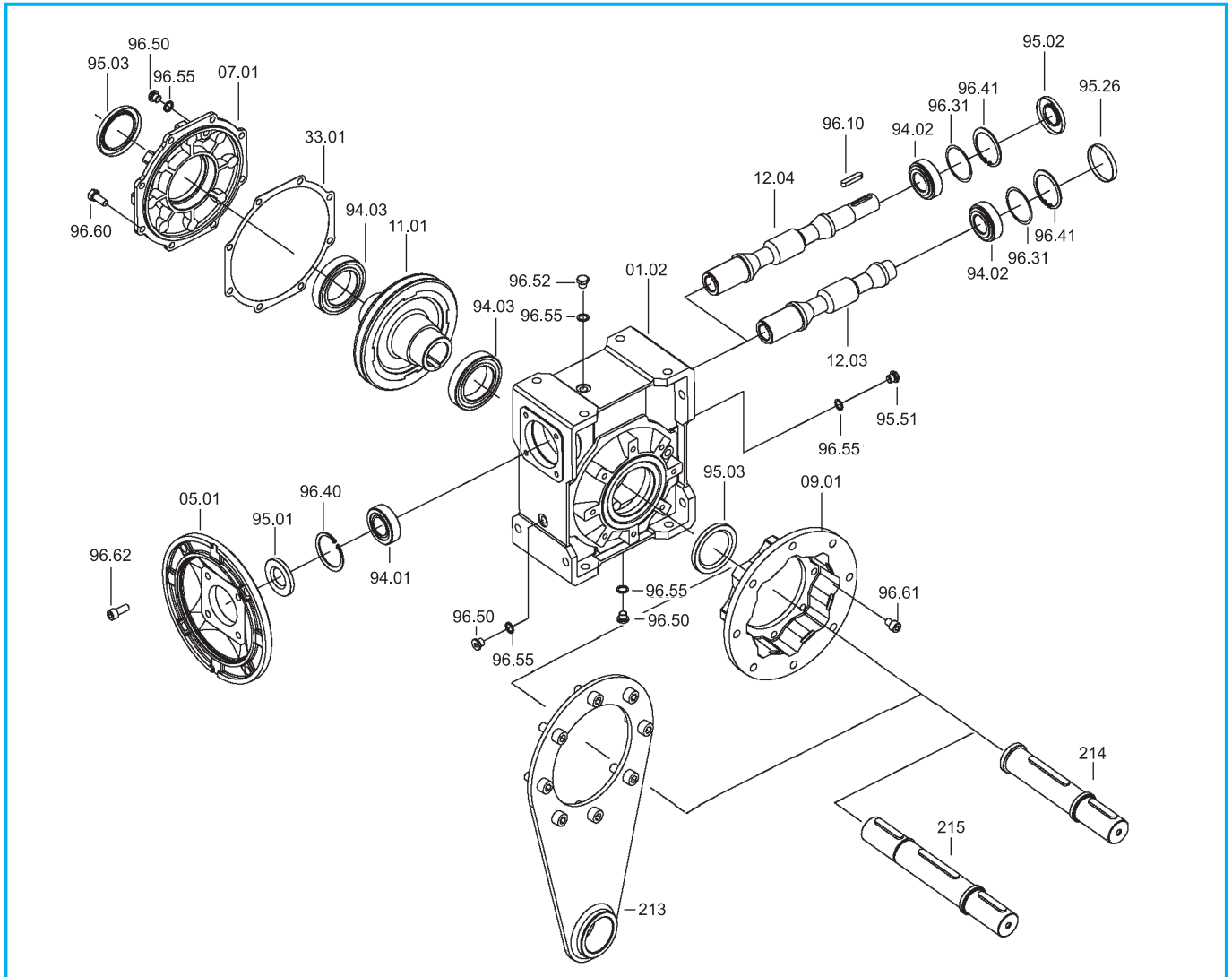

GX	IEC	Cuscinetti / Bearings / Lager			Anelli di tenuta / Oilseals Öldichtungen			Cappellotto / Closed oil seal Geschlossene Öldichtung
		94.01	94.02	94.03	95.01	95.02	95.03	95.26
30	56	61804 (20x32x7)	6000 10x26x8	6005 25x47x12	20/32/5	10/26/7	25/40/7	ø 26x7
	63	61804 (20x32x7)			20/32/5			
40	56	6303 (17x47x14)	6201 12x32x10	6006 30x55x13	17/47/7	12/32/7	30/47/7	ø 32x7
	63	6204 (20x47x14)			20/47/7			
	71	6005 (25x47x12)			25/47/7			
50	63	6204 (20x47x14)	6203 17x40x12	6008 40x68x15	20/47/7	17/40/7	40/62/8	ø 40x7
	71	6005 (25x47x12)			25/47/7			
	80	6006 (30x55x13)			30/55/7			
63	71	6305 (25x62x17)	6204 C3 20x47x14	6008 40x68x15	25/62/7	20/47/7	40/62/8	ø 47x7
	80	6206 (30x62x16)			30/62/7			
	90	6007 (35x62x14)			35/62/7			
75	71	6206 (30x62x16)	6205 C3 25x52x15	6010 50x80x16	30/62/7	25/52/7	50/72/8	ø 52x7
	80	6206 (30x62x16)			30/62/7			
	90	6007 (35x62x14)			35/62/7			
	100/112	6008 (40x68x15)			40/68/10			
89	80	6206 (30x62x16)	6205 C3 25x52x15	6010 50x80x16	30/62/7	25/52/7	50/72/8	ø 52x7
	90	6007 (35x62x14)			35/62/7			
	100/112	6008 (40x68x15)			40/68/10			

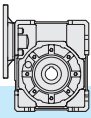



6.0	MOTORI MHA PREMIUM	MHA PREMIUM MOTORS	ENGINES MHA PREMIUM	
6.1	Caratteristiche	<i>Characteristics</i>	Merkmale	92
6.2	Dati tecnici	<i>Technical data</i>	Technische Daten	93
6.3	Dimensioni	<i>Dimensions</i>	Abmessungen	93

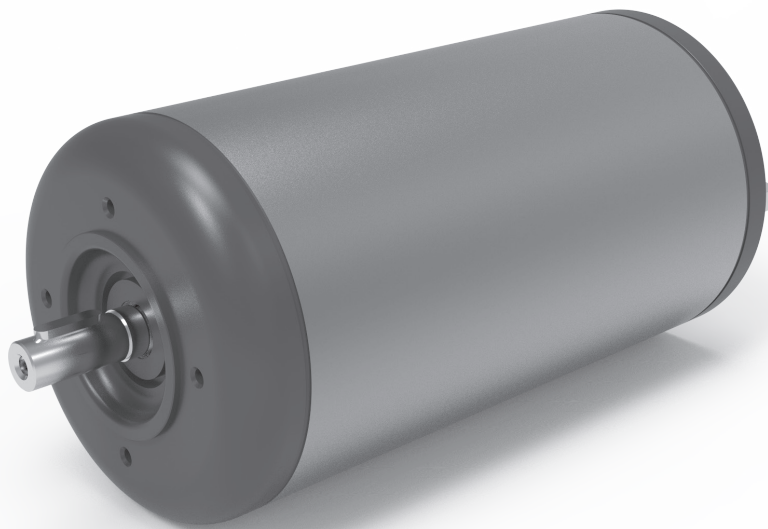

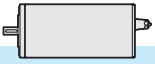

6.1 Caratteristiche

La nuova gamma GHA include i motori MHA PREMIUM (classe energetica IE4) dotati, analogamente ai riduttori della serie GHA PREMIUM, di carcassa in lega di alluminio sottoposta a trattamento GHA potenziato.

Il corpo di questi motori presenta, inoltre, uno speciale profilo esterno liscio appositamente progettato per consentirne la massima pulizia (vedi sezione pulizia del prodotto).

Ideale complemento dei riduttori GHA PREMIUM, i motori MHA PREMIUM presentano le seguenti caratteristiche speciali, che si sommano alle caratteristiche NANOTECHNOLOGICHE già descritte per i riduttori GHA PREMIUM (eccellenti proprietà battericide e anticorrosive):

- Dissipazione termica superiore al 35% rispetto alla versione senza trattamento GHA
- Maggiore efficienza del motore, in virtù della maggiore dissipazione termica
- Capacità di sopportare elevati voltaggi, grazie alle caratteristiche amagnetiche

I motori MHA PREMIUM, come tutti i motori e riduttori della gamma GHA, sono NICKEL-FREE.

In virtù delle loro speciali caratteristiche, i motori MHA PREMIUM costituiscono la soluzione ideale per applicazioni in campo alimentare (non a contatto con gli alimenti), farmaceutico e marino.

6.1 Caratteristiche

Similarly to the GHA PREMIUM series reducers, the new GHA range includes MHA PREMIUM motors (energy class IE4) equipped with an aluminium alloy casing subjected to enhanced GHA treatment.

The body of these motors also has a special smooth external profile specially designed to allow for maximum cleanliness (see the product cleaning section).

The ideal complement to GHA PREMIUM reducers is the MHA PREMIUM motor that has the following special features, which are added to the NANOTECHNOLOGICAL characteristics already described for the GHA PREMIUM reducers (excellent bactericidal and anticorrosive properties):

- Thermal dissipation 35% greater than the version without GHA treatment*
- Greater motor efficiency thanks to the higher heat dissipation*
- Ability to withstand high voltages, thanks to the non-magnetic characteristics*

Like all motors and reducers in the GHA range, MHA PREMIUM motors are NICKEL-FREE.

Thanks to their special characteristics, MHA PREMIUM motors are the ideal solution for applications in the food (not in contact with food), pharmaceutical and marine sectors.

6.1 Caratteristiche

Die neue GHA-Serie umfasst auch die Motoren MHA PREMIUM (Effizienzklasse IE4), die genau wie die Getriebe der Serie GHA PREMIUM mit einem Aluminiumgehäuse ausgestattet sind, das einer verstärkten GHA-Behandlung unterzogen wurde.

Das Gehäuse dieser Motoren weist ein spezielles, glattes Außenprofil auf, das eigens dafür entwickelt wurde, um die bestmögliche Reinigung zu gewährleisten (siehe Abschnitt Reinigung des Produkts).

Die Motoren MHA PREMIUM sind die ideale Ergänzung zu den Getrieben GHA PREMIUM und weisen die folgenden speziellen Merkmale auf, die zu den für die Getriebe GHA PREMIUM bereits beschriebenen NANOTECHNOLOGISCHEN Merkmalen (ausgezeichnete bakterientötende Wirkung und Korrosionsbeständigkeit) hinzu kommen:

- Um mehr als 35 % gesteigerte Wärmeableitung im Vergleich zu den Ausführungen ohne GHA-Behandlung
- Höhere Leistungsfähigkeit des Motors dank der besseren Wärmeableitung
- Fähigkeit hohe Stromstärken auszuhalten dank den nichtmagnetischen Merkmalen

Die Motoren MHA PREMIUM sind wie alle anderen Motoren und Getriebe der Baureihe GHA NICKELFREI.

Dank ihren speziellen Merkmalen sind die Motoren MHA PREMIUM die ideale Lösung für Anwendungen in der Lebensmittel- (ohne Kontakt mit den Lebensmitteln), Pharma- und Schifffahrtsbranche.

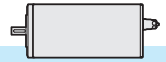

6.2 Dati tecnici

6.2 Technical data

6.2 Technische Daten

IE4	4 POLI / 4 POLES / 4 POLIG								
	P _n (kW)	n ₁ (rpm)	η % 100% P _n	cos φ	I _n (A)	T _n (Nm)	T _{sp} T _n	I _{sp} I _n	Kg
MHA 71 AR MHA 71 AS	0.13	1400	69.8	0.73	0.38	0.88	3.55	6.4	8.8
MHA 71 BR MHA 71 BS	0.18	1420	74.7	0.73	0.49	1.25	3.78	6.4	9.5
MHA 80 AR	0.25	1450	77.9	0.73	0.66	1.66	4.5	7.6	13
MHA 80 BR MHA 80 BS	0.37	1440	81.1	0.79	0.83	2.44	4.63	8.34	14.5
MHA 90 AR MHA 90 AS	0.5	1450	83.9	0.7	1.25	3.3	5.04	8.34	18
MHA 90 BR MHA 90 BS	0.75	1440	85.7	0.75	1.77	5	5.62	7.7	19
MHA 112 AR	1.1	1430	87.2	0.81	2.24	7.34	3.84	7.08	25
MHA 112 BR	1.5	1450	88.2	0.82	3	9.88	3.79	8.71	32

ATTENZIONE: I dati tecnici riportati nelle tabelle si riferiscono ad una tensione di alimentazione di 400 V, 50 Hz.

WARNING: Technical data are referred to voltage 400V, 50Hz.

ACHTUNG: Technische Daten beziehen sich auf Spannung 400V, 50Hz.

6.3 Dimensioni

6.3 Dimensions

6.3 Abmessungen

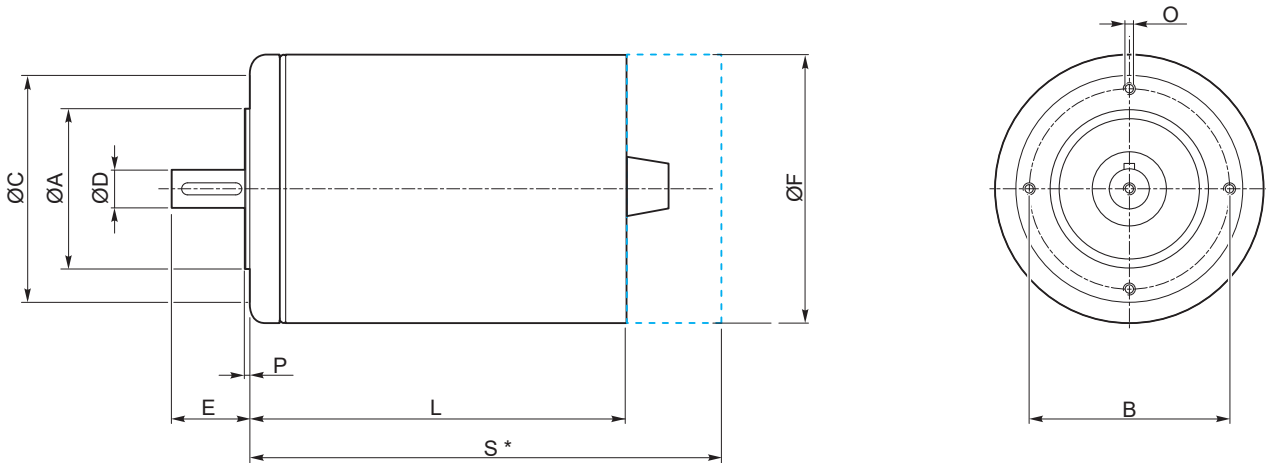

MHA	IEC B14								
	A _{j6}	B	C	D _{j6}	E	F	L	O	P
71 AR 71 BR	60	75	90	11	23	118	223	M5x13	2
71 AS 71 BS	70	85	105	14	30	118	223	M6x13	2.5
80 AR 80 BR	70	85	105	14	30	134	234	M6x13	2.5
80 AS 80 BS	80	100	120	19	40	134	234	M6x13	2.5
90 AR 90 BR	80	100	120	19	40	150	239	M6x13	3
90 AS 90 BS	95	115	140	24	50	150	239	M6x13	3
112 AR 112 BR	95	115	140	24	50	190	307	M8x16	3

*S: quota valida solo per le versioni a richiesta (freno, encodeer, ecc.).

*S: value valid only for the versions on request (brake, encodeer, ecc.).

*S: Wert gilt nur für die Versionen auf Anfrage (Bremsen, Encoder, ecc.).

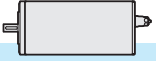

GHA - CLASSIC

La nuova gamma GHA include anche i motori GHA CLASSIC (classe energetica IE1 e IE3) che, analogamente ai riduttori della serie GHA CLASSIC, sono dotati di carcassa in lega di alluminio sottoposta a trattamento GHA standard.

Le carcasse sono del tipo classico alettato, disponibili nelle versioni B5 e B14.

Questi motori, ideale complemento dei riduttori delle serie GHA CLASSIC e GHA MODULAR, presentano le seguenti caratteristiche speciali che si sommano alle caratteristiche NANOTECCNOLOGICHE già descritte per i riduttori GHA CLASSIC e GHA MODULAR (eccellenti proprietà battericide, resistenza standard alla corrosione):

- Dissipazione termica superiore al 35% rispetto alla versione senza trattamento GHA
 - Maggiore efficienza del motore, in virtù della maggiore dissipazione termica
 - Capacità di sopportare elevati voltaggi, grazie alle caratteristiche amagnetiche
- Anche i motori GHA CLASSIC, come tutti i motori e riduttori della gamma GHA, sono NICKEL-FREE.

In virtù delle loro speciali caratteristiche, i motori GHA CLASSIC sono particolarmente idonei per applicazioni in campo alimentare (non a contatto con gli alimenti), farmaceutico.

GHA - CLASSIC

The new GHA range also includes GHA CLASSIC motors (energy class IE1 and IE3) which, like the GHA CLASSIC series reducers, are fitted with an aluminium alloy casing subjected to enhanced GHA treatment.

The casings are of the classic finned type, available in versions B5 and B14.

These motors are the ideal complement to GHA CLASSIC and GHA MODULAR series reducers and feature the following special characteristics on top of the NANOTECHNOLOGICAL characteristics already described for the GHA CLASSIC and GHA MODULAR reducers (excellent bactericidal properties and standard corrosion resistance):

- Thermal dissipation 35% greater than the version without GHA treatment
 - Greater motor efficiency thanks to the higher heat dissipation
 - Ability to withstand high voltages, thanks to the non-magnetic characteristics
- Like all motors and reducers in the GHA range, GHA CLASSIC motors are also NICKEL-FREE.

Thanks to their special characteristics, GHA CLASSIC motors are particularly suitable for applications in the food (not in contact with food), pharmaceutical sectors.

GHA - CLASSIC

Die neue GHA-Serie umfasst auch die Motoren GHA PREMIUM (Effizienzklasse IE1 und IE3), die genau wie die Getriebe der Serie GHA CLASSIC mit einem Aluminiumgehäuse ausgestattet sind, das der standardmäßigen GHA-Behandlung unterzogen wurde.

Die klassischen Rippengehäuse sind in den Ausführungen B5 und B14 erhältlich.

Diese Motoren sind die ideale Ergänzung zu den Getriebe GHA CLASSIC und GHA MODULAR und weisen die folgenden speziellen Merkmale auf, die zu den für die Getriebe GHA CLASSIC und GHA MODULAR bereits beschriebenen NANOTECHNOLOGISCHEN Merkmalen (ausgezeichnete bakterientötende Wirkung und standardmäßige Korrosionsbeständigkeit) hinzu kommen:

- Um mehr als 35 % gesteigerte Wärmeableitung im Vergleich zu den Ausführungen ohne GHA-Behandlung
- Höhere Leistungsfähigkeit des Motors dank der besseren Wärmeableitung
- Fähigkeit hohe Stromstärken auszuhalten dank den nichtmagnetischen Merkmalen

Auch die Motoren GHA CLASSIC sind wie alle anderen Motoren und Getriebe der Baureihe GHA NICKELFREI. Dank ihren speziellen Merkmalen sind die Motoren GHA CLASSIC für Anwendungen in der Lebensmittel- (ohne Kontakt mit den Lebensmitteln), Pharma besonders geeignet.

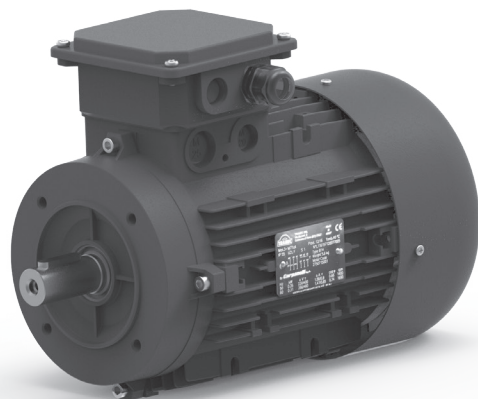
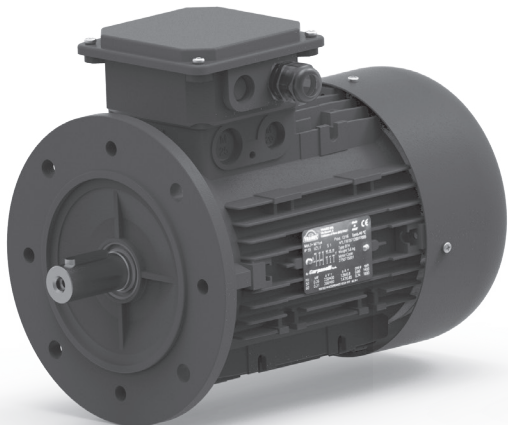

B5

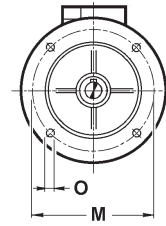
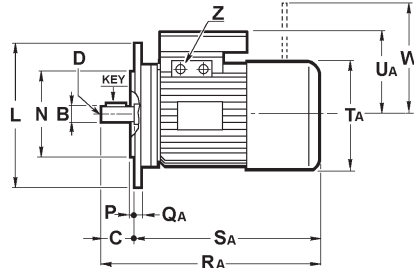
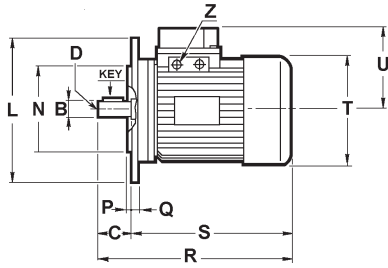

Motori elettrici ⁽¹⁾
Electric motors
Elektromotoren

Motori elettrici autofrenanti ⁽²⁾
Electric brake motors
Elektro-Bremsmotoren

	4 poles	kW	kg. (1)	kg. (2)	B	C	D	L	M	N	O	P	Q	QA	R	RA	S	SA	T	TA	U	UA	W	Z	KEY
56	A	0.06	2.5	4	9	20	M4	120	100	80	7	3	8	8	188	220	167	200	110	110	110	108	90	PG11	3x3x15
	B	0.09	2.6	5																				PG11	3x3x15
	C	0.11	3.2	5																				PG11	3x3x15
63	A	0.13	3.7	5	11	23	M4	140	115	95	9	3	9	9	208	257	193	234	123	123	115	110	98	PG11	4x4x15
	B	0.18	4.3	7																				PG11	
	C	0.22	4.3	7																				PG11	
71	A	0.25	5.8	8	14	30	M5	160	130	110	9	3.5	9	9	245	297	215	267	138	138	124	121	98	PG11	5x5x20
	B	0.37	6.2	8																				PG11	
	C	0.55	7.4	9																				PG11	
80	A	0.55	8.5	11	19	40	M6	200	165	130	11	3.5	10	10	278	336	235	296	156	156	141	138	111	PG16	6x6x30
	B	0.75	9.8	13																				PG16	
	C	0.9	10.5	13.5																				PG16	
90	S	1.1	12	17	24	50	M8	200	165	130	11	3.5	10	10	305	369	250	319	176	176	146	149	129	PG16	8x7x35
	L	1.5	13.5	18											330	394	275	344						PG16	
	LB	1.8	15.5	20											PG16										
100	A	2.2	19	25.5	28	60	M10	250	215	180	14	4	14	14	369	434	305	374	194	194	157	160	139	PG16	8x7x45
	B	3	21	28																				PG16	
	BL	4	23	30																				PG16	
112	A	4	29	38	28	60	M10	250	215	180	14	4	14	14	388	467	325	407	220	220	170	172	161	PG16	8x7x45
	BL	5.5	35	44																				PG16	

Le dimensioni dei motori elettrici sono puramente indicative.

The dimensions of the electric motors are approximate values.

Die Abmessungen der Elektromotoren sind Näherungswerte.

B14

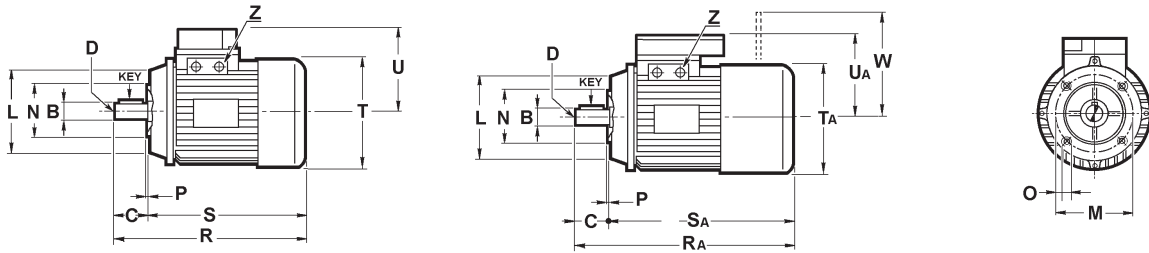

Motori elettrici ⁽¹⁾
Electric motors
Elektromotoren

Motori elettrici autofrenanti ⁽²⁾
Electric brake motors
Elektro-Bremsmotoren

	4 poles	kW	kg. (1)	kg. (2)	B	C	D	L	M	N	O	P	R	RA	S	SA	T	TA	U	UA	W	Z	KEY
56	A	0.06	2.5	4	9	20	M4	80	65	50	M5	2.5	188	220	167	200	110	110	110	108	90	PG11	3x3x15
	B	0.09	2.6	5																		PG11	3x3x15
	C	0.11	3.2	5																		PG11	3x3x15
63	A	0.13	3.7	5	11	23	M4	90	75	60	M5	2.5	208	257	193	234	123	123	115	110	98	PG11	4x4x15
	B	0.18	4.3	7																		PG11	
	C	0.22	4.3	7																		PG11	
71	A	0.25	5.8	8	14	30	M5	105	85	70	M6	2.5	245	297	215	267	138	138	124	121	98	PG11	5x5x20
	B	0.37	6.2	8																		PG11	
	C	0.55	7.4	9																		PG11	
80	A	0.55	8.5	11	19	40	M6	120	100	80	M6	3	278	336	235	296	156	156	141	138	111	PG16	6x6x30
	B	0.75	9.8	13																		PG16	
	C	0.9	10.5	13.5																		PG16	
90	S	1.1	12	17	24	50	M8	140	115	95	M8	3	305	369	250	319	176	176	146	149	129	PG16	8x7x35
	L	1.5	13.5	18									330	394	275	344							
	LB	1.8	15.5	20																			
100	A	2.2	19	25.5	28	60	M10	160	130	110	M8	3.5	369	434	305	374	194	194	157	160	139	PG16	8x7x45
	B	3	21	28																			
	BL	4	23	30																			
112	A	4	29	38	28	60	M10	160	130	110	M8	3.5	388	467	325	407	220	220	170	172	161	PG16	8x7x45
	BL	5.5	35	44																		PG16	8x7x45

Le dimensioni dei motori elettrici sono puramente indicative.

The dimensions of the electric motors are approximate values.

Die Abmessungen der Elektromotoren sind Näherungswerte.

8.0	CONDIZIONI GENERALI DI VENDITA	TERMS AND CONDITIONS OF SALE	
8.1	Scopo	<i>Purpose</i>	100
8.1.1	Modifiche alle condizioni generali di vendita	<i>Modification of the conditions of sale</i>	100
8.2	Definizioni generali	<i>General definitions</i>	100
8.3	Riferimenti	<i>References</i>	100
8.4	Offerte e ordinazioni	<i>Offers and orders</i>	100
8.4.1	Offerte	<i>Offers</i>	100
8.4.2	Ordini	<i>Orders</i>	101
8.4.3	Conferma d'ordine	<i>Order confirmation</i>	101
8.5	Prezzo dei prodotti	<i>Price of the products</i>	101
8.6	Spedizione e trasporto	<i>Shipping and transport</i>	102
8.7	Termini di consegna	<i>Terms of delivery</i>	102
8.8	Pagamenti	<i>Payments</i>	102
8.8.1	Reclami e/o contestazioni	<i>Claims and / or disputes</i>	102
8.8.2	Non conformità	<i>Non-compliance</i>	103
8.8.3	Restituzione del materiale	<i>Return of material</i>	103
8.8.4	Garanzia dei prodotti	<i>Product warranty</i>	103
8.9	Marchi e diritti di proprietà intellettuale	<i>Trademarks and intellectual property rights</i>	103
8.10	Controversie e risoluzione contrattuale	<i>Disputes and contract termination</i>	104
8.10.1	Clausola risolutiva art. 1755 C.C.	<i>Termination art. 1755 C.C. (Italian Civil Code)</i>	104
8.10.2	Clausola risolutiva art. 1761 C.C.	<i>Termination art. 1761 C.C. (Italian Civil Code)</i>	104

8.1 Scopo

Le presenti "Condizioni Generali di Vendita" (di seguito denominate "Condizioni di Vendita"), si applicano e regolano tutte le forniture di prodotti con marchio "TRAMEC" e/o commercializzate dalla stessa, e annullano qualsiasi clausola o termine pattuito dal Cliente, sia nella singola vendita che in documentazioni di provenienza dello stesso, che non sia state accettate da un preventivo consenso scritto da parte di "TRAMEC Srl".

8.1.1 Modifiche alle condizioni di vendita

"TRAMEC Srl" si riserva il diritto di modificare, aggiungere, cancellare qualsiasi punto delle presenti Condizioni di Vendita, che si riterranno applicate a tutti gli ordini successivi alla data di notifica al Cliente delle nuove Condizioni di Vendita.

8.2 Definizioni generali

Per una maggiore chiarezza nella lettura delle presenti Condizioni di Vendita, si definiscono i seguenti termini:

- "TRAMEC" : TRAMEC Srl, Via Bizzarri,6 – 70012 Caldera di Reno (BO) - ITALY
- "Prodotti": Tutti i beni prodotti, assemblati, commercializzati e/o venduti da TRAMEC Srl
- "Cliente" : Tutte le società legalmente costituite e/o entità giuridiche che acquistano beni, prodotti o servizi da TRAMEC Srl
- "Ordine" : Ogni proposta di acquisto di beni, prodotti o servizi inoltrata da un cliente a TRAMEC Srl e confermata per accettazione con "Conferma d'ordine" dalla stessa.
- "Marchi" : Tutti i marchi di proprietà di TRAMEC Srl di cui è proprietaria e/o licenziataria
- "Brevetti e Proprietà Intellettuale" : Qualsiasi diritto legato alla protezione del proprio Know-How, coperto da brevetti italiani e internazionali, per invenzioni, marchi, modelli, disegni e prodotti di cui TRAMEC Srl ne detiene ed è proprietaria dei diritti, siano essi registrati, che in fase di registrazione compresi qualsiasi altra forma prevista dalla leggi internazionali.

8.3 Riferimenti

Il presente documento è parte integrante del "LISTINO PREZZI TRAMEC", di cui copia è pubblicata sul sito aziendale www.tramec.it

8.4 Offerte e ordinazioni

8.4.1 Offerte

Su richiesta del Cliente, TRAMEC direttamente o attraverso la propria rete vendita, formulerà una proposta di acquisto per i propri prodotti indicati dal Cliente, formalizzandola per iscritto. L'offerta di vendita/proposta di acquisto non è da ritenersi impegnativa da parte del Cliente, e avrà validità 30(trenta) giorni. Allo scadere di tale termine, TRAMEC si riterrà svincolata da impegni e su richiesta del cliente riformulerà una nuova offerta/proposta.

Data la natura riservata del contenuto dell'offerta/proposta ricevuta il Cliente, si impegna a non divulgarne il contenuto.

8.1 Purpose

The present "General Conditions of Sale" (hereinafter referred to as "Conditions of Sale"), shall apply and shall govern all supplies of "TRAMEC" products with "TRAMEC" label and / or directly commercialized by "TRAMEC" , and cancel any clause or term agreed upon by the Customer which have not been accepted by prior consent in writing by "TRAMEC Srl".

8.1.1 Modification of the conditions of sale

"TRAMEC SRL" reserves the right to modify, add, delete any part of these "Conditions of Sale", which will be deemed to apply to all orders received after the date of Customer's notification.

8.2 General definitions

For a better understanding of these Conditions of Sale, we define the following terms:

- "TRAMEC" : TRAMEC Srl, Via Bizzarri,6 – 70012 Caldera di Reno (BO) - ITALY
- "Products": *All goods manufactured, assembled, commercialized and / or sold by TRAMEC Srl.*
- "Customers" : *All companies legally established and / or legal entities buying goods, products or services from TRAMEC SRL*
- "Orders" : *Each offer to purchase goods, products or services sent by the Customer to TRAMEC Srl and confirmed for acceptance with an "order confirmation" directly from TRAMEC Srl*
- "Trademarks" : *All trademarks owned or of which TRAMEC Srl is licensee.*
- "Patents and Intellectual Property" : *all rights related to the protection of their own Know - How, covered with Italian and international patents for inventions, trademarks, models, designs and products for which TRAMEC SRL holds and owns the rights, whether registered or under registration, including any other form prescribed by the International laws.*

8.3 References

This document is an integral part of the "PRICE LIST of TRAMEC", a copy of which is posted on the company website www.tramec.it

8.4 Offers and orders

8.4.1 Offers

On customer request, TRAMEC directly or through its own sales network, will submit a written proposal for the products required by the Customer. The offer shall not be binding for the Customer and will have a 30 (thirty) days validity. After this period the offer is void and upon Customer request TRAMEC will submit a new proposal. TRAMEC written offers are intended for the receipt and viewing of the Customer, and disclosure of the offer with competitors could render the offer null and void.

8.4.2 Ordini

Tutti gli ordini di acquisto dei prodotti TRAMEC, devono essere formalizzati per iscritto dal Cliente su propria carta intestata ed inviati tramite mail, fax o lettera direttamente ai riferimenti indicati nell'offerta/proposta ricevuta, avendo cura di aver indicato:

- Riferimento a n. offerta,
- codice prodotto,
- descrizione prodotto,
- quantità richiesta,
- prezzi e termini di consegna.

TRAMEC ha previsto la possibilità di accettare anche ordini a carattere di "URGENZA" previo accordi telefonici con il commerciale TRAMEC di riferimento, che devono essere formalizzati per iscritto dal Cliente, e che prevedono una consegna entro 7(sette) gg lavorativi, dalla data di accettazione dell'ordine stesso. A tali ordini verrà applicato una maggiorazione del 5%(cinquepercento), calcolata sul totale lordo dell'ordine, in aggiunta agli importi netti totali.

ATTENZIONE

Tutte le ordinazioni a carattere d'urgenza, una volta accettate non sono più modificabili.

8.4.3 Conferma d'ordine

La vendita si riterrà conclusa con l'invio della Conferma d'Ordine che TRAMEC inoltrerà al Cliente. Tale Conferma d'Ordine sarà inoltrata al cliente tramite mail o su richiesta tramite fax direttamente ai riferimenti indicati dal Cliente. La Conferma d'Ordine sarà conforme, all'ordine di acquisto del Cliente ricevuto da TRAMEC, sia nei termini che nelle condizioni indicate e concordate. Trascorsi 2(due) giorni lavorativi dall'invio della Conferma d'Ordine, TRAMEC riterrà confermato l'ordine da parte del Cliente ed ogni inesattezza eventualmente contenuta e non contestata in forma scritta da parte del Cliente e confermata sempre in forma scritta da TRAMEC (con nuova Conferma d'Ordine revisionata), evidenziata alla consegna dei prodotti al Cliente non sarà più contestabile o annullabile.

8.5 Prezzo dei prodotti

Tutti i prezzi dei prodotti indicati negli ordini di vendita, e nelle relative offerte, fanno riferimento al listino prezzi TRAMEC, in vigore al momento del loro inoltro al Cliente. Qualora non fosse presente il prodotto in ordine nel listino prezzi TRAMEC, avrà valore quanto concordato e confermato per iscritto nell'ordine stesso.

Eccetto quanto concordato per iscritto tra le parti, i prezzi indicati nell'ordine di vendita TRAMEC sono calcolati franco fabbrica,

al netto dell'IVA e degli sconti. Tali prezzi inoltre non includono eventuali costi di imballaggio, spedizione e trasporto dai locali di TRAMEC ai locali del cliente, che saranno sostenuti separatamente dal Cliente.

TRAMEC manterrà la proprietà dei Prodotti venduti al Cliente fino alla completa corresponsione del prezzo degli stessi. La presente clausola di riserva di proprietà, obbliga il Cliente a compiere tutti gli adempimenti previsti per legge, ove previsto, per rendere valida ed eseguibile nei confronti di tutti i terzi tale vincolo.

TRAMEC si riserva il diritto di modificare unilateralmente e senza preavviso, con effetto immediato i prezzi riportati nel proprio listino, nei casi in cui l'adeguamento sia dovuto a cambiamenti imprevisti di condizioni di mercato delle materie prime o dei tassi di cambio. Ogni modifica verrà comunque comunicata al Cliente ed applicata al successivo ordine ricevuto.

8.4.2 Orders

All purchase orders of "TRAMEC" products must be formalized in writing by the customer, on his own letterhead and sent via mail, fax or letter directly to the references mentioned in the offer, making sure to add :

- Offer reference number ,
- Product Code,
- Product Description,
- Required Quantity,
- Prices and Terms of Delivery.

"TRAMEC" option "URGENT" production must be offered by the sales department of "TRAMEC". To accept the urgent production offering , after telephone arrangement with the commercial reference "TRAMEC", Customer must state in writing, requesting URGENT option, and consider standard shipment of urgent orders to be 7 (seven) working days from the date of TRAMEC's acceptance of order. To urgent orders will be charged an additional 5% (five percent) calculated from the total value of the order.

ATTENTION!!!!

Urgent orders, once acknowledged by TRAMEC, are non-cancelable and may not be modified.

8.4.3 Order confirmation

TRAMEC will acknowledge the Customers Order via e mail or on request by fax to the address specified by the Customer. All Orders to be performed are subject to the Terms and Conditions Agreed to between the parties.

The Customer will have two (2) days to review the acknowledgment for errors or inaccuracies to notify TRAMEC for correction, after these two (2) days the Order will be considered acknowledged by the Customer and can no longer be contested or canceled.

8.5 Price of the products

All prices listed on the sales orders, and on offers, refer to the Price List of "TRAMEC" valid at time of their transmission to the Customer.

If the product is not mentioned on the Price List of "TRAMEC", its value will be the one agreed to between the parties in writing.

Unless differently agreed, the prices indicated on the sales order of TRAMEC will be calculated on ex-works basis, VAT and Discounts excluded.

These prices do not include any costs for packaging, shipping and transport from TRAMEC warehouse to the Customer premises, which will be paid separately by the Customer.

TRAMEC will retain the ownership of the Products sold to the customer until their complete payment. Because of this saving clause of ownership, the Customer is due to carry out all formalities required by law, and if necessary, to make such a constraint valid and enforceable against all third.

TRAMEC reserves the right to modify the prices of the price list, unilaterally and without notice, with immediate effect , if the adjustment is due to unexpected changes in market conditions, in raw materials or in exchange rates. Each modification will however be noted and indicated on the Order Acknowledgement and will apply to the next order.

8.6 Spedizione e trasporto

La spedizione viene effettuata tramite vettori nazionali ed internazionali, indicati dal Cliente o in mancanza di indicazioni scelti in autonomia da TRAMEC. La scelta del vettore viene effettuata sulla base di valutazione di convenienza e di garanzia del trasporto che il vettore stesso assicura/certifica. Tutto il materiale viaggia a spese e rischio del Cliente stesso, e si intende accettato dal Cliente all'atto di inizio del trasporto da parte del vettore. Eventuali danni occorsi al materiale durante il trasporto, non sono coperti da garanzia TRAMEC. Come indicato al punto 8.5 PREZZO DEI PRODOTTI, la merce viaggia sempre FRANCO FABBRICA.

8.7 Termini di consegna

I termini di consegna indicati nella Conferma d'Ordine, hanno carattere puramente indicativo e sono da ritenersi fissati salvi imprevisti ascrivibili a circostanze di forza maggiore e che siano fuori dal proprio controllo. A titolo esemplificativo e senza pretesa di esaustività si elenca quanto segue:

- a) Ritardi da parte del cliente a fornire dati tecnici o amministrativi necessari alla spedizione dei prodotti
- b) Difficoltà da parte di TRAMEC nell'acquisizione di materie prime necessarie alla produzione dei prodotti
- c) Scioperi parziali o totali, calamità naturali, difficoltà nel trasporto dei materiali, etc. e tutte le altre cause di forza maggiore
- d) Ritardi dovuti a terzi o allo spedizioniere

Il verificarsi di alcuni degli eventi elencati o di altra natura non elencati, non darà diritto al Cliente di esigere indennizzi di sorta o richiesta di risarcimento danni.

8.8 Pagamenti

TRAMEC a propria discrezione emetterà fattura, salvo accordi scritti tra le parti, all'atto della spedizione dei prodotti o in anticipo all'atto dell'accettazione dell'ordine del Cliente. Tutti i pagamenti sono previsti in EURO, eccetto per accordi commerciali che prevedano altra valuta. I pagamenti devono essere effettuati entro i termini stabiliti indicati nella Conferma d'Ordine, anche in presenza di reclami o contestazioni.

Ogni ritardo o mancato pagamento rispetto ai termini stabiliti darà diritto a TRAMEC di sospendere qualsiasi consegna di prodotti e/o ordine in corso e richiedere al Cliente il pagamento degli interessi bancari così come previsto dalle leggi vigenti nella misura del tasso stabilito da BCE + 7% (Settepercento).

Ogni reclamo e/o contestazione non potrà comunque in nessun modo giustificare la sospensione o il ritardato pagamento.

8.8.1 Reclami e/o contestazioni

Ogni tipologia di reclamo o contestazione dovrà essere formalizzato/a a TRAMEC in forma scritta direttamente all'indirizzo email customer.care@tramec.it o attraverso la sezione "Customer Care" presente sul proprio sito www.tramec.it. Eventuali reclami riferiti a vizi o difetti dei prodotti ricevuti dovranno essere segnalati a TRAMEC, sempre in forma scritta, entro 10 (dieci) gg dalla data di consegna.

Nel caso che tali vizi o difetti si evidenziassero, per la loro natura, successivamente alla data di consegna, essi dovranno essere segnalati, sempre in forma scritta, a TRAMEC immediatamente entro e non oltre 5 (cinque) gg dalla data di rilevazione, e comunque saranno ritenuti tali entro e non oltre l'anno di garanzia previsto per i prodotti TRAMEC.

Le spese di trasporto sono a carico del Cliente salvo diverso accordo tra le parti.

8.6 Shipping and transport

Shipments will be handled by national and international carriers specified by the Customer, if specific instructions are not included they will be at TRAMEC's discretion. Where shipment is made at TRAMEC's discretion, carrier choice will be made based on convenience and delivery terms assured by the carriers. Goods are sold to Customer and considered EX-WORKS (see 8.5.PRICE OF THE PRODUCTS), all transportation expense, loss, damages, or delays to be the risk and responsibility of the Customer and their carrier, and not subject to TRAMEC warranty written or implied.

8.7 Terms of delivery

Delivery terms mentioned in "TRAMEC" Order Confirmation are considered agreed upon and to be honored bearing unexpected events outside "TRAMEC" control, in example:

- a) The Customers delay of technical or administrative information necessary for the timely dispatch of the products.*
- b) Difficulties in the acquisition of raw materials required to manufacture TRAMEC products.*
- c) Total or partial labor strikes, natural disasters, transportation difficulties or other circumstances beyond TRAMEC control.*
- d) Delays due to third parties or to be inbound shipping company*

The occurrence of some of the events listed or other not listed, do not entitle the customer to claim any compensation or claim for damages.

8.8 Payments

Unless stated in writing and agreed upon, "TRAMEC" will invoice the Customer on Confirmation of Order for Customers with Prepaid Terms, or at time of shipment for the Customers with NET trade credit terms. Payments are to be made in EURO, except where specific commercial agreements are made in alternative currencies. Payments must be made within the stated NET terms offered at time of Order Confirmation, regardless of outside claims or conflicts.

Delay or missing payments outside of the agreed terms will afford TRAMEC the right to suspend any delivery of products, services, and any pending orders, as well as require the Customer to pay interest on past due invoices, as provided by law, to the extent determined by the ECB rate + 7% (seven percent)

NO claim or dispute can justify the suspension, delay, or non-payment of invoices due.

8.8.1 Claims and / or disputes

Each complaint or claim must be transmitted in writing to "TRAMEC", directly to the e mail address customer.care@tramec.it or through the website www.tramec.it, "Customer Care" section.

Any claim relating to defect must be reported in writing to "TRAMEC" within 10 (ten) days of the receipt of the product.

If a defect is noticed or occurs after the delivery date, it must be reported in writing to TRAMEC within 5 (five) days of the date the defect was detected, and always within the 1 (one) year warranty provided for TRAMEC products.

Transportation costs are borne by the Customer unless otherwise agreed to by TRAMEC and the Customer.

8.8.2 Non conformità

Eventuali non corrispondenze in tipologia del prodotto e/o quantità, rispetto a quanto indicato in Conferma d'Ordine, dovrà essere prontamente segnalata in forma scritta a TRAMEC o al proprio agente di riferimento entro e non oltre 5(cinque) gg dalla data di consegna del materiale. Dopo tale scadenza i prodotti consegnati si riterranno conformi all'ordine del Cliente e non potranno essere più contestati a TRAMEC. Le spese di trasporto sono a carico del Cliente salvo diverso accordo tra le parti.

8.8.3 Restituzione del materiale

Il materiale non può essere restituito a TRAMEC, senza preventiva autorizzazione scritta da parte della stessa. Eventuali materiali ricevuti senza che il Cliente abbia effettuato una segnalazione scritta così come previsto ai punti 8.8.1 e 8.8.2, ed autorizzata da TRAMEC, verranno respinti al mittente, con addebito delle spese di trasporto salvo diverso accordo tra le parti.

8.8.4 Garanzia dei prodotti

TRAMEC garantisce i propri prodotti, così come previsto dalle leggi vigenti, per un periodo di 1(uno) anno dalla data di fatturazione degli stessi. La garanzia opererà su tutti i prodotti TRAMEC, ove saranno rilevabili difetti di costruzione, montaggio o progettazione e comporterà per TRAMEC l'onere della sostituzione o riparazione delle parti difettose senza nessun altro aggravio e/o addebiti per danni diretti e/o indiretti di qualsiasi natura.

La garanzia decade nel caso siano state eseguite riparazioni, modifiche o manomissioni senza autorizzazione scritta da parte di TRAMEC e nel caso di mancanza della targhetta originale di fabbrica, presente su tutti i prodotti TRAMEC.

Un uso negligente o improprio e inosservanza delle prescrizioni sull'uso, manutenzione e conservazione dei prodotti, comporterà la decadenza immediata della garanzia. Il prodotto, coperto da garanzia, dovrà essere restituito a TRAMEC, così come indicato al punto 1.8.3, con spese di trasporto a carico del Cliente salvo diverso accordo tra le parti. La proprietà del prodotto o componente sostituito in garanzia, ove risultasse difettoso, sarà trasferita a TRAMEC dal Cliente.

Ogni diritto di garanzia non sarà applicabile, su quei prodotti a cui ancora non siano stati completamente corrisposti, alle condizioni e termini pattuiti, i relativi importi dovuti così come da fattura di riferimento. TRAMEC inoltre non garantisce nessuna garanzia circa alle conformità dei prodotti a norme e regolamenti di Paesi o Stati che non rientrano e appartengano alla Comunità Europea.

8.9 Marchi e diritti di proprietà intellettuale

TRAMEC è l'unica titolare dei propri Marchi, ed il Cliente si asterrà dall'utilizzo degli stessi senza preventiva autorizzazione, o registrare Marchi simili e/o confondibili con i medesimi. Ogni loro utilizzo comunque dovrà essere autorizzato in forma scritta da TRAMEC sia nelle modalità che nella forma, secondo indicazioni concordate con il titolare dei Marchi.

Tutti i diritti di Proprietà Intellettuale sono di totale ed esclusiva proprietà di TRAMEC e la loro comunicazione o utilizzo nell'ambito delle presenti "Condizioni Generali di Vendita" non produce nessun diritto o pretesa in capo al Cliente, che si obbliga a non compiere atti o richieste a contestarne la Titolarità e Proprietà.

8.8.2 Non-compliance

Any non-compliance with either product or its quantity found to be different from what is stated on Order Confirmation, must be reported in writing to TRAMEC or its Agent, no later than 5 (five) days from the delivery date of the material.

With no notification made after this time, the products will be considered complying with the order acknowledged to the Customer and shall no longer be contested to TRAMEC. Transportation costs are borne by the Customer unless otherwise agreed to by TRAMEC and the Customer.

8.8.3 Return of material

No goods or materials can be returned without "TRAMEC" prior written authorization. Materials received without authorization and written report from the Customer, as required in point 8.8.1 & 8.8.2, and fully authorized by "TRAMEC", will be returned to the sender at the senders expense for all transportation and customs fees, unless otherwise agreed to between the parties in writing.

8.8.4 Product warranty

"TRAMEC" guarantees its products, as provided by law, for a period of 1 (one) year from the date of invoice. This guarantee will be valid for all "TRAMEC" products, where construction, installation or design defects will be detected and will lead to "TRAMEC" the burden of replacement or repair of defective parts at its discretion without any other burden or responsibility or charges for any direct and / or indirect damages or expense.

"TRAMEC" warranty is void if repairs, changes or alterations are carried out on the product without the written consent of "TRAMEC", and only valid with the original nameplate which is found on all "TRAMEC" products.

The negligent or improper use as well as failure to observe regulations governing the utilization, maintenance and storage of products, will result in the immediate loss of this guarantee. The product, covered by the warranty, will have to be returned to "TRAMEC" free of charge, as indicated in point 9.3, with all transportation costs borne by the Customer unless otherwise agreed between the parties in writing. The product or component replaced under warranty, if it is defective, will belong to "TRAMEC".

The warranty will not be valid for products that are not paid in full, according to the conditions and terms agreed, and for the amounts due per relevant invoice.

"TRAMEC" provides no guarantee as for the conformity of their products with the standards and regulations of Countries or States not belonging to the European Community.

8.9 Trademarks and intellectual property rights

TRAMEC is the sole owner of its brands, and the Customer will refrain from the use of them without prior authorization, or register similar ones and/or brands that are easily confused with TRAMEC's brands. Every use of TRAMEC brands requires the authorization in writing by TRAMEC, both in terms and form, according to instructions agreed with the owner of these trademarks.

All Intellectual Property Rights are the complete and exclusive property of TRAMEC and their communication or use under these "Terms of Sale" does not product any right or claim to the Customer, which is obliged to refrain from acts or request to question the Possessory title and Property.

8.10 Controversie e risoluzione contrattuale

Tutte le controversie derivanti da o connesse alle presenti Condizioni di Vendita e/o ad ogni vendita, sono assoggettabili alla esclusiva giurisdizione del Foro competente di Bologna (ITALIA).

TRAMEC Srl è legalmente domiciliata presso la sua sede principale di Via Bizzarri,6 – 70012 Calderara di Reno(BO) – ITALY.

8.10.1 Clausola risolutiva art. 1755 C.C.

TRAMEC avrà facoltà di risolvere, ai sensi e per gli effetti dell'art. 1755 del Codice Civile Italiano, in qualsiasi momento con comunicazione scritta al Cliente, la singola vendita nel caso di inadempimento delle obbligazioni così come previsto ai punti 8.5 (Prezzo dei Prodotti), 8.8 (Pagamenti), 8.9 (Marchi e Diritti di Proprietà Intellettuale).

8.10.2 Clausola risolutiva art. 1761 C.C.

TRAMEC avrà diritto di sospendere, ai sensi e per gli effetti dell'art. 1761 del Codice Civile Italiano, in qualsiasi momento con comunicazione scritta al Cliente, tutte le obbligazioni in corso derivanti dalla vendita dei prodotti, nel caso in cui le condizioni patrimoniali del Cliente divenissero e/o risultassero tali da porre in serio dubbio la naturale acquisizione della contropartita prevista.

TRAMEC potrà valutare eventuali garanzie accessorie proposte dal Cliente, come assicurazione sulle obbligazioni in essere.

8.10 Disputes and contract termination

All disputes due or related to these "Terms of Sale" and / or any sale, are subject to the exclusive jurisdiction of the Competent Court of Bologna (ITALY).

TRAMEC SRL is legally domiciled at its headquarters in Via Bizzarri, 6-70012 Calderara di Reno (BO) - ITALY.

8.10.1 Termination art. 1755 C.C. (Italian Civil Code)

"TRAMEC" may terminate, pursuant to art. 1755 of the Italian Civil Code, at any time by written notice to the Customer, the single sale in the event of breach of the obligations as set out in paragraphs 8.5 (Product Price), 8.8 (Payments), 8.9 (Trademarks and Intellectual Property Rights).

8.10.2 Termination art. 1761 C.C. (Italian Civil Code)

"TRAMEC" will be entitled to suspend, pursuant to art. 1761 of the Italian Civil Code, at any time by written notice to the Customer, all current obligations arising from the sale of the products, in the event that the financial conditions of the Customer would become and/or result to call into serious doubt the natural acquisition of expected offset.

"TRAMEC" may consider any additional guarantees proposed by the Customer, such as insurance on outstanding obligations.

04/2018

Questo catalogo annulla e sostituisce ogni precedente edizione o revisione. Tutti i dati elencati sono indicativi e s'intendono senza impegno alcuno da parte nostra. Ci riserviamo il diritto di apportare modifiche senza preavviso.

This catalogue cancels and replaces any previous edition and revision. All listed data are approximate and it's understood that this entails no obligation on our part. We reserve the right to implement modifications without notice.

Mit der Ausgabe dieses Katalogs annullieren sich gleichzeitig alle bisherigen Katalogen. Sämtliche Daten sind Berechnete Werte die für den Verkäufer unverbindlich sind. Der Verkäufer behält sich das Recht vor, Änderungen, ohne eine vorhergehende Advisierung durchzuführen.

STAI PER ACQUISTARE IL PRIMO RIDUTTORE AL MONDO ANTIBATTERICO E BATTERIOSTATICO,
BREVETTO DEPOSITATO DA "TRAMEC Srl".

IL RIDUTTORE "GHA" NASCE DALLA INVENTIVA ITALIANA ED E' TOTALMENTE
"MADE IN ITALY"

YOU ARE ABOUT TO BUY THE FIRST ANTIBACTERIAL AND BACTERIOSTATIC GEARBOX IN THE WORLD,
PATENT PENDING "TRAMEC Srl".

"GHA" GEARBOX COMES FROM ITALIAN INVENTIVENESS AND IT'S TOTALLY
"MADE IN ITALY"

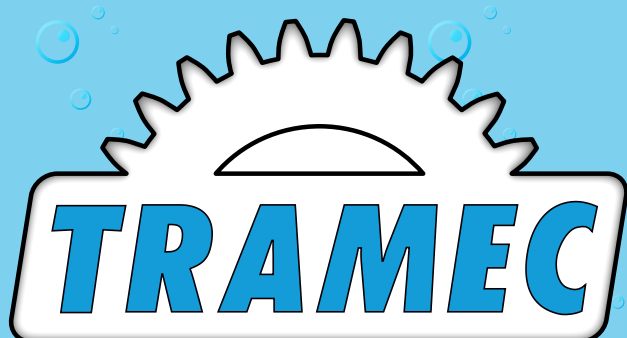

"PERFECTION IS A MASTERPIECE"

TRAMEC s.r.l.



Via Bizzarri, 6 Calderara di Reno 40012 Bologna - Italy

Tel. +39 051 728935 Fax. +39 051 728937

tramec@tramec.it - www.tramec.it