

CATALOGO GENERALE

LINEA ELICOIDALE

GENERAL CATALOGUE

HELICAL LINE





INDICE

CONTENTS

GENERALITÀ
DESIGNAZIONE, LEGENDA, RENDIMENTI
FATTORE DI SERVIZIO
FATTORE DI SERVIZIO PER APPARECCHI DI SOLLEVAMENTO
POTENZA TERMICA
IMPIANTI DI RAFFREDDAMENTO
SELEZIONE DEL RIDUTTORE
MODULO DI SELEZIONE

DATI TECNICI

Riduttori ad assi paralleli

PA singolo stadio

PB due stadi

PC tre stadi

PD quattro stadi

Riduttori ad assi ortogonali

RHB/RVB due stadi

RHC/RVC tre stadi

RHD/RVD quattro stadi

DIMENSIONI

Riduttori ad assi paralleli

PA singolo stadio

PB due stadi

PC tre stadi

PD quattro stadi

Riduttori ad assi ortogonali

RHB due stadi

RVB due stadi

RHC tre stadi

RVC tre stadi

RHD quattro stadi

RVD quattro stadi

ESECUZIONE GRAFICA

FORMA COSTRUTTIVA

ACCOPPIAMENTI PER MOTORI ELETTRICI

ESTREMITÀ D'ALBERO

FLANGE DI USCITA, FISSAGGIO PENDOLARE

DISPOSITIVO ANTIRETRO

CARICHI RADIALI, MOMENTI DI INERZIA

VELOCITÀ MASSIMA

PESI, QUANTITÀ DI OLIO

LUBRIFICAZIONE

STATO DI FORNITURA, STOCCAGGIO, INSTALLAZIONE

GENERAL INFORMATION	2-3
DESIGNATION, KEY TO SYMBOLS, EFFICIENCY	4-5
SERVICE FACTOR	6-8
SERVICE FACTOR FOR LIFTING MECHANISMS	10-11
THERMAL CAPACITY	12-13
COOLING SYSTEMS	14-15
SELECTION PROCEDURES	16-17
SELECTION DATA SHEET	18

TECHNICAL DATA

Helical units

PA single stage 20-21

PB double stage 22-23

PC triple stage 24-25

PD quadruple stage 26-27

Bevel-helical units

RHB/RVB double stage 28-29

RHC/RVC triple stage 30-31

RHD/RVD quadruple stage 32-33

DIMENSIONAL DATA

Helical units

PA single stage 34

PB double stage 35

PC triple stage 36

PD quadruple stage 37

Bevel-helical units

RHB double stage 38

RVB double stage 39

RHC triple stage 40

RVC triple stage 41

RHD quadruple stage 42

RVD quadruple stage 43

SHAFT ARRANGEMENTS 44-46

MOUNTING POSITIONS 46

ELECTRIC MOTORS COUPLINGS 47-52

SHAFT ENDING 53-56

OUTPUT FLANGES, SHAFT-MOUNTED APPLICATIONS 57

BACKSTOP DEVICES 58

OVERHUNG LOADS & MASS MOMENTS OF INERTIA 62-68

MAXIMUM SPEED 69-72

WEIGHTS AND LUBRICANT QUANTITIES 73

LUBRICATION 74

STATE OF SUPPLY, STORAGE, INSTALLATION 76-77



GENERALITÀ

I riduttori ad assi paralleli ed ortogonali **Reggiana Riduttori** della **serie standard** sono idonei per la maggior parte delle applicazioni industriali e sono disponibili nelle configurazioni ad 1,2,3,4 stadi di riduzione.

L'elevato rapporto potenza–peso e le dimensioni contenute, garantiscono installazioni perfette nelle condizioni più gravose.

Sono stati inoltre utilizzati nuovi criteri per migliorare in modo sostanziale il **livello di rumorosità**.

Per ottenere **prestazioni elevate**, si è curato il rendimento del ruotismo e la forma della superficie di scambio della carcassa per dissipare il calore prodotto.

Qualora richiesto dall'applicazione, i riduttori della serie standard, possono essere forniti con ventola/e di raffreddamento sull'albero veloce.

INGRANAGGI E ALBERI

Gli ingranaggi cilindrici, sono a profilo elicoidale rettificato dopo trattamento termico; gli ingranaggi conici, sono a profilo spiroidale Gleason. Entrambi i tipi vengono realizzati in acciaio da cementazione 20MnCr5 o 17NiCrMo6–4 UNI EN 10084, cementato e temprato.

Tutti gli ingranaggi sono stati progettati e verificati a durata e fatica secondo le normative ISO 6336 e ISO 10330 (25000 h).

Gli alberi lenti pieni sono costruiti in acciaio da bonifica 42CrMo4 UNI EN 10083–1 mentre gli alberi lenti cavi in Fe510B UNI EN 10025. Gli alberi veloci sono costruiti in acciaio da cementazione 20MnCr5 UNI EN 10084 cementato e temprato.

CARCASSA

Le carcasse dei riduttori sono generalmente realizzate in ghisa grigia EN–GJL–250 UNI EN 1561 fino alla grandezza 90 per la serie standard; per le grandezze superiori è prevista la realizzazione in acciaio Fe430B UNI EN 10025 elettrosaldato e disteso.

Su richiesta è comunque possibile produrre le carcasse in acciaio elettrosaldato e disteso per tutte le grandezze.

Tutte le carcasse sono costruite in due parti per facilitare il montaggio e la manutenzione del riduttore.

CONFIGURAZIONE ENTRATA

I riduttori ad assi paralleli ed ortogonali, possono essere configurati con albero di entrata pieno con linguetta secondo UNI6604:1969, con giunto elastico e flangia per motore IEC. A richiesta si possono realizzare flange per motori NEMA, esecuzioni compatte e speciali.

CONFIGURAZIONE USCITA

I riduttori ad assi paralleli ed ortogonali, possono essere altresì configurati con albero lento di uscita pieno con linguetta, cavo con linguetta secondo UNI6604:1969 e cavo con unità di bloccaggio.

Le istruzioni per la selezione dei riduttori contenute nel presente catalogo sono puramente indicative.

Si prega di contattare il Servizio Tecnico Reggiana Riduttori per una selezione ottimale dei riduttori e per le necessarie verifiche aggiuntive.

Reggiana Riduttori si riserva la facoltà di modificare, senza alcun preavviso, i dati tecnici o dimensionali contenuti nel presente catalogo, allo scopo di migliorare il prodotto.

E' vietata la riproduzione totale o parziale del presente catalogo, senza autorizzazione scritta da parte di Reggiana Riduttori s.r.l.



GENERAL INFORMATION

Reggiana Riduttori standard series of helical and bevel-helical units are suitable for most industrial applications and are available in single, double, triple, quadruple reduction stages.

The high power to weight ratio of all units, combined with low volume, enables perfect installation in the most critical situations.

New concepts have been used to improve the noise level in a consistent way.

To obtain higher performance, particular consideration has been given to efficiency and housing surface area to guarantee a convenient heat dissipation in most cases.

When necessary, standard series units can be supplied with cooling fan(s) fitted to high speed shaft.

GEARS AND SHAFTS

The cylindrical gears are with helical profile ground after heat treatment; the bevel gears are with Gleason spiral profile. Both of them are made of casehardened and tempered steel 20MnCr5 or 17NiCrMo6-4 UNI EN 100084.

All the gears have been designed and checked according to ISO 6336 and ISO 10330 standards (25000 h). The cylindrical low-speed shafts are made of quenched and tempered steel 42CrMo4 UNI EN 10083-1 while the hollow low-speed shafts are made of Fe510B UNI EN 10025. The high-speed shafts are made of casehardened and tempered steel 20MnCr5 UNI EN 10084.

GEAR CASING

The casings of the gear units are generally made of grey cast-iron EN-GJL-250 UNI EN 1561 up to size 90 for the standard series; larger sizes are made of electrically-welded and quenched steel Fe430B UNI EN 10025.

On requested, the casings can however be made of electrically-welded and quenched steel for all sizes.

All the casings are made in two parts to make gear unit fitting and maintenance easier.

INPUT CONFIGURATION

Helical and bevel-helical units can be configured with solid input shaft complete with key seats according to UNI6604:1969, with elastic coupling and flanges for IEC motor.

On requested, we can make flange for NEMA motor, and more compact and special solutions.

OUTPUT CONFIGURATION

Helical and bevel-helical units can be configured with solid output shaft complete with key seats or with hollow shaft with key seats according to UNI6604:1969 and hollow shaft with shrink disc.

The instructions for selecting the reduction gears in this catalogue are purely indicative.

Please contact the Reggiana Riduttori Technical Service for the best selection of the reduction gears and for the necessary additional checks.

Reggiana Riduttori reserves the right to change, without prior notice, the technical or dimensional data in this catalogue with the purpose of improving the product.

It is forbidden to reproduce this catalogue, totally or partially, without written authorisation from Reggiana Riduttori s.r.l.



DESIGNAZIONE

P	C	30	S	25	A	S	1
---	---	----	---	----	---	---	---

Forma costruttiva
1, 2, 3, 4, 5, 6, 7

Albero veloce

- S pieno con linguetta
- B pieno + flangia motore
- BC pieno + flangia motore + giunto

Esecuzione grafica

A, B, C, D, E, F, G, H, I, L, M, N

Rapporto di trasmissione i_N

Albero lento

- S pieno con linguetta
- C cavo con sede linguetta
- UB cavo con unità di bloccaggio

Grandezza

N°. stadi di riduzione

- A singolo stadio
- B due stadi
- C tre stadi
- D quattro stadi

Tipo

- P assi paralleli
- RH assi ortogonali orizzontali
- RV assi ortogonali verticali

LEGENDA

f_s	Fattore di servizio	
f_a	Fattore termico ambientale	
i_N	Rapporto di trasmissione nominale	
i_r	Rapporto di trasmissione esatto	
η	Rendimento	
n_1	Velocità angolare albero veloce	min^{-1}
$n_{1\text{max}}$	Velocità massima albero veloce	min^{-1}
n_2	Velocità angolare albero lento	min^{-1}
P_t	Potenza termica	kW
P_{tN}	Potenza termica nominale	kW
P_{N1}	Potenza nominale albero veloce	kW
P	Potenza assorbita	kW
t	Temperatura	$^{\circ}\text{C}$
T	Momento torcente	Nm
T_{N2}	Momento torcente nominale albero lento	Nm
F_{r1}	Carico radiale albero veloce	N
F_{r2}	Carico radiale albero lento	N
J_1	Momento d'inerzia albero veloce	kgm^2

RENDIMENTI

99%	Parallelo singolo stadio
98%	Parallelo due stadi
97%	Parallelo tre stadi
96%	Parallelo quattro stadi
97.5%	Ortagonale due stadi
96.5%	Ortagonale tre stadi
95.5%	Ortagonale quattro stadi



DESIGNATION

P	C	30	S	25	A	S	1
---	---	----	---	----	---	---	---

Mounting position

1, 2, 3, 4, 5, 6, 7

High speed shaft

S solid with key

B solid + motor flange

BC solid + motor flange + joint

Shaft arrangement

A, B, C, D, E, F, G, H, I, L, M, N

Transmission ratio i_N

Low-speed shaft

S solid with key

C hollow with key seat

UB hollow with shrink disc

Size

No. of stages

A single reduction

B double reduction

C triple reduction

D quadruple reduction

Type

P helical unit

RH horizontal bevel-helical unit

RV vertical bevel-helical unit

KEY TO SYMBOLS

f_s	Service factor	
f_a	Ambient correction factor	
i_N	Nominal transmission ratio	
i_r	Actual transmission ratio	
η	Efficiency	
n_1	High speed	min^{-1}
$n_{1\text{max}}$	Maximum input speed	min^{-1}
n_2	Low speed	min^{-1}
P_t	Thermal capacity	kW
P_{tN}	Nominal thermal capacity	kW
P_{N1}	Input nominal power	kW
P	Absorbed motor power	kW
t	Temperature	$^{\circ}\text{C}$
T	Torque	Nm
T_{N2}	Output nominal torque	Nm
F_{r1}	High-speed shaft overhung load	N
F_{r2}	Low-speed shaft overhung load	N
J_1	High-speed shaft mass moment of inertia	kgm^2

EFFICIENCY

99% Single reduction helical unit

98% Double reduction helical unit

97% Triple reduction helical unit

96% Quadruple reduction helical unit

97.5% Double reduction bevel-helical unit

96.5% Triple reduction bevel-helical unit

95.5% Quadruple reduction bevel-helical unit



FATTORE DI SERVIZIO

È un coefficiente moltiplicativo della potenza richiesta in entrata al riduttore, che tiene conto del tipo di servizio, della frequenza di avviamento, del numero di ore di funzionamento giornaliero, del tipo di motore impiegato e della durata richiesta. In base alla macchina su cui va applicato il riduttore, si individua dalla tabella della classificazione delle applicazioni il tipo di servizio (**U** uniforme, **M** moderato, **H** pesante) quindi si ricava il fattore dell'applicazione f_1 .

Applicazione	
Agitatori	
liquidi puri	U
con solidi in sospensione	M
liquidi densità variabile	M
Soffianti	
centrifughe	U
a lobi	M
a pale	U
Cabestani	M
Chiarificatori	U
Lavorazione argilla	
presse per mattoni	H
presse per mattonelle	H
impastatrici	M
Compressori	
centrifughi	U
a lobi	M
alternativi	
pluricilindrici	M
monocilindrici	H
Trasportatori carico uniforme	
a piastre	U
catene di montaggio	U
a nastro	U
a tazze	U
a catena	U
a coclea	U
Trasportatori carico pesante	
a piastre	M
catene di montaggio	M
a nastro	M
a tazze	M
a catena	M
alternativi	H
a coclea	M
vibratore	H
Argani	
sollevamenti principali	*
comandi ponte	*
comandi carrello	*
Frantoi	
per minerali	H
per pietre	H
per zucchero	H
Draghe	
trasportatori	M
comandi teste	H
pompe	M
comandi vagli	H
impilatori	M
Elevatori	
A tazze (carico uniforme)	U
A tazze (con sovraccarichi)	M
A scarico centrifugo	U
A scarico per gravità	U

Applicazione	
Ventilatori	
centrifughi	U
per torri di raffreddamento	
tiraggio indotto	M
tiraggio forzato	*
grandi per miniere	M
grandi industriali	M
leggeri (piccolo diametro)	U
Alimentatori	
a piastra	M
a nastro	M
a disco	U
alternativi	H
a vite	M
Industria alimentare	
affettatrici	M
torrefazione cereali	U
impastatrici	M
tritacarne	M
Generatori	U
Gru	
carico pesante	H
carico medio	M
Macchine lavatrici	M
Industria del legno	
scortecciatrici	M
convogliatori al forno	M
sega a catena	H
trasferimenti a catena	H
trasferimenti vie di corsa	H
convogliatori al forno	M
convogliatori tavole	H
trasportatori a nastro	U
trasportatori a catena	M
trasportatori gru di scarico	M
comandi gru di scarico	M
trasportatori rifiuti	M
Macchine utensili	
piegatrice a rulli	M
presse comando a ingranaggi	H
piattatrici	H
maschiatrici	H
altre	
comando principale	M
comando ausiliario	U
Industria del ferro	
cesoie	M
convogliatori piani	
non reversibili	M
reversibili	*
macchine avvolgimento filo	M
Mescolatori	
betoniere	M
A densità costante	U
A densità variabile	M

Applicazione	
Stazioni di pompaggio petrolio	*
Cartiere	
agitatori	M
scortecciatrici idrauliche	M
scortecciatrici meccaniche	H
scortecciatrici a tamburo	H
candeggiatrice	U
calandre	M
trasportatori	U
tagliatrici piane	H
cilindri	M
essiccatori	M
tendifeltro	M
battifeltro	H
Jordan	M
Presse per stampa	U
Pompe	
centrifughe	U
dosatrici	M
alternative	
semp. Effetto > 2 cilindri	M
semp. Effetto < 3 cilindri	*
doppio effetto > 1 cilindro	M
doppio effetto 1 cilindro	*
rotative, a ingranaggi, a lobi	U
Gomma e materie plastiche	
rompitori	H
raffinatori	M
calandre	M
estrusori pellicole	U
estrusori lamine	U
estrusori in genere	U
Molazze per sabbia	M
Depurazione acque luride	
grigliatrici	U
alimentatori chimici	U
coclee disidratanti	M
rompiscorie	M
mescolatori	M
ispessitori	M
filtri sottovuoto	M
Vagli	
lavaggi ad aria	M
rotativi, a pietre o a ciottoli	U
prese d'acqua	M
Industria dello zucchero	
tagliatrici	M
frantoi	M
trasportatori polpe	M
Industria tessile	
calandre	M
carde	M
essiccatoi	M
tingitrici	M
macchine per maglieria	*
telai per tessitura	M
mangani	M
insaponatrici	M
filatoi	M
lavatrici	M

* contattarci



SERVICE FACTOR

It is a multiplicative coefficient of the required power in input from the reduction gear and takes into account the type of duty, start-up frequency, the number of hours of operation per day, the type of motorisation and the duration requested. According to the machine the reduction is going to be mounted on, the type of service (**U** uniform, **M** moderate or **H** heavy) can be found in the application classification table. Then you can find the application factor f_1 .

Driven machine	Type of load
Agitators	
pure liquids	U
liquids and solids	M
liquids-variable density	M
Blowers	
centrifugal	U
lobe	M
vane	U
Car pullers	M
Clarifiers	U
Clay working machinery	
brick press	H
briquette machine	H
clay working machinery	M
Compressors	
centrifugal	U
lobe	M
reciprocating	
multi-cylinder	M
single-cylinder	H
Conveyors-uniformly fed	
apron	U
assembly	U
belt	U
bucket	U
chain	U
screw	U
Conveyors-heavy duty	
apron	M
assembly	M
belt	M
bucket	M
chain	M
reciprocating	H
screw	M
shaker	H
Cranes	
main hoist	*
bridge travel	*
trolley travel	*
Crushers	
ore	H
stone	H
sugar	H
Dredges	
conveyors	M
cutter head drives	H
pumps	M
screen drive	H
stackers	M
Elevators	
bucket-uniform load	U
bucket-heavy load	M
centrifugal discharge	U
gravity discharge	U

Driven machine	Type of load
Fans	
centrifugal	U
cooling towers	
induced draft	M
forced draft	*
large, mining	M
large, industrial	M
light, small diameter	U
Feeders	
apron	M
belt	M
disc	U
reciprocating	H
screw	M
Food industry	
slicers	M
cereal cooker	U
dough mixer	M
meat grinders	M
Generators	U
Hoists	
heavy duty	H
medium duty	M
Laundry tumblers	M
Lumber industry	
de-barkers	M
burner conveyor	M
chain saw, drag saw	H
chain transfer	H
craneway transfer	H
conveyor	M
slab conveyor	H
conveyor-belt	U
conveyor-chain	M
tipple hoist conveyor	M
tipple hoist drive	M
waste conveyor	M
Machine tools	
bending roll	M
punch press-gear driven	H
plate planers	H
tapping machine	H
other machine tools	
main drives	M
auxiliary drives	U
Metal mills	
slitters	M
table conveyors	
non-reversing	M
reversing	*
wire winding machine	M
Mixers	
concrete mixer	M
constant density	U
variable density	M

Driven machine	Type of load
Oil well pumping	*
Paper mills	
agitators	M
de-barkers-hydraulic	M
de-barkers-mechanical	H
barking drum	H
bleacher	U
calenders	M
conveyors	U
cutters-plates	H
cylinders	M
dryers	M
felt stretcher	M
felt wipper	H
jordans	M
Printing press	U
Pumps	
centrifugal	U
proportioning	M
reciprocating	
single acting >2 cylinders	M
single acting <3 cylinders	*
double acting >1 cylinder	M
double acting 1 cylinder	*
rotary, gear, lobe type	U
Rubber and plastics	
crackers	H
refiners	M
rubber calenders	M
films extruders	U
sheets extruders	U
extruders	U
Sand muller	M
Sewage disposal equip.	
bar screeners	U
chemical feeders	U
dewatering screws	M
scum breakers	M
mixers	M
thickeners	M
vacuum filter	M
Screens	
air washing	M
rotary-stone or gravel	U
travelling water intake	M
Sugar industry	
cane and beet knives	M
crushers	M
pulp conveyors	M
Textile industry	
calenders	M
cards	M
dryers	M
dyeing machinery	M
knitting machines	*
looms	M
mangles	M
soapers	M
spinners	M
washers	M

* refer to us



f_1		U			M			H		
		Ore di funzionamento giornaliere – <i>Hours of operation per day</i>								
		< 1	1 ÷ 8	8 ÷ 24	< 1	1 ÷ 8	8 ÷ 24	< 1	1 ÷ 8	8 ÷ 24
N° avviamenti/ora <i>No. of start-ups/hour</i>	< 6	0.7	0.9	1.1	0.9	1.1	1.3	1	1.3	1.7
	6 ÷ 60	0.9	1.2	1.4	1.1	1.4	1.6	1.4	1.7	2
	> 60	1.2	1.5	1.7	1.4	1.7	2	1.7	2.1	2.5

Dalle altre tabelle si ricavano i fattori:

From the other tables you can get the factors:

- f_2 fattore della macchina motrice
- f_3 fattore di durata

- f_2 *mechanical service factor*
- f_3 *duration factor*

f_2		
Motore elettrico, motore idraulico, turbina	<i>Electric motor, hydraulic motor, steam turbine</i>	1
Motore a scoppio pluricilindrico	<i>Multi-cylinder internal combustion engine</i>	1.25
Motore a scoppio monocilindrico	<i>Single-cylinder internal combustion engine</i>	1.5

f_3				
Durata richiesta / <i>Duration required</i>				
6300 h	12500 h	25000 h	50000 h	100000 h
0.8	0.9	1	1.2	1.3

Infine si calcola il fattore di servizio come:

You can calculate the service factor as:

$$f_s = f_1 \cdot f_2 \cdot f_3$$



A series of horizontal lines spanning the width of the page, providing a template for writing or drawing.



FATTORE DI SERVIZIO PER APPARECCHI DI SOLLEVAMENTO

In tabella sono riportati i fattori di servizio, da adottare per la sezione dei riduttori linea elicoidale, in funzione della classe di carico, della classe di utilizzo e del gruppo del meccanismo. Il fattore di servizio deriva dalla combinazione di una serie di condizioni legate a durata, sovraccarichi, frequenza degli avviamenti, tipo di motorizzazione, velocità e affidabilità, nel rispetto delle condizioni relative alle classi dei meccanismi di sollevamento riportate nelle norme FEM 1.001/III e ISO 430 1/1.

fs		CLASSE DI UTILIZZO									
CLASSE DI CARICO		USO NON REGOLARE	USO NON REGOLARE	USO NON REGOLARE	USO NON REGOLARE	USO REGOLARE	USO REGOLARE	USO REGOLARE	USO INTENSIVO	USO INTENSIVO	USO INTENSIVO
		T0	T1	T2	T3	T4	T5	T6	T7	T8	T9
		≤ 200 h	> 200 h ≤ 400 h	> 400 h ≤ 800 h	> 800 h ≤ 1600 h	> 1600 h ≤ 3200 h	> 3200 h ≤ 6300 h	> 6300 h ≤ 12500 h	> 12500 h ≤ 25000 h	> 25000 h ≤ 50000 h	> 50000 h
L1	fs ≥	0.8	0.8	0.8	0.8	0.8	0.8	0.8	0.9	1.1	1.3
Leggero	Classe	M1	M1	M1	M2	M3	M4	M5	M6	M7	M8
km ≤ 0.125 k ≤ 0.5	Avv./h Servizio kz ≥	(1 Dm) 90 15% 0.83	(1 Dm) 90 15% 0.83	(1 Dm) 90 15% 0.83	(1 Cm) 120 20% 0.83	(1 Bm) 150 25% 0.83	(1 Am) 180 30% 0.83	(2 m) 240 40% 0.83	(3 m) 300 50% 0.74	(4 m) 360 60% 0.60	(5 m) ≥ 360 60% 0.51
L2	fs ≥	0.8	0.8	0.8	0.8	0.8	0.8	0.9	1.1	1.3	1.5
Moderato	Classe	M1	M1	M2	M3	M4	M5	M6	M7	M8	M8
0.125 < km ≤ 0.25 0.5 < k ≤ 0.63	Avv./h Servizio kz ≥	(1 Dm) 90 15% 0.83	(1 Dm) 90 15% 0.83	(1 Cm) 120 20% 0.83	(1 Bm) 150 25% 0.83	(1 Am) 180 30% 0.83	(2 m) 240 40% 0.83	(3 m) 300 50% 0.74	(4 m) 360 60% 0.60	(5 m) ≥ 360 60% 0.51	(5 m) ≥ 360 60% 0.44
L3	fs ≥	0.8	0.8	0.8	0.9	0.9	1	1.2	1.4	1.8	2.2
Pesante	Classe	M1	M2	M3	M4	M5	M6	M7	M8	M8	M8
0.25 < km ≤ 0.5 0.63 < k ≤ 0.8	Avv./h Servizio kz ≥	(1 Dm) 90 15% 0.83	(1 Cm) 120 20% 0.83	(1 Bm) 150 25% 0.83	(1 Am) 180 30% 0.74	(2 m) 240 40% 0.74	(3 m) 300 50% 0.67	(4 m) 360 60% 0.56	(5 m) ≥ 360 60% 0.48	(5 m) ≥ 360 60% 0.44	(5 m) ≥ 360 60% 0.37
L4	fs ≥	0.8	0.8	0.9	0.9	1	1.2	1.4	1.8	2.2	2.5
Molto pesante	Classe	M2	M3	M4	M5	M6	M7	M8	M8	M8	M8
0.5 < km ≤ 1 0.8 < k ≤ 1	Avv./h Servizio kz ≥	(1 Cm) 120 20% 0.83	(1 Bm) 150 25% 0.83	(1 Am) 180 30% 0.74	(2 m) 240 40% 0.74	(3 m) 300 50% 0.67	(4 m) 360 60% 0.56	(5 m) ≥ 360 60% 0.48	(5 m) ≥ 360 60% 0.44	(5 m) ≥ 360 60% 0.37	(5 m) ≥ 360 60% 0.33

$$k = (k_m)^{1/3} = \left\{ \sum_{i=1..n} [(P_i/P_{max})^3 \cdot (t_i/T)] \right\}^{1/3}$$

k: fattore di spettro equivalente medio

k_m: fattore di spettro

t_i: durata media di ciascun livello di carico

T: durata totale di utilizzo

P_i: ampiezza di ciascun livello di carico

P_{max}: ampiezza del massimo livello di carico

L1: meccanismi soggetti solitamente a bassi carichi e raramente al massimo carico

L2: meccanismi soggetti solitamente a carichi moderati e raramente al massimo carico

L3: meccanismi soggetti normalmente a carichi pesanti e frequentemente al massimo carico

L4: meccanismi soggetti regolarmente al massimo carico

Le durate sono puramente teoriche, non possono essere prese come garanzia e si possono ricavare dall'utilizzazione media giornaliera, dal numero di giorni lavorativi e dagli anni di funzionamento previsti.

I fattori di servizio **fs** indicati sono validi solo per apparecchi di sollevamento e tengono conto del numero di avviamenti massimi indicato e di una coppia massima sul riduttore durante gli intervalli di avviamento e frenatura T_{2max}, limitata dal fattore di picco k_z.

Nel caso in cui F_{r2} ≤ (F_{r2max}/2) si può considerare: per L3-T8, L4-T7 fs ≥ 1.5; per L3-T9, L4-T8 fs ≥ 1.8; per L4-T9 fs ≥ 2.



SERVICE FACTOR FOR LIFTING MECHANISMS

The table shows the service factors to be used during the selection of the helical line, such factors are related to the load spectrum class, class of utilization and of the mechanism group.

The service factor stems from the combination of a series of conditions related to duration, overloads, start-up frequencies, type of motorisation, speed and reliability, in accordance with the conditions relating to the classes of lifting mechanisms indicated in the FEM 1.001/III and ISO 430 1/1 standards.

fs		CLASS OF UTILIZATION									
		IRREGULAR USE	IRREGULAR USE	IRREGULAR USE	IRREGULAR USE	REGULAR USE	REGULAR USE	REGULAR USE	INTENSIVE USE	INTENSIVE USE	INTENSIVE USE
		T0	T1	T2	T3	T4	T5	T6	T7	T8	T9
LOAD SPECTRUM CLASS		≤ 200 h	> 200 h ≤ 400 h	> 400 h ≤ 800 h	> 800 h ≤ 1600 h	> 1600 h ≤ 3200 h	> 3200 h ≤ 6300 h	> 6300 h ≤ 12500 h	> 12500 h ≤ 25000 h	> 25000 h ≤ 50000 h	> 50000 h
	L1	fs ≥	0.8	0.8	0.8	0.8	0.8	0.8	0.8	0.9	1.1
Light	Class	M1	M1	M1	M2	M3	M4	M5	M6	M7	M8
km ≤ 0.125 k ≤ 0.5	Start/hr Service kz ≥	(1 Dm) 90 15% 0.83	(1 Dm) 90 15% 0.83	(1 Dm) 90 15% 0.83	(1 Cm) 120 20% 0.83	(1 Bm) 150 25% 0.83	(1 Am) 180 30% 0.83	(2 m) 240 40% 0.83	(3 m) 300 50% 0.74	(4 m) 360 60% 0.60	(5 m) ≥ 360 60% 0.51
L2	fs ≥	0.8	0.8	0.8	0.8	0.8	0.8	0.9	1.1	1.3	1.5
Moderate	Class	M1	M1	M2	M3	M4	M5	M6	M7	M8	M8
0.125 < km ≤ 0.25 0.5 < k ≤ 0.63	Start/hr Service kz ≥	(1 Dm) 90 15% 0.83	(1 Dm) 90 15% 0.83	(1 Cm) 120 20% 0.83	(1 Bm) 150 25% 0.83	(1 Am) 180 30% 0.83	(2 m) 240 40% 0.83	(3 m) 300 50% 0.74	(4 m) 360 60% 0.60	(5 m) ≥ 360 60% 0.51	(5 m) ≥ 360 60% 0.44
L3	fs ≥	0.8	0.8	0.8	0.9	0.9	1	1.2	1.4	1.8	2.2
Heavy	Class	M1	M2	M3	M4	M5	M6	M7	M8	M8	M8
0.25 < km ≤ 0.5 0.63 < k ≤ 0.8	Start/hr Service kz ≥	(1 Dm) 90 15% 0.83	(1 Cm) 120 20% 0.83	(1 Bm) 150 25% 0.83	(1 Am) 180 30% 0.74	(2 m) 240 40% 0.74	(3 m) 300 50% 0.67	(4 m) 360 60% 0.56	(5 m) ≥ 360 60% 0.48	(5 m) ≥ 360 60% 0.44	(5 m) ≥ 360 60% 0.37
L4	fs ≥	0.8	0.8	0.9	0.9	1	1.2	1.4	1.8	2.2	2.5
Very heavy	Class	M2	M3	M4	M5	M6	M7	M8	M8	M8	M8
0.5 < km ≤ 1 0.8 < k ≤ 1	Start/hr Service kz ≥	(1 Cm) 120 20% 0.83	(1 Bm) 150 25% 0.83	(1 Am) 180 30% 0.74	(2 m) 240 40% 0.74	(3 m) 300 50% 0.67	(4 m) 360 60% 0.56	(5 m) ≥ 360 60% 0.48	(5 m) ≥ 360 60% 0.44	(5 m) ≥ 360 60% 0.37	(5 m) ≥ 360 60% 0.33

$$k = (k_m)^{1/3} = \left\{ \sum_{i=1 \dots n} [(P_i/P_{max})^3 \cdot (t_i/T)] \right\}^{1/3}$$

k : average equivalent spectrum factor

k_m : spectrum factor

t_i : average duration of each load level

T : total use duration

P_i : amplitude of each load level

P_{max} : amplitude of maximum load level

L1: mechanisms usually subject to low loads and rarely to maximum load

L2: mechanisms usually subject to moderate loads and rarely to maximum load

L3: mechanisms normally subject to heavy loads and frequently to maximum load

L4: mechanisms regularly subject to maximum load.

The durations are purely theoretical, they cannot be guaranteed and can be obtained from daily average use, from the number of working days and from the expected years of operation.

The indicated fs service factors are only valid for lifting equipment and take into account the maximum indicated number of starts and a max torque on the gear unit during T_{2max} , start and braking intervals, limited by the k_z peak factor.

In the case in which $F_{r2} \leq (F_{r2max}/2)$ it can be considered: for L3-T8, L4-T7 $fs \geq 1.5$; for L3-T9, L4-T8 $fs \geq 1.8$; for L4-T9 $fs \geq 2$.



POTENZA TERMICA

Vengono riportati nelle tabelle successive i valori delle potenze termiche nominali nelle condizioni di raffreddamento naturale e con ventola, alla temperatura ambiente di 20°C. Per condizioni ove venga richiesta una elevata dissipazione di calore unitamente ad una grande affidabilità, si consiglia l'utilizzo di uno scambiatore di calore acqua-olio od aria-olio.

La verifica della potenza termica non è di norma necessaria se il periodo di funzionamento continuo è inferiore a 3 ore ed è seguito da un tempo di inattività sufficiente a ripristinare nel riduttore la temperatura ambiente.

Potenza termica nominale P_{tN} (kW) – Raffreddamento naturale

	10	20	30	40	50	60	70	80	90	100	110
PA	55	72	93	115	148	180	212	271	338	408	505
PB	30	40	52	66	86	106	125	163	206	252	316
PC	23	31	40	51	66	82	98	127	162	199	252
PD	18	24	32	40	52	65	78	102	130	161	205
RHB/RVB	30	40	52	66	86	106	125	163	206	252	316
RHC/RVC	23	31	40	51	66	82	98	127	162	199	252
RHD/RVD	18	24	32	40	52	65	78	102	130	161	205

Potenza termica nominale P_{tN} (kW) – Raffreddamento con ventola

	10	20	30	40	50	60	70	80	90	100	110
PA (*)	80	104	135	167	215	261	307	393	490	592	732
PB (**)	44	58	75	96	125	154	181	236	299	365	458
PC (**)	33	45	58	74	96	119	142	184	235	289	365
RHB/RVB	45	60	78	99	129	159	188	245	309	378	474
RHC/RVC	35	47	60	77	99	123	147	191	243	299	378
RHD/RVD	27	36	48	60	78	98	117	153	195	242	308

(*) disponibile solo per esecuzione grafica A e B

(**) con ventola doppia moltiplicare per 1.2

Per temperature differenti, il valore della Potenza termica P_t si ottiene moltiplicando la potenza termica nominale P_{tN} relativa al raffreddamento prescelto per il fattore termico ambientale f_a ricavabile dalla tabella in basso.

$$P_t = P_{tN} \times f_a$$

Fattore termico ambientale f_a

Temperatura ambiente	Raffreddamento naturale	Raffreddamento con ventola
10 °C	1.14	1.04
20 °C	1	1
30 °C	0.86	0.94
40 °C	0.72	0.89
50 °C	0.56	0.83



THERMAL CAPACITY

The tables below show the values of the thermal capacities under different cooling conditions, viz: natural cooling, fan cooling. Values apply to an ambient temperature of 20°C.

Whenever a high heat dissipation level is required together with high operational reliability, it is recommended to consider the application of a water-oil or air-oil heat exchanger.

Checking the thermal capacity is not normally necessary if the period of continuous operation is less than 3 hours and is followed by a period of inactivity long enough to restore room temperature in the gear unit.

Nominal thermal capacity P_{tN} (kW) – Natural cooling

	10	20	30	40	50	60	70	80	90	100	110
PA	55	72	93	115	148	180	212	271	338	408	505
PB	30	40	52	66	86	106	125	163	206	252	316
PC	23	31	40	51	66	82	98	127	162	199	252
PD	18	24	32	40	52	65	78	102	130	161	205
RHB/RVB	30	40	52	66	86	106	125	163	206	252	316
RHC/RVC	23	31	40	51	66	82	98	127	162	199	252
RHD/RVD	18	24	32	40	52	65	78	102	130	161	205

Nominal thermal capacity P_{tN} (kW) – Fan cooling

	10	20	30	40	50	60	70	80	90	100	110
PA (*)	80	104	135	167	215	261	307	393	490	592	732
PB (**)	44	58	75	96	125	154	181	236	299	365	458
PC (**)	33	45	58	74	96	119	142	184	235	289	365
RHB/RVB	45	60	78	99	129	159	188	245	309	378	474
RHC/RVC	35	47	60	77	99	123	147	191	243	299	378
RHD/RVD	27	36	48	60	78	98	117	153	195	242	308

(*) only available for shaft arrangements A and B

(**) with 2 fans, multiply by 1.2

For different temperatures, the thermal capacity P_t can be obtained by multiplying the nominal thermal capacity P_{tN} for the selected type of cooling, by the ambient thermal factor f_a shown in the next table.

$$P_t = P_{tN} \times f_a$$

Ambient thermal factor f_a

Ambient temperature	Natural cooling	Fan cooling
10 °C	1.14	1.04
20 °C	1	1
30 °C	0.86	0.94
40 °C	0.72	0.89
50 °C	0.56	0.83



IMPIANTI DI RAFFREDDAMENTO

Gli impianti di raffreddamento vengono forniti quando il raffreddamento naturale del riduttore e/o il raffreddamento artificiale con ventola non sono più sufficienti per soddisfare la verifica della potenza termica.

Gli impianti di raffreddamento possono essere suddivisi in tre tipologie principali : con scambiatore di calore acqua-olio (RF), con scambiatore di calore aria-olio (RFA) e con lubrificazione forzata (RFL).

Gli impianti con lubrificazione forzata vengono utilizzati in condizioni particolari quali:

- Quando la lubrificazione a sbattimento non è possibile in particolari posizioni di montaggio.
- Quando è presente alta velocità in ingresso contestualmente ad alte velocità periferiche sugli ingranaggi.

Ogni categoria è suddivisa in più grandezze, con potenze di scambio e portate olio diversificate per ogni specifica esigenza.

Gli impianti di raffreddamento vengono forniti come unità complete annesse al riduttore e comprensive dei tubi del circuito di raffreddamento ma senza gli attacchi elettrici. Sono inoltre fornibili anche impianti con tutti i particolari assemblati su di un telaio per l'installazione separata, ma in questo caso i collegamenti mediante tubi flessibili (tipo SAE 100 R1 con lunghezza massima ammessa di 4m) tra riduttore e unità di raffreddamento sono a cura del cliente. Tutti gli impianti vengono comunque forniti con le parti metalliche protette da verniciatura (fondo epossidico e smalto sintetico RAL9005) per garantirne una lunga durata agli agenti atmosferici.

Sono inoltre disponibili a richiesta accessori per soddisfare ogni esigenza di funzionalità e sicurezza (pressostati, termostati, ecc.).

Di seguito viene mostrata una tabella che ha lo scopo di riassume i principali impianti di raffreddamento fornibili, suddivisi per la loro capacità di scambio:

Tipo RF	Potenza termica [kW]	Tipo RFA	Potenza termica [kW]
RF1	< 3.5	CSU 04	< 4
RF2	3.5 ÷ 5.8	CSU 10	4 ÷ 10
RF3	5.8 ÷ 10.2	CSU 20	10 ÷ 20
RF4	10.2 ÷ 14		
RF5	14 ÷ 20.9		



COOLING SYSTEMS

Cooling systems are provided when the natural and/or fan cooling of the gear reducer are not sufficient for the thermal power verification.

They can be divided in three types:

With water-oil heat exchanger (RF), with air-oil heat exchanger (RFA), with forced lubrication (RFL).

Forced lubrication systems are utilized when:

- The splash lubrication is not possible because of the mounting position;
- High input speed is combined with high peripheral speed of the gears.

Each category is divided in different sizes, thermal powers and oil flows.

Cooling systems are supplied as a complete unit with the gear reducer, with cooling system pipes but without electrical contacts. Reggiana Riduttori can also supply systems assembled on a frame for separated installation, but, in this case, the connections with flexible pipes (SAE 100 R1, maximum length 4m) between helical and cooling unit are the responsibility of the customer.

All systems are supplied with metal parts protected from painting (epoxy primer and RAL9005 synthetic enamel) guaranteeing a long life.

On request, accessories are available in order to satisfy all functionality and safety requirement (pressure switches, thermostats, etc.).

The following table summarizes the main cooling systems according to the heat exchange capacity.

RF Type	Thermal Power [kW]	RFA Type	Thermal Power [kW]
RF1	< 3.5	CSU 04	< 4
RF2	3.5 ÷ 5.8	CSU 10	4 ÷ 10
RF3	5.8 ÷ 10.2	CSU 20	10 ÷ 20
RF4	10.2 ÷ 14		
RF5	14 ÷ 20.9		



SELEZIONE DEL RIDUTTORE

Dati richiesti:

- Potenza assorbita P (kW)
- Velocità in entrata n_1 (min^{-1})
- Rapporto di trasmissione i_N
- Fattore di servizio f_s
- Temperatura ambiente t ($^{\circ}\text{C}$)

Calcolare la potenza nominale richiesta in ingresso al riduttore come:

$$P_{N1} = P \cdot f_s$$

quindi individuare dalle tabelle dei dati tecnici il riduttore più idoneo, ovvero un riduttore con rapporto nominale i_N che abbia una P_{N1} maggiore di quella richiesta in corrispondenza del numero di giri n_1 .

Calcolare la potenza termica nominale come:

$$P_{tN} = P_t \cdot f_a$$

dove P_t è la potenza termica del riduttore selezionato ed f_a è il fattore termico ambientale determinato in base alla temperatura ambiente t .

Verificare che la potenza termica nominale P_{tN} sia maggiore della potenza assorbita P . In caso contrario passare al raffreddamento con ventola e calcolare nuovamente P_{tN} verificando che risulti maggiore della potenza assorbita. Nel caso in cui P_{tN} fosse ancora inferiore a P , selezionare un riduttore di grandezza superiore o contattarci per il dimensionamento di un sistema di raffreddamento con scambiatore.

Esempio

Riduttore ad assi paralleli

- $P = 220$ kW
- $n_1 = 1500$ min^{-1}
- $i_N = 5.6$
- $f_s = 1.75$
- $t = 30^{\circ}\text{C}$

$$P_{N1} = P \cdot f_s = 220 \times 1.75 = 385 \text{ kW}$$

Il riduttore PA 60 $i_N = 5.6$ fornisce 421 kW a 1500 min^{-1} e sarebbe meccanicamente idoneo per l'applicazione. La potenza termica con raffreddamento naturale risulta:

$$P_t = P_{tN} \cdot f_a = 180 \times 0.86 = 155 \text{ kW}$$

Essendo tale valore inferiore alla potenza $P = 220$ kW, il riduttore dovrà quindi essere fornito di un raffreddamento artificiale.

Adottando il raffreddamento con 1 ventola si ottiene:

$$P_t = P_{tN} \cdot f_a = 261 \times 0.94 = 245 \text{ kW}$$

Poiché $P = 220$ kW è inferiore a $P_t = 245$ kW, il riduttore con 1 ventola è idoneo all'applicazione.

Qualora il raffreddamento con ventola/e fosse insufficiente, l'utilizzo di uno scambiatore olio-acqua o olio-aria può risolvere brillantemente ed anche economicamente (per grandezze medie e medio grandi) il problema termico, garantendo la massima affidabilità.



SELECTION PROCEDURES

Data required:

- Absorbed motor power P (kW)
- Input speed n_1 (min^{-1})
- Gearbox ratio i_N
- Service factor f_s
- Ambient temperature t ($^{\circ}\text{C}$)

Calculate the required input nominal power as:

$$P_{N1} = P \cdot f_s$$

Then find in the technical table the most suitable unit, selecting a gearbox with nominal transmission ratio i_N with a P_{N1} greater than required one in correspondence to n_1 .

Calculate the nominal thermal capacity as:

$$P_{tN} = P_t \cdot f_a$$

Where P_t is the unit thermal capacity and f_a is the ambient correction factor defined from ambient temperature t .

Verify that the nominal thermal capacity P_{tN} is greater than the absorbed motor power P . Otherwise select a fan cooling and re-calculate P_{tN} verifying that it remains greater than the absorbed power. In the case of P_{tN} is still lower than P , select a greater unit or contact the Reggiana Riduttori Technical Service for a heat exchanger sizing.

Example:

Helical unit

- $P = 220$ kW
- $n_1 = 1500$ min^{-1}
- $i_N = 5.6$
- $f_s = 1.75$
- $t = 30^{\circ}\text{C}$

$$P_{N1} = P \cdot f_s = 220 \times 1.75 = 385 \text{ kW}$$

The unit PA 60 $i_N = 5.6$ gives 421 kW at 1500 rpm, hence it should be mechanically suitable for the application required. The thermal capacity without auxiliary cooling is:

$$P_t = P_{tN} \cdot f_a = 180 \times 0.86 = 155 \text{ kW}$$

Since this value is lower than power $P=220$ kW, the extra heat generated must be dissipated by an auxiliary system. Adopting the cooling with 1 fan the thermal capacity becomes:

$$P_t = P_{tN} \cdot f_a = 261 \times 0.94 = 245 \text{ kW}$$

Since $P = 220$ kW is lower than $P_t = 245$ kW, the unit with one fan is convenient.

If the auxiliary fan cooling system is not sufficient, we recommend to consider that a definitive solution to the thermal problem can be achieved with a cooler (oil/ water or oil/air). For medium to large unit sizes, such cooler is cost effective thus guaranteeing the best reliability.



MODULO DI SELEZIONE

SELECTION DATA SHEET

Document references / Riferimenti documento															
Customer name / Nome cliente			Address / Indirizzo			Telephone / Telefono		Project ref n. / Rif. richiesta n°							
Contatto / Contact			E-mail			Fax		Date / Data	Rev.						
Application data / Dati applicazione					Driving machine / Macchina motrice										
Application description Descrizione applicazione					<input type="checkbox"/> Electric motor Motore elettrico <input type="checkbox"/> Hydraulic motor Motore idraulico <input type="checkbox"/> Combustion engine Motore a combustione <input type="checkbox"/> Indirect (with belt drive) Indiretta (con cinghia) <input type="checkbox"/> Other / Altro										
Operating hours per day Ore di funzionamento al giorno				[h]											
Start-up per hour Numero di avviamenti all'ora				[-]											
Time of continuous working Tempo di funzionamento continuo				[min]											
Service factor Fattore di servizio				[-]											
Reduction ratio (min/max) Rapporto di riduzione (min/max)				[-]											
Lifetime required Durata richiesta				[h]											
Environment temperature (min/max) Temperatura ambiente (min/max)				[°C]											
Direction of rotation of output shaft Senso di rotazione albero uscita					<input type="checkbox"/> clockwise / orario (CW) <input type="checkbox"/> counter-clockwise / anti-orario (CCW) <input type="checkbox"/> both directions / entrambi i sensi (CW+CCW)										
Gear unit design / Configurazione riduttore					Lifting requirements / Parametri per sollevamento										
Type Tipo					FEM classification Classificazione FEM										
<input type="checkbox"/> P Helical / Assi paralleli <input type="checkbox"/> RH Horizontal bevel-helical / Assi ortogonali orizzontali <input type="checkbox"/> RV Vertical bevel-helical / Assi ortogonali verticali					Drum diameter Diametro del tamburo										
					[mm]										
<input type="checkbox"/> S Solid / Pieno <input type="checkbox"/> C Hollow with keyway / Cavo con sede linguetta <input type="checkbox"/> UB Hollow with shrink disc / Cavo con unità di bloccaggio <input type="checkbox"/> Other / Altro					Mass to lift Massa da sollevare										
					[kg]										
Output shaft Albero in uscita					Drum mass Massa del tamburo										
[kg]					Winch efficiency Rendimento dell'argano										
Shaft arrangement Esecuzione grafica					Lifting speed (main/auxiliary) Velocità di sollevamento (primaria/ausiliaria)										
<input type="checkbox"/> A <input type="checkbox"/> B <input type="checkbox"/> C <input type="checkbox"/> D <input type="checkbox"/> E <input type="checkbox"/> F <input type="checkbox"/> G <input type="checkbox"/> H <input type="checkbox"/> I <input type="checkbox"/> L <input type="checkbox"/> M <input type="checkbox"/> N					[m/min]										
Mounting position Posizione di montaggio					External reduction (number of falls) Riduzione esterna (numero di tin)										
<input type="checkbox"/> 1 <input type="checkbox"/> 2 <input type="checkbox"/> 3 <input type="checkbox"/> 4 <input type="checkbox"/> 5 <input type="checkbox"/> 6 <input type="checkbox"/> 7					[-]										
<input type="checkbox"/> S Solid / Pieno <input type="checkbox"/> B Pieno + motor flange (IEC/NEMA) Pieno + flangia motore (IEC/NEMA) <input type="checkbox"/> BC Pieno + motor flange (IEC/NEMA) + elastic coupling Pieno + flangia motore (IEC/NEMA) + giunto elastico <input type="checkbox"/> Other / Altro					Drum support type / Tipo di supporto del tamburo										
Mounting of gear unit Fissaggio del riduttore					<input type="checkbox"/> Foot / Piedi <input type="checkbox"/> Flange / Flangia <input type="checkbox"/> Torque arm / Braccio di reazione										
Shaft seals Anelli di tenuta					Double seal / Doppia tenuta <input type="checkbox"/> Labyrinth seal / Tenuta a labirinto <input type="checkbox"/> Viton® <input type="checkbox"/>										
Other accessories Altri accessori					<input type="checkbox"/> Backstop / Antiretro										
Lubrication and cooling / Lubrificazione e raffreddamento															
Lubrication Lubrificazione					<input type="checkbox"/> Splash or bath Sbattimento o bagno <input type="checkbox"/> Forced Forzata										
Lubricant type Tipo di lubrificante															
Additional cooling (if necessary) Raffreddamento ausiliario (se necessario)					<input type="checkbox"/> Fan/Ventola <input type="checkbox"/> Allowed / Permessso <input type="checkbox"/> Not allowed / Non permesso <input type="checkbox"/> Oil-water/Olio-acqua <input type="checkbox"/> Allowed / Permessso <input type="checkbox"/> Not allowed / Non permesso <input type="checkbox"/> Oil-air/Olio-aria <input type="checkbox"/> Allowed / Permessso <input type="checkbox"/> Not allowed / Non permesso										
Cooling water Acqua di raffreddamento					<input type="checkbox"/> Available / Disponibile <input type="checkbox"/> Not available / Non disponibile										
Duty cycle / Ciclo di lavoro															
Output shaft / Albero in uscita					Input shaft / Albero in ingresso										
N.	Time Tempo	Torque Coppia	Speed Velocità	Power Potenza	Radial load Forza radiale	Distance Distanza	Angle Angolo	Axial load Forza assiale	Torque Coppia	Speed Velocità	Power Potenza	Radial load Forza radiale	Distance Distanza	Angle Angolo	Axial load Forza assiale
[-]	[%]	T ₂ [Nm]	n ₂ [min ⁻¹]	P ₂ [kW]	F _{r,2} [N]	x ₂ [mm]	α ₂ [°]	F _{a,2} [N]	T ₁ [Nm]	n ₁ [min ⁻¹]	P ₁ [kW]	F _{r,1} [N]	x ₁ [mm]	α ₁ [°]	F _{a,1} [N]
0*	-														
1															
2															
3															
4															
5															
* Peak operating, starting or braking load / Carico di picco, avviamento o frenatura															
Notes / Note															

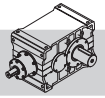

A series of horizontal lines for writing, spanning the width of the page.



DATI TECNICI

TECHNICAL DATA

Riduttori ad assi paralleli PA singolo stadio

PA helical units - single stage

PA		10			20			30			40			50			60							
i _N	n ₁ min ⁻¹	i	n ₂ min ⁻¹	P _{N1} kW	T _{N2} kNm	i	n ₂ min ⁻¹	P _{N1} kW	T _{N2} kNm	i	n ₂ min ⁻¹	P _{N1} kW	T _{N2} kNm	i	n ₂ min ⁻¹	P _{N1} kW	T _{N2} kNm	i	n ₂ min ⁻¹	P _{N1} kW	T _{N2} kNm			
1.12	3000	1.118	2684	708	2.5	1.118	-	-	-	1.147	-	-	-	1.111	-	-	-	1.139	-	-	-			
	1500		1342	374	2.6		1342	532	3.7		1308	801	5.8		1308	1087	7.8		1350	1595	11.1	1317	2079	14.8
	1000		895	255	2.7		895	364	3.8		872	547	5.9		872	744	8		900	1091	11.4	878	1424	15.3
	750		671	194	2.7		671	277	3.9		654	416	6		654	567	8.1		675	830	11.6	659	1085	15.5
1.25	3000	1.25	2400	670	2.6	1.25	2400	946	3.7	1.281	-	-	-	1.235	-	-	-	1.265	-	-	-			
	1500		1200	353	2.8		1200	502	3.9		1171	755	6.1		1171	1041	8.4		1214	1511	11.7	1186	1970	15.6
	1000		800	240	2.8		800	343	4		781	515	6.2		781	711	8.6		810	1032	12	791	1348	16
	750		600	183	2.9		600	261	4.1		585	392	6.3		585	541	8.7		607	785	12.2	593	1026	16.3
1.4	3000	1.4	2143	626	2.7	1.4	2143	893	3.9	1.433	2093	1343	6	1.375	-	-	-	1.406	-	-	-			
	1500		1071	329	2.9		1071	472	4.1		1047	710	6.4		1047	977	8.8		1091	1423	12.3	1067	1860	16.4
	1000		714	224	3		714	322	4.2		698	484	6.5		698	667	9		727	972	12.6	711	1271	16.8
	750		536	170	3		536	245	4.3		523	368	6.6		523	507	9.1		546	739	12.7	533	967	17.1
1.6	3000	1.571	1909	584	2.9	1.571	1909	834	4.1	1.607	1867	1255	6.3	1.621	-	-	-	1.567	-	-	-			
	1500		955	306	3		955	440	4.3		933	661	6.7		933	913	9.2		926	1286	13.1	957	1741	17.1
	1000		636	209	3.1		636	300	4.4		622	450	6.8		622	622	9.4		617	876	13.4	638	1189	17.5
	750		477	158	3.1		477	228	4.5		467	342	6.9		467	473	9.5		463	666	13.5	479	904	17.8
1.8	3000	1.769	1696	541	3	1.769	1696	773	4.3	1.808	1660	1166	6.6	1.815	-	-	-	1.75	-	-	-			
	1500		848	283	3.1		848	407	4.5		830	613	6.9		830	850	9.6		827	1198	13.6	857	1630	17.9
	1000		565	192	3.2		565	277	4.6		553	417	7.1		553	579	9.8		551	815	13.9	571	1111	18.3
	750		424	146	3.2		424	210	4.7		415	317	7.2		415	440	10		413	619	14.1	429	844	18.5
2	3000	2	1500	498	3.1	2	1500	731	4.6	2.042	1469	1067	6.8	2.04	-	-	-	1.962	-	-	-			
	1500		750	260	3.3		750	383	4.8		735	558	7.1		735	781	10		735	1103	14.1	765	1516	18.6
	1000		500	176	3.3		500	260	4.9		490	380	7.3		490	532	10.2		490	750	14.4	510	1032	19
	750		375	134	3.4		375	198	5		367	288	7.4		367	403	10.3		368	569	14.6	382	783	19.3
2.25	3000	2.273	1320	462	3.3	2.273	1320	656	4.7	2.318	1294	988	7.2	2.304	1302	1939	14	2.208	-	-	-			
	1500		660	240	3.4		660	343	4.9		647	516	7.5		647	716	10.4		651	1013	14.6	679	1406	19.5
	1000		440	163	3.5		440	233	5		431	350	7.6		431	486	10.6		434	688	14.9	453	956	19.9
	750		330	123	3.5		330	177	5		324	266	7.7		324	368	10.7		326	522	15.1	340	725	20.1
2.5	3000	2.429	1235	443	3.4	2.429	1235	634	4.8	2.476	1212	948	7.4	2.455	1222	1850	14.2	2.5	1200	2444	19.2			
	1500		618	230	3.5		618	330	5		606	493	7.7		606	682	10.6		611	966	14.9	600	1277	20
	1000		412	156	3.6		412	224	5.1		404	334	7.8		404	463	10.8		407	655	15.1	400	867	20.4
	750		309	118	3.6		309	170	5.2		303	253	7.9		303	351	10.9		306	497	15.3	300	657	20.6
2.8	3000	2.789	1076	401	3.5	2.789	1076	568	5	2.842	1056	853	7.6	2.8	1071	1665	14.6	2.85	1053	2203	19.7			
	1500		538	207	3.6		538	294	5.1		528	442	7.9		528	616	11		536	865	15.2	526	1146	20.5
	1000		359	140	3.7		359	199	5.2		352	299	8		352	417	11.2		357	586	15.4	351	777	20.8
	750		269	106	3.7		269	151	5.3		264	227	8.1		264	316	11.3		268	444	15.6	263	589	21
3.15	3000	3.235	927	358	3.6	3.235	927	512	5.2	3.056	982	808	7.7	3.222	982	1104	10.6	3.053	983	2078	19.9			
	1500		464	184	3.7		464	265	5.4		491	418	8		491	573	11		466	770	15.6	491	1080	20.7
	1000		309	125	3.8		309	179	5.5		327	283	8.1		327	388	11.2		310	521	15.8	328	732	21
	750		232	94.3	3.8		232	136	5.5		246	214	8.2		246	294	11.3		233	394	15.9	246	554	21.2
3.55	3000	3.5	857	336	3.7	3.5	857	482	5.3	3.562	842	714	8	3.471	864	1403	15.3	3.529	850	1880	20.8			
	1500		429	173	3.8		429	249	5.5		421	368	8.2		421	507	11.3		432	724	15.8	425	972	21.5
	1000		286	117	3.9		286	168	5.5		281	249	8.3		281	343	11.5		288	490	16	283	658	21.8
	750		214	88.5	3.9		214	127	5.6		211	188	8.4		211	260	11.6		216	371	16.1	213	498	22
4	3000	4.143	724	258	3.4	4.143	724	382	5	3.867	776	642	7.8	4.067	776	918	11.1	4.133	726	1617	21			
	1500		362	132	3.4		362	195	5.1		388	328	8		388	474	11.5		369	633	16.1	363	833	21.6
	1000		241	89.2	3.5		241	132	5.1		259	221	8		259	320	11.7		246	426	16.3	242	563	21.9
	750		181	67.6	3.5		181	100	5.2		194	168	8.1		194	243	11.8		184	322	16.4	182	425	22.1
4.5	3000	4.538	661	207	2.9	4.538	661	306	4.4	4.615	650	436	6.3	4.429	677	1036	14.4	4.5	667	1376	19.4			
	1500		331	106	3		331	156	4.5		325	222	6.4		325	308	8.9		339	528	14.7	333	702	19.8
	1000		220	71.3	3		220	106	4.5		217	150	6.5		217	208	9		226	356	14.8	222	473	20
	750		165	54	3.1		165	80	4.6		163	114	6.6		163	157	9.1		169	269	14.9	167	357	20.1
5	3000	5	600	158	2.5	5	600	243	3.8	5.083	590	329	5.2	4.846	619	807	12.3	4.923	609	1075	16.6			
	1500		300	80.7	2.5		300	124	3.9		295	168	5.4		295	242	7.7		310	412	12.5	305	548	16.9
	1000		200	54.5	2.6		200	83.7	3.9		197	113	5.4		197	163	7.8		206	278	12.7	203	369	17.1
	750		150	41.3	2.6		150	63.4	4		148	85.9	5.5		148	124	7.9		155	210	12.8	152	279	17.2
5.6	3000	5.545	541	116	2	5.545	541	174	3	5.636	532	240	4.2	5.909	508	440	8.1	5.417	554	824	14			
	1500		271	59.2	2.1		271	89.1	3.1		266	123	4.3		266	172	6.1		254	225	8.3	277	421	14.3
	1000		180	40	2.1		180	60.2	3.1		177	83	4.4		177	116	6.2		169	152	8.4	185	284	14.4
	750		135	30.3	2.1		135	45.6	3.2		133	62.9	4.4		133	88	6.2		127	115	8.5	139	214	14.6

Con lubrificazione forzata – With forced lubrication

Velocità non consentita – Not allowed speed



DATI TECNICI

TECHNICAL DATA

Riduttori ad assi paralleli PA singolo stadio

PA helical units - single stage

PA		70			80			90			100			110							
i _N	n ₁ min ⁻¹	i	n ₂ min ⁻¹	P _{N1} kW	T _{N2} kNm	i	n ₂ min ⁻¹	P _{N1} kW	T _{N2} kNm	i	n ₂ min ⁻¹	P _{N1} kW	T _{N2} kNm	i	n ₂ min ⁻¹	P _{N1} kW	T _{N2} kNm				
1.12	3000	1.118	—	—	—	1.118	—	—	—	1.147	—	—	—	1.147	—	—	—				
	1500		1342	2925	20.5		895	2881	30.3		872	4138	44.6		872	5502	59.4	1.111	900	8024	83.9
	1000		895	2008	21.1		671	2199	30.8		654	3161	45.5		654	4210	60.6	675	6148	85.7	
	750		671	1530	21.4		—	—	—		—	—	—		—	—	—	—	—	—	
1.25	3000	1.25	—	—	—	1.25	—	—	—	1.281	—	—	—	1.281	—	—	—				
	1500		1200	2757	21.6		1200	3960	31		781	3895	46.9		781	5205	62.7	1.235	810	7594	88.2
	1000		800	1890	22.2		600	2075	32.5		585	2973	47.8		585	3978	63.9	607	5813	90.1	
	750		600	1440	22.6		—	—	—		—	—	—		—	—	—	—	—	—	
1.4	3000	1.4	—	—	—	1.4	—	—	—	1.433	—	—	—	1.433	—	—	—				
	1500		1071	2593	22.8		1071	3723	32.7		1047	5326	47.9		698	4897	66	1.375	727	7156	92.5
	1000		714	1775	23.4		714	2554	33.6		698	3658	49.3		523	2789	50.1	546	5471	94.4	
	750		536	1352	23.7		536	1946	34.2		523	2789	50.1		—	—	—	—	—	—	
1.6	3000	1.571	—	—	—	1.571	—	—	—	1.607	—	—	—	1.607	—	—	—				
	1500		955	2427	23.9		636	2385	35.3		622	3412	51.6		622	4591	69.4	1.621	617	6497	99
	1000		636	1659	24.5		477	1816	35.8		467	2599	52.4		467	3501	70.6	463	4960	100.8	
	750		477	1262	24.9		—	—	—		—	—	—		—	—	—	—	—	—	
1.8	3000	1.769	—	—	—	1.769	—	—	—	1.808	—	—	—	1.808	—	—	—				
	1500		848	2255	25		848	3242	36		830	4627	52.5		830	6239	70.7	1.815	551	6053	103.3
	1000		565	1539	25.6		565	2216	36.9		553	3166	53.8		553	4278	72.7	413	4615	105	
	750		424	1170	25.9		424	1686	37.4		415	2409	54.6		—	—	—	—	—	—	
2	3000	2	—	—	—	2	—	—	—	2.042	—	—	—	2.042	—	—	—				
	1500		750	2081	26.1		750	3013	37.8		735	4273	54.7		735	5789	74.1	2.04	490	5591	107.3
	1000		500	1417	26.7		500	2055	38.7		490	2917	56		490	3960	76	368	4260	109	
	750		375	1076	27		375	1562	39.2		367	2218	56.8		367	3014	77.2	—	—	—	
2.25	3000	2.273	—	—	—	2.273	—	—	—	2.318	—	—	—	2.318	—	—	—				
	1500		660	1906	27.2		660	2739	39		647	3910	56.8		647	5325	77.4	2.304	651	7501	108.4
	1000		440	1296	27.7		440	1865	39.9		431	2664	58.1		431	3635	79.3	434	5132	111.2	
	750		330	983	28		330	1416	40.4		324	2024	58.8		324	2763	80.3	326	3906	112.9	
2.5	3000	2.429	—	—	—	2.429	—	—	—	2.476	—	—	—	2.476	—	—	—				
	1500		618	1815	27.6		618	2616	39.8		606	3730	57.9		606	5089	79	2.455	611	7173	110.4
	1000		412	1234	28.2		412	1780	40.7		404	2540	59.1		404	3470	80.8	407	4903	113.2	
	750		309	936	28.5		309	1351	41.1		303	1928	59.9		303	2636	81.9	306	3729	114.8	
2.8	3000	2.789	1076	3134	27.4	2.789	—	—	—	2.842	—	—	—	2.842	—	—	—				
	1500		538	1635	28.6		538	2367	41.4		528	3363	59.9		528	4606	82.1	2.8	536	6505	114.2
	1000		359	1109	29.1		359	1607	42.2		352	2286	61.1		352	3134	83.8	357	4436	116.8	
	750		269	841	29.4		269	1219	42.6		264	1734	61.8		264	2379	84.8	268	3371	118.4	
3.15	3000	3.235	927	2803	28.4	3.235	—	—	—	3.056	—	—	—	3.056	—	—	—				
	1500		464	1456	29.5		464	2097	42.5		491	3174	60.8		491	4362	83.6	3.222	466	5823	117.7
	1000		309	986	30		309	1422	43.3		327	2155	61.9		327	2966	85.3	310	3963	120.1	
	750		232	747	30.3		232	1078	43.7		246	1634	62.6		246	2251	86.3	233	3008	121.5	
3.55	3000	3.5	857	2628	28.8	3.5	857	3789	41.6	3.562	—	—	—	3.562	—	—	—				
	1500		429	1362	29.9		429	1969	43.2		421	2802	62.6		421	3869	86.4	3.471	432	5476	119.2
	1000		286	922	30.4		286	1334	43.9		281	1899	63.6		281	2626	88	288	3723	121.5	
	750		214	698	30.6		214	1010	44.3		211	1439	64.3		211	1990	88.9	216	2824	122.9	
4	3000	4.143	724	2163	28.1	4.143	724	3184	41.4	3.867	776	4996	60.6	3.867	—	—	—				
	1500		362	1105	28.7		362	1646	42.8		388	2591	62.8		388	3554	86.2	4.067	369	4669	119.1
	1000		241	744	29		241	1113	43.4		259	1754	63.8		259	2409	87.6	246	3167	121.1	
	750		181	562	29.2		181	842	43.8		194	1328	64.4		194	1825	88.5	184	2399	122.4	
4.5	3000	4.538	661	1751	24.9	4.538	661	2635	37.5	4.615	650	3691	53.4	4.615	650	5070	73.4	—	—	—	
	1500		331	894	25.5		331	1346	38.3		325	1887	54.6		325	2599	75.2	4.429	339	4125	114.5
	1000		220	602	25.7		220	907	38.7		217	1270	55.1		217	1751	76	226	2796	116.5	
	750		165	455	25.9		165	685	39		163	959	55.5		163	1322	76.5	169	2118	117.6	
5	3000	5	600	1349	21.2	5	600	2021	31.7	5.083	590	2781	44.3	5.083	590	3892	62	—	—	—	
	1500		300	689	21.6		300	1033	32.4		295	1423	45.4		295	1994	63.6	4.846	310	3451	104.9
	1000		200	464	21.8		200	696	32.7		197	958	45.8		197	1343	64.2	206	2325	106	
	750		150	351	22		150	526	33		148	724	46.2		148	1015	64.7	155	1756	106.7	
5.6	3000	5.545	541	974	16.9	5.545	541	1482	25.8	5.636	532	2048	36.2	5.636	532	2784	49.2	508	3627	67.2	
	1500		271	498	17.3		271	758	26.3		266	1048	37		266	1427	50.4	5.909	254	1862	69
	1000		180	336	17.5		180	510	26.6		177	706	37.4		177	961	51	169	1255	69.7	
	750		135	254	17.7		135	386	26.8		133	533	37.7		133	726	51.3	127	948	70.3	

Con lubrificazione forzata – With forced lubrication

Velocità non consentita – Not allowed speed



DATI TECNICI

TECHNICAL DATA

Riduttori ad assi paralleli PB due stadi

PB helical units - double stage

PB		10				20				30				40				50				60							
i_N	n_1 min ⁻¹	i	n_2 min ⁻¹	P_{N1} kW	T_{N2} kNm	i	n_2 min ⁻¹	P_{N1} kW	T_{N2} kNm	i	n_2 min ⁻¹	P_{N1} kW	T_{N2} kNm	i	n_2 min ⁻¹	P_{N1} kW	T_{N2} kNm	i	n_2 min ⁻¹	P_{N1} kW	T_{N2} kNm	i	n_2 min ⁻¹	P_{N1} kW	T_{N2} kNm				
6.3	3000	6.321	475	144	2.8	6.484	463	208	4.2	6.154	488	317	6	6.429	467	421	8.3	6.397	469	697	13.8	6.268	479	965	18.7				
	1500		237	73.7	2.9		231	106	4.3		244	162	6.1		233	215	8.5		235	355	14		239	491	19				
	1000		158	49.8	2.9		154	71.9	4.3		163	109	6.2		156	145	8.6		156	240	14.2		160	331	19.2				
	750		119	37.7	2.9		116	54.5	4.4		122	82.6	6.3		117	110	8.7		117	181	14.3		120	250	19.4				
7.1	3000	7.157	419	128	2.8	6.892	435	196	4.2	6.923	433	283	6	7.278	412	373	8.4	7.263	413	616	13.8	7.096	423	855	18.7				
	1500		210	65.4	2.9		218	100	4.3		217	144	6.2		206	190	8.6		207	314	14.1		211	435	19.1				
	1000		140	44.2	2.9		145	67.8	4.3		144	97.4	6.2		137	129	8.7		138	212	14.2		141	293	19.3				
	750		105	33.5	3		109	51.4	4.4		108	73.8	6.3		103	97.3	8.7		103	160	14.4		106	222	19.4				
8	3000	8.131	369	113	2.8	7.806	384	174	4.2	7.811	384	251	6.1	7.754	387	351	8.4	7.75	387	578	13.8	8.063	372	755	18.8				
	1500		185	57.8	2.9		192	88.9	4.3		192	128	6.2		194	179	8.6		194	295	14.1		186	384	19.1				
	1000		123	39.1	2.9		128	60.1	4.3		128	86.7	6.3		129	121	8.7		129	199	14.3		124	259	19.3				
	750		92.2	29.6	3		96.1	45.6	4.4		96	65.7	6.3		96.7	91.6	8.8		96.8	151	14.4		93	196	19.5				
9	3000	9.283	323	99.4	2.9	8.88	338	154	4.2	8.846	339	223	6.1	8.829	340	309	8.4	8.857	339	508	13.9	9.205	326	664	18.9				
	1500		162	50.8	2.9		169	78.5	4.3		170	114	6.2		170	158	8.6		169	259	14.2		163	338	19.2				
	1000		108	34.4	3		113	53.1	4.4		113	76.8	6.3		113	107	8.7		113	175	14.3		109	228	19.4				
	750		80.8	26.1	3		84.5	40.3	4.4		84.8	58.2	6.4		84.9	80.8	8.8		84.7	132	14.5		81.5	172	19.6				
10	3000	9.941	302	93	2.9	10.158	295	135	4.2	10.07	298	196	6.1	10.11	297	271	8.5	9.49	316	475	13.9	9.857	304	621	18.9				
	1500		151	47.6	2.9		148	69	4.3		149	100	6.2		148	138	8.6		158	242	14.2		152	316	19.2				
	1000		101	32.2	3		98.4	46.7	4.4		99.3	67.8	6.3		98.9	93.5	8.8		105	163	14.4		101	213	19.5				
	750		75.4	24.4	3		73.8	35.4	4.4		74.5	51.4	6.4		74.2	70.9	8.9		79	124	14.5		76.1	161	19.6				
11.2	3000	11.466	262	81	2.9	10.892	275	126	4.2	11.538	260	172	6.1	10.846	277	253	8.5	10.955	274	413	14	11.368	264	540	19				
	1500		131	41.5	2.9		138	64.5	4.3		130	87.9	6.3		138	129	8.7		137	211	14.2		132	275	19.3				
	1000		87.2	28.1	3		91.8	43.6	4.4		86.7	59.5	6.4		92.2	87.4	8.8		91.3	142	14.4		88	186	19.5				
	750		65.4	21.3	3		68.9	33.1	4.5		65	45.1	6.4		69.1	66.3	8.9		68.5	108	14.6		66	140	19.7				
12.5	3000	12.355	243	75.4	2.9	12.607	238	109	4.3	12.389	242	161	6.1	12.564	239	219	8.5	12.765	235	356	14	12.25	245	502	19				
	1500		121	38.6	2.9		119	56	4.4		121	82.1	6.3		119	112	8.7		118	182	14.3		122	256	19.3				
	1000		80.9	26.1	3		79.3	37.9	4.4		80.7	55.6	6.4		79.6	75.9	8.8		78.3	123	14.5		81.6	173	19.6				
	750		60.7	19.8	3		59.5	28.8	4.5		60.5	42.2	6.5		59.7	57.6	8.9		58.8	93.1	14.7		61.2	131	19.8				
14	3000	14.466	207	64.7	2.9	13.615	220	102	4.3	14.389	209	139	6.2	13.575	221	204	8.5	13.839	217	329	14.1	14.344	209	431	19.1				
	1500		104	33.2	3		110	52	4.4		104	71.1	6.3		111	104	8.7		108	168	14.4		105	219	19.4				
	1000		69.1	22.5	3		73.4	35.2	4.4		69.5	48.1	6.4		73.7	70.4	8.9		72.3	114	14.6		69.7	148	19.7				
	750		51.8	17.1	3		55.1	26.7	4.5		52.1	36.5	6.5		55.3	53.4	9		54.2	86.1	14.7		52.3	112	19.9				
16	3000	15.733	191	59.7	2.9	16.036	187	86.7	4.3	15.577	193	129	6.2	16	188	174	8.6	16.449	182	278	14.1	15.6	192	397	19.1				
	1500		95.3	30.6	3		93.5	44.4	4.4		96.3	65.8	6.3		93.8	88.8	8.8		91.2	142	14.4		96.2	202	19.5				
	1000		63.6	20.7	3		62.4	30.1	4.5		64.2	44.6	6.4		62.5	60.2	8.9		60.8	96.2	14.7		64.1	137	19.7				
	750		47.7	15.7	3.1		46.8	22.9	4.5		48.1	33.8	6.5		46.9	45.7	9		45.6	73	14.8		48.1	104	19.9				
18	3000	17.181	175	54.8	2.9	17.505	171	79.6	4.3	18.462	163	109	6.2	17.473	172	159	8.6	18.055	166	254	14.2	18.692	161	333	19.2				
	1500		87.3	28.1	3		85.7	40.8	4.4		81.3	55.9	6.4		85.8	81.6	8.8		83.1	130	14.5		80.2	170	19.6				
	1000		58.2	19.1	3		57.1	27.7	4.5		54.2	37.9	6.5		57.2	55.3	8.9		55.4	87.9	14.7		53.5	115	19.9				
	750		43.7	14.5	3.1		42.8	21	4.5		40.6	28.8	6.6		42.9	42	9.1		41.5	66.7	14.9		40.1	86.9	20.1				
20	3000	20.801	144	45.6	2.9	19.201	156	72.8	4.3	20.237	148	99.8	6.2	19.172	157	146	8.6	19.929	151	231	14.2	20.625	146	302	19.3				
	1500		72.1	23.4	3		78.1	37.4	4.4		74.1	51.2	6.4		78.2	74.6	8.8		75.3	118	14.5		72.7	154	19.7				
	1000		48.1	15.9	3.1		52.1	25.3	4.5		49.4	34.7	6.5		52.2	50.6	9		50.2	80	14.8		48.5	104	19.9				
	750		36.1	12.1	3.1		39.1	19.3	4.6		37.1	26.4	6.6		39.1	38.4	9.1		37.6	60.7	14.9		36.4	79.1	20.1				
22.5	3000									22.308	135	90.9	6.3									22.909	131	273	19.3				
	1500																												
	1000																												
	750																												

Con lubrificazione forzata – With forced lubrication

Velocità non consentita – Not allowed speed



DATI TECNICI

TECHNICAL DATA

Riduttori ad assi paralleli PB due stadi

PB helical units - double stage

PB		70				80				90				100				110			
i_N	n_1 min ⁻¹	i	n_2 min ⁻¹	P_{N1} kW	T_{N2} kNm	i	n_2 min ⁻¹	P_{N1} kW	T_{N2} kNm	i	n_2 min ⁻¹	P_{N1} kW	T_{N2} kNm	i	n_2 min ⁻¹	P_{N1} kW	T_{N2} kNm	i	n_2 min ⁻¹	P_{N1} kW	T_{N2} kNm
6.3	3000	6.321	—	—	—	6.484	—	—	—	6.154	—	—	—	6.429	—	—	—	6.397	—	—	—
	1500		237	626	24.4		231	919	36.8		244	1376	52.3		233	1817	72.1		235	2919	115.3
	1000		158	422	24.7		154	619	37.2		163	926	52.8		156	1224	72.9		156	1965	116.4
	750		119	319	24.9		116	468	37.4		122	700	53.2		117	924	73.4		117	1484	117.2
7.1	3000	7.157	419	1089	24.1	6.892	—	—	—	6.923	—	—	—	7.278	—	—	—	7.263	—	—	—
	1500		210	555	24.5		218	866	36.8		217	1227	52.5		206	1610	72.4		207	2579	115.7
	1000		140	374	24.8		145	583	37.2		144	826	53		137	1084	73.1		138	1736	116.8
	750		105	283	25		109	441	37.5		108	624	53.4		103	819	73.6		103	1311	117.6
8	3000	8.131	369	962	24.2	7.806	—	—	—	7.811	—	—	—	7.754	—	—	—	7.75	—	—	—
	1500		185	490	24.6		192	767	37		192	1091	52.6		194	1513	72.5		194	2420	115.9
	1000		123	330	24.9		128	516	37.3		128	734	53.1		129	1019	73.2		129	1629	117
	750		92.2	250	25.1		96.1	390	37.6		96	555	53.5		96.7	770	73.8		96.8	1231	117.8
9	3000	9.283	323	846	24.2	8.88	338	1329	36.4	8.846	—	—	—	8.829	—	—	—	8.857	—	—	—
	1500		162	430	24.7		169	676	37.1		170	966	52.8		170	1333	72.7		169	2124	116.2
	1000		108	290	25		113	456	37.5		113	650	53.3		113	898	73.5		113	1430	117.4
	750		80.8	220	25.2		84.5	345	37.8		84.8	492	53.7		84.9	679	74		84.7	1081	118.2
10	3000	9.941	302	791	24.3	10.158	295	1166	36.6	10.07	298	1674	52.1	10.11	—	—	—	10.186	—	—	—
	1500		151	403	24.7		148	593	37.2		149	851	52.9		148	1168	73		147	1853	116.6
	1000		101	272	25		98.4	400	37.6		99.3	573	53.5		98.9	787	73.7		98.2	1248	117.8
	750		75.4	205	25.2		73.8	302	37.9		74.5	434	53.9		74.2	595	74.3		73.6	943	118.7
11.2	3000	11.466	262	688	24.4	10.892	275	1089	36.6	11.538	260	1466	52.2	10.846	—	—	—	10.955	—	—	—
	1500		131	350	24.8		138	554	37.3		130	745	53.1		138	1091	73.1		137	1726	116.8
	1000		87.2	236	25.1		91.8	374	37.7		86.7	502	53.7		92.2	735	73.9		91.3	1163	118
	750		65.4	179	25.3		68.9	283	38		65	380	54.1		69.1	556	74.5		68.5	879	118.9
12.5	3000	12.355	243	640	24.4	12.607	238	944	36.8	12.389	242	1368	52.3	12.564	239	1858	72.1	12.765	—	—	—
	1500		121	326	24.9		119	481	37.4		121	695	53.2		119	945	73.4		118	1487	117.2
	1000		80.9	220	25.2		79.3	324	37.9		80.7	469	53.8		79.6	637	74.2		78.3	1002	118.5
	750		60.7	167	25.4		59.5	245	38.2		60.5	355	54.3		59.7	482	74.8		58.8	758	119.5
14	3000	14.466	207	549	24.5	13.615	220	876	36.8	14.389	209	1182	52.5	13.575	221	1723	72.2	13.839	217	2703	115.5
	1500		104	280	25		110	446	37.5		104	601	53.4		111	877	73.5		108	1374	117.5
	1000		69.1	189	25.3		73.4	301	37.9		69.5	405	54		73.7	591	74.3		72.3	926	118.7
	750		51.8	143	25.5		55.1	228	38.3		52.1	307	54.5		55.3	447	75		54.2	701	119.8
16	3000	15.733	191	506	24.6	16.036	187	747	37	15.577	193	1094	52.6	16	188	1468	72.5	16.449	182	2284	116
	1500		95.3	258	25		93.5	380	37.7		96.3	556	53.5		93.8	747	73.8		91.2	1161	118
	1000		63.6	174	25.4		62.4	257	38.1		64.2	375	54.2		62.5	504	74.7		60.8	783	119.3
	750		47.7	132	25.6		46.8	194	38.5		48.1	284	54.7		46.9	381	75.4		45.6	593	120.4
18	3000	17.181	175	464	24.6	17.505	171	686	37.1	18.462	163	926	52.8	17.473	172	1347	72.7	18.055	166	2085	116.3
	1500		87.3	237	25.1		85.7	349	37.8		81.3	472	53.8		85.8	686	74		83.1	1061	118.3
	1000		58.2	160	25.4		57.1	236	38.3		54.2	318	54.5		57.2	463	74.9		55.4	715	119.7
	750		43.7	121	25.7		42.8	179	38.6		40.6	241	55		42.9	350	75.6		41.5	541	120.8
20	3000	20.801	144	385	24.8	19.201	156	627	37.1	20.237	148	847	52.9	19.172	157	1231	72.9	19.929	151	1894	116.5
	1500		72.1	197	25.3		78.1	319	37.9		74.1	432	53.9		78.2	627	74.2		75.3	964	118.6
	1000		48.1	133	25.6		52.1	216	38.4		49.4	291	54.6		52.2	423	75.1		50.2	650	120
	750		36.1	101	25.9		39.1	163	38.8		37.1	221	55.2		39.1	320	75.8		37.6	492	121.2
22.5	3000	23.105	130	348	24.8	23.517	128	514	37.3	22.308	135	770	53.1	23.497	128	1009	73.2	22.143	136	1635	111.8
	1500		64.9	178	25.4		63.8	262	38.1		67.2	393	54.1		63.8	514	74.6		67.7	832	113.7
	1000		43.3	120	25.7		42.5	177	38.6		44.8	265	54.8		42.6	347	75.6		45.2	559	114.8
	750		32.5	91.1	26		31.9	134	39.1		33.6	201	55.4		31.9	263	76.4		33.9	422	115.5

Con lubrificazione forzata – With forced lubrication

Velocità non consentita – Not allowed speed



DATI TECNICI

TECHNICAL DATA

Riduttori ad assi paralleli PC tre stadi

PC helical units - triple stage

PC		70				80				90				100				110								
i _N	n ₁ min ⁻¹	i	n ₂ min ⁻¹	P _{N1} kW	T _{N2} kNm	i	n ₂ min ⁻¹	P _{N1} kW	T _{N2} kNm	i	n ₂ min ⁻¹	P _{N1} kW	T _{N2} kNm	i	n ₂ min ⁻¹	P _{N1} kW	T _{N2} kNm	i	n ₂ min ⁻¹	P _{N1} kW	T _{N2} kNm					
22.5	3000																									
	1500																									
	1000																									
	750																									
25	3000	25.655		117	319	24.9	25.415		118	484	37.4	24.399		-	-	-	24.566		-	-	-	25.243		-	-	-
	1500		58.5	163	25.4	59		247	38.2	61.5	365		54.2	61.1	500	74.7		59.4	778	119.4						
	1000		39	110	25.8	39.3		167	38.8	41	247		55	40.7	338	75.7		39.6	525	121						
	750		29.2	83.6	26.1	29.5		127	39.2	30.5	187		55.5	30.5	256	76.5		29.7	398	122.2						
28	3000	27.257		110	301	24.9	28.744		104	430	37.6	27.513		-	-	-	27.719		-	-	-	28.469		-	-	-
	1500		55	154	25.5	52.2		219	38.4	54.5	325		54.4	54.1	445	75		52.7	692	119.9						
	1000		36.7	104	25.9	34.8		148	38.9	36.3	220		55.2	36.1	301	76.1		35.1	467	121.4						
	750		27.5	78.9	26.2	26.1		113	39.4	27.3	167		55.8	27.1	228	76.9		26.3	354	122.7						
31.5	3000	30.817		97.3	267	25	32.584		92.1	380	37.7	31.071		96.6	566	53.5	31.339		-	-	-	32.192		-	-	-
	1500		48.7	137	25.6	46		194	38.5	48.3	289		54.7	47.9	395	75.3		46.6	614	120.3						
	1000		32.4	92.4	26	30.7		132	39.1	32.2	196		55.5	31.9	267	76.4		31.1	415	122						
	750		24.3	70.1	26.3	23		99.8	39.6	24.1	148		56.1	23.9	203	77.2		23.3	315	123.3						
35.5	3000	34.946		85.8	236	25.1	34.734		86.4	357	37.8	35.178		85.3	502	53.7	35.538		84.4	685	74	36.536		82.1	1065	118.3
	1500		42.9	121	25.7	43.2		183	38.6	42.6	257		54.9	42.2	350	75.6		41.1	544	120.8						
	1000		28.6	81.9	26.1	28.8		124	39.2	28.4	174		55.7	28.1	237	76.7		27.4	368	122.5						
	750		21.5	62.2	26.4	21.6		93.8	39.7	21.3	132		56.3	21.1	179	77.6		20.5	279	123.9						
40	3000	39.794		75.4	208	25.2	39.596		75.8	315	37.9	39.968		75.1	443	53.9	40.468		74.1	604	74.3	38.991		76.9	999	118.5
	1500		37.7	107	25.8	37.9		161	38.8	37.5	227		55.1	37.1	309	76		38.5	510	121.1						
	1000		25.1	72.3	26.3	25.3		109	39.4	25	154		56	24.7	209	77.1		25.6	345	122.8						
	750		18.8	54.9	26.6	18.9		82.8	39.9	18.5	116		56.6	18.5	158	78		19.2	261	124						
45	3000	45.565		65.8	183	25.3	45.385		66.1	276	38.1	45.629		65.7	390	54.1	46.337		64.7	529	74.6	44.602		67.3	877	119
	1500		32.9	93.7	26	33.1		141	39	32.9	200		55.4	32.4	271	76.3		33.6	448	121.6						
	1000		21.9	63.5	26.4	22		95.7	39.6	21.9	135		56.3	21.6	183	77.5		22.4	303	123.4						
	750		16.5	48.2	26.7	16.5		72.6	40.1	16.4	103		56.9	16.2	139	78.4		16.8	229	124.4						
50	3000	48.883		61.4	171	25.4	48.713		61.6	258	38.2	48.864		61.4	365	54.2	49.712		60.3	494	74.8	51.395		58.4	764	119.5
	1500		30.7	87.6	26	30.8		132	39.1	30.7	187		55.5	30.2	253	76.5		29.2	391	122.2						
	1000		20.5	59.4	26.5	20.5		89.4	39.7	20.5	127		56.4	20.1	171	77.7		19.5	264	124						
	750		15.3	45.1	26.8	15.4		67.9	40.2	15.3	96		57.1	15.1	130	78.7		14.6	200	124.7						
56	3000	56.626		53	148	25.5	56.479		53.1	223	38.3	56.356		53.2	318	54.5	57.585		52.1	429	75.1	55.357		54.2	711	119.8
	1500		26.5	76.1	26.2	26.6		115	39.3	26.6	163		55.8	26	220	77		27.1	364	122.6						
	1000		17.7	51.6	26.6	17.7		77.6	40	17.7	110		56.8	17.4	149	78.2		18.1	246	124.2						
	750		13.2	39.2	27	13.3		58.9	40.5	13.3	83.8		57.5	13	113	79.1		13.5	186	124.9						
63	3000	61.18		49	138	25.6	61.047		49.1	207	38.5	60.726		49.4	296	54.6	62.217		48.2	398	75.3	64.768		46.3	611	120.3
	1500		24.5	70.6	26.3	24.6		106	39.5	24.7	152		56	24.1	204	77.2		23.2	313	123.3						
	1000		16.3	47.9	26.7	16.4		72	40.1	16.5	103		56.9	16.1	138	78.5		15.4	211	124.6						
	750		12.3	36.4	27.1	12.3		54.7	40.6	12.4	78		57.6	12.1	105	79.4		11.6	159	125.3						
71	3000	72.111		41.6	117	25.8	72.01		41.7	177	38.7	71.106		42.2	254	54.9	73.333		40.9	339	75.7	70.414		42.6	563	120.7
	1500		20.8	60.3	26.5	20.8		90.7	39.7	21.1	130		56.4	20.5	174	77.7		21.3	289	123.7						
	1000		13.9	40.9	26.9	13.9		61.5	40.4	14.1	88.3		57.3	13.6	118	79		14.2	194	124.8						
	750		10.4	31.1	27.3	10.4		46.7	40.9	10.5	67.1		58.1	10.2	89.6	79.9		10.7	147	125.5						
80	3000	78.748		38.1	108	25.8	78.667		38.1	162	38.8	77.333		38.8	234	55.1	80.082		37.5	312	76	76.867		39	518	121
	1500		19	55.4	26.6	19.1		83.3	39.9	19.4	120		56.6	18.7	160	78		19.5	265	124						
	1000		12.7	37.6	27	12.7		56.5	40.6	12.9	81.5		57.5	12.5	109	79.3		13	178	125						
	750		9.5	28.6	27.4	9.5		42.9	41.1	9.7	61.9		58.3	9.4	82.4	80.2		9.8	134	125.8						
90	3000	86.405		34.7	98.6	25.9	86.347		34.7	148	38.9	92.663		32.4	197	55.4	87.87		34.1	285	76.2	93		32.3	431	121.8
	1500		17.4	50.7	26.7	17.4		76.2	40	16.2	101		57	17.1	146	78.3		16.1	220	124.5						
	1000		11.6	34.4	27.2	11.6		51.7	40.7	10.8	68.6		58	11.4	99.2	79.6		10.8	148	125.5						
	750		8.7	26.2	27.5	8.7		39.3	41.3	8.1	52.1		58.8	8.5	75.4	80.6		8.1	112	126.2						
100	3000	95.339		31.5	89.7	26	105.9		28.3	122	39.2	102.24		29.3	179	55.6	96.955		30.9	259	76.5	103.27		29.1	389	122.3
	1500		15.7	46.2	26.8	14.2		62.7	40.4	14.7	92		57.2	15.5	133	78.6		14.5	199	124.8						
	1000		10.5	31.3	27.3	9.4		42.6	41.1	9.8	62.4		58.3	10.3	90.3	79.9		9.7	134	125.8						
	750		7.9	23.8	27.6	7.1		32.5	41.8	7.3	47.4		59	7.7	68.6	80.9		7.3	101	126.5						
112	3000																									
	1500																									
	1000																									
	750																									

Con lubrificazione forzata – With forced lubrication

Velocità non consentita – Not allowed speed



DATI TECNICI

TECHNICAL DATA

Riduttori ad assi paralleli PD quattro stadi

PD helical units - quadruple stage

PD		70				80				90				100				110						
i _N	n ₁ min ⁻¹	i	n ₂ min ⁻¹	P _{N1} kW	T _{N2} kNm	i	n ₂ min ⁻¹	P _{N1} kW	T _{N2} kNm	i	n ₂ min ⁻¹	P _{N1} kW	T _{N2} kNm	i	n ₂ min ⁻¹	P _{N1} kW	T _{N2} kNm	i	n ₂ min ⁻¹	P _{N1} kW	T _{N2} kNm			
100	3000																							
	1500																							
	1000																							
	750																							
112	3000	110.72	27.1	78.9	26.2	113.75	26.4	115	39.3	114.64	26.2	163	55.9	111.6	26.9	367	122.6							
	1500		13.5	40.6	27		13.2	59.4	40.5		13.1	83.7	57.5		13.4	187	124.9							
	1000		9	27.6	27.5		8.8	40.4	41.3		8.7	56.8	58.6		9	126	126							
	750		6.8	21.2	28.1		6.6	31	42.3		6.5	43.6	60		6.7	94.7	126.7							
125	3000	124.93	24	70.3	26.3	128.17	23.4	103	39.5	121.41	24.7	154	56	127.05	23.6	203	77.3	126.21						
	1500		12	36.2	27.1		11.7	53	40.7		12.4	79.2	57.6		11.8	104	79.5							
	1000		8	24.6	27.6		7.8	36	41.5		8.2	53.8	58.7		7.9	70.8	80.9							
	750		6	19.1	28.6		5.9	28	43.1		6.2	41.6	60.5		5.9	54.9	83.6							
140	3000	141.24	21.2	62.5	26.4	136.15	22	97.1	39.6	136.32	22	138	56.3	143.64	20.9	180	77.6	143.08						
	1500		10.6	32.2	27.3		11	50	40.8		11	70.9	57.9		10.4	92.8	79.9							
	1000		7.1	22	27.9		7.3	34	41.6		7.3	48.2	59		7	63.2	81.6							
	750		5.3	17.2	29.1		5.5	26.6	43.5		5.5	37.7	61.6		5.2	49.4	85.1							
160	3000	160.17	18.7	55.4	26.6	163.93	18.3	81.3	39.9	162.83	18.4	116	56.7	162.88	18.4	160	78	162.75						
	1500		9.4	28.6	27.4		9.2	41.9	41.2		9.2	59.9	58.4		9.2	82.3	80.3							
	1000		6.2	19.7	28.4		6.1	29	42.8		6.1	41.4	60.5		6.1	56.8	83.1							
	750		4.7	15.5	29.7		4.6	22.8	44.7		4.6	32.4	63.3		4.6	44.4	86.7							
180	3000	182.39	16.4	48.9	26.7	174.73	17.2	76.5	40	184.04	16.3	103	57	185.48	16.2	141	78.4	186						
	1500		8.2	25.2	27.6		8.6	39.4	41.3		8.2	53.3	58.7		8.1	72.7	80.8							
	1000		5.5	17.7	29		5.7	27.5	43.2		5.4	37.3	61.7		5.4	50.8	84.7							
	750		4.1	13.9	30.3		4.3	21.6	45.2		4.1	29.2	64.5		4	39.5	87.7							
200	3000	208.84	14.4	43	26.9	199.28	15.1	67.4	40.3	195.97	15.3	97.3	57.1	198.32	15.1	132	78.6	199.29						
	1500		7.2	22.2	27.8		7.5	34.8	41.6		7.7	50.2	58.9		7.6	68.2	81							
	1000		4.8	15.8	29.6		5	24.6	44.1		5.1	35.4	62.3		5	48	85.5							
	750		3.6	12.4	30.9		3.8	19	45.4		3.8	27.6	64.7		3.8	37	87.8							
225	3000	224.05	13.4	40.2	27	228.74	13.1	59.1	40.5	223.08	13.4	85.9	57.4	227.85	13.2	116	79.1	230.05						
	1500		6.7	20.9	28.1		6.6	30.9	42.3		6.7	44.7	59.7		6.6	60.3	82.3							
	1000		4.5	14.9	29.9		4.4	21.9	45.1		4.5	31.7	63.5		4.4	42.6	87.3							
	750		3.3	11.5	31		3.3	16.6	45.5		3.4	24.3	64.9		3.3	32.3	88.1							
250	3000	240.86	12.5	37.5	27.1	245.79	12.2	55.2	40.6	255.61	11.7	75.4	57.8	244.94	12.2	108	79.3	248						
	1500		6.2	19.7	28.4		6.1	29.1	42.8		5.9	39.8	61		6.1	56.6	83.1							
	1000		4.2	14	30.3		4.1	20.5	45.3		3.9	28.2	64.7		4.1	39.8	87.7							
	750		3.1	10.7	31		3.1	15.5	45.6		2.9	21.2	65.1		3.1	30	88.2							
280	3000	280.41	10.7	32.4	27.2	285.92	10.5	47.8	40.9	274.44	10.9	70.5	58	285.16	10.5	93.4	79.8	290.63						
	1500		5.3	17.3	29.1		5.2	25.6	43.8		5.5	37.5	61.6		5.3	49.7	85							
	1000		3.6	12.3	30.9		3.5	17.7	45.5		3.6	26.3	64.8		3.5	34.3	88							
	750		2.7	9.3	31.1		2.6	13.3	45.7		2.7	19.8	65.2		2.6	25.9	88.4							
315	3000	303.89	9.9	30	27.3	309.75	9.7	44.3	41.1	318.76	9.4	61.1	58.4	309.04	9.7	86.5	80.1	316.2						
	1500		4.9	16.2	29.5		4.8	23.9	44.3		4.7	33	63.1		4.9	46.4	86							
	1000		3.3	11.3	31		3.2	16.4	45.5		3.1	22.7	65		3.2	31.7	88.1							
	750		2.5	8.6	31.2		2.4	12.3	45.8		2.4	17.1	65.4		2.4	23.9	88.6							
355	3000	360.93	8.3	25.5	27.6	367.62	8.2	37.6	41.4	345.07	8.7	56.6	58.6	367.04	8.2	73.4	80.7	345.43						
	1500		4.2	14	30.3		4.1	20.6	45.3		4.3	30.9	63.8		4.1	39.9	87.7							
	1000		2.8	9.6	31.1		2.7	13.8	45.7		2.9	21	65.1		2.7	26.8	88.4							
	750		2.1	7.2	31.3		2	10.4	46		2.2	15.8	65.5		2	20.2	88.9							
400	3000	396.02	7.6	23.3	27.7	403.23	7.4	34.4	41.6	408.97	7.3	48.2	59	402.74	7.4	67.2	81.1	418.5						
	1500		3.8	12.9	30.7		3.7	18.8	45.4		3.7	26.4	64.8		3.7	36.4	87.9							
	1000		2.5	8.8	31.2		2.5	12.6	45.8		2.4	17.8	65.3		2.5	24.5	88.5							
	750		1.9	6.6	31.3		1.9	9.5	46		1.8	13.4	65.7		1.9	18.4	89							
450	3000	436.97	6.9	21.4	28	444.77	6.7	31.6	42.1	448.3	6.7	44.5	59.8	444.38	6.8	61.6	82	465						
	1500		3.4	11.8	31		3.4	17.1	45.5		3.3	24.2	64.9		3.4	33.1	88							
	1000		2.3	7.9	31.2		2.2	11.5	45.9		2.2	16.2	65.4		2.3	22.2	88.7							
	750		1.7	6	31.4		1.7	8.7	46.1		1.7	12.2	65.8		1.7	16.7	89.2							
500	3000	485.36	6.2	19.6	28.5	493.87	6.1	28.9	42.8	494.18	6.1	41	60.6	493.59	6.1	56.3	83.2							
	1500		3.1	10.7	31		3	15.4	45.6		3	22	65		3	29.8	88.2							
	1000		2.1	7.2	31.3		2	10.4	46		2	14.8	65.5		2	20	88.9							
	750		1.5	5.4	31.4		1.5	7.8	46.2		1.5	11.1	65.9		1.5	15.1	89.4							

Con lubrificazione forzata – With forced lubrication

Velocità non consentita – Not allowed speed



DATI TECNICI

TECHNICAL DATA

Riduttori ad assi ortogonali RHB/RVB due stadi *RHB/RVB bevel-helical units - double stage*

RHB RVB		10				20				30				40				50				60			
i_N	n_1 min ⁻¹	i	n_2 min ⁻¹	P_{N1} kW	T_{N2} kNm	i	n_2 min ⁻¹	P_{N1} kW	T_{N2} kNm	i	n_2 min ⁻¹	P_{N1} kW	T_{N2} kNm	i	n_2 min ⁻¹	P_{N1} kW	T_{N2} kNm	i	n_2 min ⁻¹	P_{N1} kW	T_{N2} kNm	i	n_2 min ⁻¹	P_{N1} kW	T_{N2} kNm
5	3000	5.078	591	147	2.3	5.078	591	212	3.3	5.177	579	287	4.6	5.177	579	403	6.4	5.132	585	546	8.7	4.909	611	757	11.5
	1500		295	75.9	2.4		295	109	3.4		290	148	4.7		290	208	6.7		292	283	9		306	393	11.9
	1000		197	51.3	2.4		197	73.8	3.5		193	100	4.8		193	141	6.8		195	192	9.1		204	266	12.1
	750		148	38.8	2.4		148	55.8	3.5		145	75.8	4.8		145	107	6.8		146	145	9.2		153	202	12.2
5.6	3000	5.436	552	147	2.5	5.436	552	212	3.6	5.541	541	287	4.9	5.541	541	403	6.9	5.476	548	546	9.2	5.576	538	757	13
	1500		276	75.9	2.5		276	109	3.7		271	148	5.1		271	208	7.1		274	283	9.6		269	393	13.5
	1000		184	51.3	2.6		184	73.8	3.7		181	100	5.1		181	141	7.2		183	192	9.7		179	266	13.8
	750		138	38.8	2.6		138	55.8	3.7		135	75.8	5.2		135	107	7.3		137	145	9.8		135	202	13.9
6.3	3000	6.273	478	147	2.9	6.273	478	212	4.1	6.389	470	287	5.7	6.389	470	403	7.9	6.273	478	546	10.6	6.383	470	757	14.9
	1500		239	75.9	2.9		239	109	4.2		235	148	5.8		235	208	8.2		239	283	11		235	393	15.5
	1000		159	51.3	3		159	73.8	4.3		157	100	5.9		157	141	8.3		159	192	11.1		157	266	15.7
	750		120	38.8	3		120	55.8	4.3		117	75.8	6		117	107	8.4		120	145	11.2		118	202	15.9
7.1	3000	7.318	410	147	3.3	7.318	410	212	4.8	6.888	436	287	6.1	6.888	436	403	8.6	7.257	413	546	12.2	6.854	438	757	16
	1500		205	75.9	3.4		205	109	4.9		218	148	6.3		218	208	8.9		207	283	12.7		219	393	16.6
	1000		137	51.3	3.5		137	73.8	5		145	100	6.4		145	141	9		138	192	12.9		146	266	16.9
	750		103	38.8	3.5		103	55.8	5		109	75.8	6.4		109	107	9.1		103	145	13		109	202	17.1
8	3000	7.945	378	139	3.4	7.945	378	205	5	8.085	371	287	7.2	8.085	371	403	10.1	7.841	383	546	13.2	7.972	376	757	18.6
	1500		189	71	3.5		189	105	5.2		186	148	7.4		186	208	10.4		191	283	13.7		188	393	19.4
	1000		126	48.2	3.5		126	71.3	5.2		124	100	7.5		124	141	10.6		128	192	13.9		125	266	19.7
	750		94.4	36.6	3.6		94.4	54.1	5.3		92.8	75.8	7.6		92.8	107	10.7		95.7	145	14		94.1	202	19.9
9	3000	8.662	346	120	3.2	8.662	346	178	4.8	8.812	341	258	7	8.812	341	376	10.2	9.26	324	486	13.9	8.642	347	757	20.2
	1500		173	61.6	3.3		173	91.2	4.9		170	132	7.2		170	192	10.4		162	248	14.2		174	393	21
	1000		115	41.8	3.4		115	61.8	5		114	89.4	7.3		114	129	10.6		108	167	14.4		116	266	21.3
	750		86.6	31.8	3.4		86.6	47	5		85.1	67.9	7.4		85.1	98	10.7		81	127	14.5		86.8	202	21.5
10	3000	10.455	287	74.4	2.4	10.455	287	114	3.7	9.65	311	205	6.1	9.65	311	284	8.4	10.133	296	379	11.9	10.294	291	507	16.1
	1500		144	38.1	2.5		144	58.4	3.8		155	105	6.2		155	145	8.6		148	193	12.1		146	258	16.4
	1000		95.7	25.8	2.5		95.7	39.5	3.8		104	70.7	6.3		104	97.8	8.7		98.7	131	12.3		97.1	174	16.6
	750		71.7	19.6	2.5		71.7	30	3.9		77.7	53.6	6.4		77.7	74.2	8.8		74	99	12.4		72.9	132	16.8
11.2	3000	11.595	259	54.6	2	11.595	259	82	2.9	11.785	255	113	4.1	11.785	255	158	5.8	11.152	269	288	9.9	11.326	265	387	13.5
	1500		129	27.9	2		129	42	3		127	57.9	4.2		127	81	5.9		135	147	10.1		132	198	13.8
	1000		86.2	18.9	2		86.2	28.4	3.1		84.9	39.2	4.3		84.9	54.8	6		89.7	99.4	10.3		88.3	133	14
	750		64.7	14.4	2.1		64.7	21.6	3.1		63.6	29.7	4.3		63.6	41.6	6.1		67.3	75.4	10.4		66.2	101	14.1
12.5	3000	12.16	247	59.5	2.2	12.16	247	85.7	3.2	12.373	243	119	4.5	12.373	243	171	6.5	12	250	237	8.8	12.2	246	336	12.7
	1500		123	30.4	2.3		123	43.8	3.3		121	60.7	4.6		121	87.2	6.7		125	121	9		123	172	12.9
	1000		82.2	20.6	2.3		82.2	29.6	3.3		80.8	41	4.7		80.8	58.8	6.7		83.3	81.7	9.1		82	116	13.1
	750		61.7	15.6	2.3		61.7	22.4	3.4		60.6	31	4.7		60.6	44.5	6.8		62.5	61.8	9.2		61.5	87.6	13.2
14	3000	14.523	207	59.5	2.7	14.523	207	85.7	3.8	13.486	223	119	4.9	13.486	223	171	7.1	14.171	212	237	10.4	14.4	208	336	14.9
	1500		103	30.4	2.7		103	43.8	3.9		111	60.7	5.1		111	87.2	7.3		106	121	10.6		104	172	15.3
	1000		68.9	20.6	2.8		68.9	29.6	4		74.2	41	5.1		74.2	58.8	7.4		70.6	81.7	10.7		69.4	116	15.5
	750		51.6	15.6	2.8		51.6	22.4	4		55.6	31	5.2		55.6	44.5	7.4		52.9	61.8	10.8		52.1	87.6	15.6
16	3000	16	188	49.3	2.4	16	188	75.6	3.7	16.267	184	102	5.1	16.267	184	148	7.4	15.508	194	237	11.4	15.754	190	335	16.3
	1500		93.8	25.3	2.5		93.8	38.8	3.8		92.2	52.5	5.3		92.2	75.5	7.6		96.7	121	11.6		95.2	171	16.6
	1000		62.5	17.1	2.5		62.5	26.3	3.9		61.5	35.6	5.4		61.5	51.1	7.7		64.5	81.7	11.7		63.5	115	16.8
	750		46.9	13	2.6		46.9	20	3.9		46.1	27	5.4		46.1	38.8	7.8		48.4	61.8	11.8		47.6	87.4	17
18	3000	17.745	169	36.2	2	17.745	169	54.3	3	18.036	166	74.9	4.2	18.036	166	105	5.8	17.067	176	191	10	17.333	173	256	13.7
	1500		84.5	18.6	2		84.5	27.9	3.1		83.2	38.4	4.3		83.2	53.8	6		87.9	97.5	10.3		86.5	131	14
	1000		56.4	12.6	2.1		56.4	18.9	3.1		55.4	26.1	4.4		55.4	36.4	6.1		58.6	66	10.4		57.7	88.5	14.2
	750		42.3	9.6	2.1		42.3	14.4	3.2		41.6	19.8	4.4		41.6	27.7	6.2		43.9	50.1	10.6		43.3	67.1	14.4

Con lubrificazione forzata – *With forced lubrication*

Velocità non consentita – *Not allowed speed*



DATI TECNICI

TECHNICAL DATA

Riduttori ad assi ortogonali RHB/RVB due stadi *RHB/RVB bevel-helical units - double stage*

RHB RVB		70				80				90				100				110			
i_N	n_1 min ⁻¹	i	n_2 min ⁻¹	P_{N1} kW	T_{N2} kNm	i	n_2 min ⁻¹	P_{N1} kW	T_{N2} kNm	i	n_2 min ⁻¹	P_{N1} kW	T_{N2} kNm	i	n_2 min ⁻¹	P_{N1} kW	T_{N2} kNm	i	n_2 min ⁻¹	P_{N1} kW	T_{N2} kNm
5	3000	5.078	591	1064	16.7	5.078	—	—	—	5.143	—	—	—	5.129	—	—	—	5.063	—	—	—
	1500		295	553	17.3		295	773	24.3		292	947	30.1		292	1237	39.2		296	1478	46.2
	1000		197	375	17.6		197	525	24.7		194	645	30.7		195	845	40.2		198	1014	47.6
	750		148	284	17.8		148	398	25		146	490	31.1		146	643	40.7		148	773	48.3
5.6	3000	5.436	552	1064	17.9	5.436	—	—	—	5.504	—	—	—	5.489	—	—	—	5.775	—	—	—
	1500		276	553	18.6		276	773	26		273	947	32.2		273	1237	42		260	1478	52.7
	1000		184	375	18.9		184	525	26.4		182	645	32.9		182	845	43		173	1014	54.2
	750		138	284	19.1		138	398	26.7		136	490	33.3		137	643	43.6		130	773	55.1
6.3	3000	6.273	478	1064	20.6	6.273	—	—	—	6.346	—	—	—	6.329	—	—	—	6.188	—	—	—
	1500		239	553	21.4		239	773	30		236	947	37.1		237	1237	48.4		242	1478	56.5
	1000		159	375	21.8		159	525	30.5		158	645	37.9		158	845	49.6		162	1014	58.1
	750		120	284	22		120	398	30.8		118	490	38.4		119	643	50.3		121	773	59.1
7.1	3000	7.318	410	1064	24	7.318	—	—	—	6.842	—	—	—	7.379	—	—	—	7.158	—	—	—
	1500		205	553	25		205	773	35		219	947	40		203	1237	56.4		210	1478	65.3
	1000		137	375	25.4		137	525	35.6		146	645	40.9		136	845	57.8		140	1014	67.2
	750		103	284	25.7		103	398	36		110	490	41.4		102	643	58.6		105	773	68.3
8	3000	7.945	378	1064	26.1	7.945	—	—	—	8.031	—	—	—	8.01	—	—	—	7.734	—	—	—
	1500		189	553	27.1		189	773	38		187	947	47		187	1237	61.2		194	1478	70.6
	1000		126	375	27.6		126	525	38.6		125	645	48		125	845	62.7		129	1014	72.6
	750		94.4	284	27.9		94.4	398	39.1		93.4	490	48.6		93.6	643	63.6		97	773	73.8
9	3000	8.662	346	1022	27.3	8.662	—	—	—	8.753	—	—	—	8.73	—	—	—	9.134	—	—	—
	1500		173	520	27.8		173	773	41.4		171	947	51.2		172	1237	66.7		164	1478	83.4
	1000		115	351	28.1		115	525	42.1		114	645	52.3		115	845	68.4		110	1014	85.8
	750		86.6	265	28.4		86.6	398	42.6		85.7	490	53		85.9	643	69.3		82.1	773	87.2
10	3000	10.455	287	635	20.5	10.455	—	—	—	9.586	—	—	—	9.56	—	—	—	9.995	—	—	—
	1500		144	324	20.9		144	486	31.4		157	893	52.9		157	1234	72.9		150	1478	91.2
	1000		95.7	219	21.2		95.7	328	31.8		104	602	53.4		105	831	73.6		100	1014	93.9
	750		71.7	166	21.4		71.7	248	32		78.2	455	53.8		78.4	628	74.2		75	773	95.4
11.2	3000	11.595	259	458	16.4	11.595	—	—	—	11.706	—	—	—	11.675	—	—	—	11	—	—	—
	1500		129	234	16.8		129	358	25.6		128	498	36		129	679	49		136	1256	85.3
	1000		86.2	158	17		86.2	241	25.9		85.4	336	36.4		85.7	458	49.5		90.9	846	86.2
	750		64.7	120	17.2		64.7	183	26.1		64.1	254	36.7		64.2	346	49.9		68.2	639	86.9
12.5	3000	12.16	247	482	18.1	12.16	—	—	—	12.373	—	—	—	12.373	—	—	—	12	—	—	—
	1500		123	246	18.5		123	357	26.8		121	513	39.2		121	716	54.7		125	959	71.1
	1000		82.2	166	18.7		82.2	241	27.1		80.8	347	39.8		80.8	485	55.6		83.3	650	72.3
	750		61.7	126	18.9		61.7	182	27.3		60.6	263	40.2		60.6	368	56.2		62.5	493	73
14	3000	14.523	207	482	21.6	14.523	—	—	—	14.769	—	—	—	13.486	—	—	—	14.171	—	—	—
	1500		103	246	22.1		103	357	32		102	513	46.8		111	716	59.7		106	959	83.9
	1000		68.9	166	22.4		68.9	241	32.4		67.7	347	47.5		74.2	485	60.6		70.6	650	85.4
	750		51.6	126	22.5		51.6	182	32.6		50.8	263	48		55.6	368	61.2		52.9	493	86.2
16	3000	16	188	420	20.7	16	—	—	—	16.267	—	—	—	16.267	—	—	—	15.508	—	—	—
	1500		93.8	214	21.2		93.8	322	31.8		92.2	443	44.6		92.2	621	62.4		96.7	959	91.8
	1000		62.5	145	21.5		62.5	217	32.2		61.5	299	45.1		61.5	419	63.1		64.5	650	93.4
	750		46.9	110	21.7		46.9	164	32.5		46.1	226	45.5		46.1	317	63.7		48.4	493	94.4
18	3000	17.745	169	303	16.6	17.745	—	—	—	18.036	—	—	—	18.036	—	—	—	17.067	—	—	—
	1500		84.5	155	17		84.5	237	25.9		83.2	327	36.4		83.2	445	49.6		87.9	818	86.3
	1000		56.4	105	17.2		56.4	160	26.3		55.4	221	36.9		55.4	300	50.1		58.6	552	87.2
	750		42.3	79.6	17.4		42.3	121	26.5		41.6	167	37.2		41.6	227	50.6		43.9	417	88

Con lubrificazione forzata – *With forced lubrication*

Velocità non consentita – *Not allowed speed*



DATI TECNICI

TECHNICAL DATA

Riduttori ad assi ortogonali RHC/RVC tre stadi *RHC/RVC bevel-helical units - triple stage*

RHC RVC		70				80				90				100				110			
i_N	n_1 min ⁻¹	i	n_2 min ⁻¹	P_{N1} kW	T_{N2} kNm	i	n_2 min ⁻¹	P_{N1} kW	T_{N2} kNm	i	n_2 min ⁻¹	P_{N1} kW	T_{N2} kNm	i	n_2 min ⁻¹	P_{N1} kW	T_{N2} kNm	i	n_2 min ⁻¹	P_{N1} kW	T_{N2} kNm
20	3000	20.787	144	391	24.8	19.842	151	546	33	19.72	152	757	45.4	19.739	152	1064	63.9	19.842	–	–	–
	1500		72.2	200	25.3		75.6	283	34.2		76.1	393	47.2		76	553	66.4		75.6	773	93.4
	1000		48.1	135	25.6		50.4	192	34.7		50.7	266	47.9		50.7	375	67.5		50.4	525	95.1
	750		36.1	102	25.9		37.8	145	35		38	202	48.4		38	284	68.2		37.8	398	96.1
22.5	3000	22.3	135	366	24.8	22.775	132	539	37.3	22.517	133	757	51.9	22.678	132	1061	73.2	22.906	–	–	–
	1500		67.3	187	25.3		65.9	275	38.1		66.6	393	53.8		66.1	540	74.6		65.5	773	107.8
	1000		44.8	126	25.7		43.9	186	38.6		44.4	266	54.7		44.1	365	75.5		43.7	525	109.7
	750		33.6	95.7	26		32.9	141	39		33.3	202	55.2		33.1	277	76.3		32.7	398	110.9
25	3000	25.833	116	317	24.9	24.473	123	502	37.4	24.126	124	725	53.2	24.38	123	988	73.3	24.693	–	–	–
	1500		58.1	162	25.4		61.3	256	38.2		62.2	369	54.2		61.5	504	74.7		60.7	773	116.2
	1000		38.7	110	25.8		40.9	173	38.7		41.4	250	55		41	340	75.7		40.5	525	118.3
	750		29	83.1	26.1		30.6	131	39.1		31.1	189	55.5		30.8	258	76.5		30.4	398	119.6
28	3000	27.91	108	294	25	28.469	105	434	37.5	27.879	108	629	53.4	28.383	106	852	73.6	28.937	–	–	–
	1500		53.7	150	25.5		52.7	222	38.4		53.8	321	54.5		52.8	435	75.1		51.8	681	119.9
	1000		35.8	102	25.9		35.1	150	38.9		35.9	217	55.2		35.2	294	76.1		34.6	460	121.5
	750		26.9	77.1	26.2		26.3	114	39.3		26.9	165	55.8		26.4	223	76.9		25.9	349	122.8
31.5	3000	32.897	91.2	251	25.1	30.841	97.3	401	37.6	32.57	92.1	541	53.6	30.76	97.5	788	73.7	31.483	–	–	–
	1500		45.6	128	25.7		48.6	205	38.5		46.1	276	54.8		48.8	402	75.3		47.6	628	120.2
	1000		30.4	86.8	26.1		32.4	139	39		30.7	187	55.5		32.5	272	76.3		31.8	424	121.9
	750		22.8	65.9	26.4		24.3	105	39.5		23	142	56.2		24.4	206	77.2		23.8	322	123.2
35.5	3000	35.925	83.5	230	25.1	36.602	82	340	37.8	35.385	84.8	499	53.7	36.533	82.1	667	74.1	34.393	–	–	–
	1500		41.8	118	25.7		41	174	38.7		42.4	255	54.9		41.1	341	75.7		43.6	576	120.6
	1000		27.8	79.8	26.1		27.3	118	39.3		28.3	173	55.7		27.4	230	76.8		29.1	390	122.3
	750		20.9	60.5	26.5		20.5	89.3	39.8		21.2	131	56.4		20.5	175	77.7		21.8	295	123.6
40	3000	39.418	76.1	210	25.2	40.148	74.7	311	37.9	38.601	77.7	459	53.9	40.086	74.8	609	74.3	41.669	–	–	–
	1500		38.1	108	25.8		37.4	159	38.8		38.9	235	55.1		37.4	311	76		36	479	121.3
	1000		25.4	73	26.2		24.9	108	39.4		25.9	159	55.9		24.9	211	77.1		24	324	123.1
	750		19	55.4	26.6		18.7	81.7	39.9		19.4	120	56.6		18.7	160	78		18	245	124.2
45	3000	43.494	69	191	25.3	44.284	67.7	282	38	42.313	70.9	420	54	44.231	67.8	554	74.5	46.299	–	–	–
	1500		34.5	98	25.9		33.9	145	39		35.5	215	55.3		33.9	283	76.2		32.4	411	115.7
	1000		23	66.4	26.4		22.6	98	39.6		23.6	145	56.1		22.6	192	77.4		21.6	277	116.9
	750		17.2	50.4	26.7		16.9	74.4	40.1		17.7	110	56.8		17	146	78.3		16.2	209	117.9
50	3000	50.347	59.6	166	25.4	51.315	58.5	237	37	54.154	55.4	330	54.4	51.2	58.6	481	74.8	52.637	57	694	111.2
	1500		29.8	85.1	26.1		29.2	121	37.8		27.7	169	55.8		29.3	246	76.6		28.5	357	114.3
	1000		19.9	57.7	26.5		19.5	81.7	38.3		18.5	115	56.7		19.5	166	77.6		19	241	115.6
	750		14.9	43.8	26.8		14.6	61.8	38.6		13.8	87.1	57.4		14.6	126	78.3		14.2	182	116.5
56	3000	54.98	54.6	153	25.5	56.018	53.6	225	38.3	59.077	50.8	304	54.6	55.912	53.7	441	75	57.776	51.9	682	119.9
	1500		27.3	78.2	26.2		26.8	115	39.3		25.4	156	56		26.8	226	76.9		26	349	122.8
	1000		18.2	53	26.6		17.9	78.2	40		16.9	106	56.9		17.9	153	78.1		17.3	236	124.3
	750		13.6	40.3	27		13.4	59.4	40.5		12.7	80.1	57.6		13.4	116	79		13	178	125
63	3000	60.327	49.7	139	25.6	61.444	48.8	206	38.5	64.757	46.3	278	54.7	61.349	48.9	403	75.3	63.771	47	620	120.3
	1500		24.9	71.6	26.3		24.4	106	39.5		23.2	143	56.2		24.5	207	77.2		23.5	318	123.2
	1000		16.6	48.5	26.7		16.3	71.6	40.1		15.4	96.6	57.1		16.3	140	78.4		15.7	214	124.6
	750		12.4	36.9	27.1		12.2	54.4	40.6		11.6	73.4	57.8		12.2	106	79.3		11.8	162	125.3
71	3000	73.936	40.6	115	25.8	67.774	44.3	187	38.6	71.385	42	253	54.9	67.692	44.3	367	75.5	70.857	42.3	533	114.9
	1500		20.3	58.9	26.5		22.1	96.1	39.6		21	130	56.4		22.2	188	77.4		21.2	271	117
	1000		13.5	40	27		14.8	65.2	40.3		14	88	57.3		14.8	127	78.7		14.1	183	118.4
	750		10.1	30.4	27.3		11.1	49.5	40.8		10.5	66.8	58.1		11.1	96.7	79.7		10.6	139	119.6
80	3000	82.782	36.2	94.8	23.9	75.256	39.9	169	38.7	79.217	37.9	229	55.1	75.189	39.9	331	75.8	79.36	37.8	375	90.6
	1500		18.1	48.6	24.5		19.9	86.9	39.8		18.9	117	56.5		19.9	170	77.8		18.9	191	92.3
	1000		12.1	32.9	24.9		13.3	59	40.5		12.6	79.3	57.3		13.3	115	79.1		12.6	129	93.5
	750		9.1	25	25.2		10	44.8	41		9.5	60.1	58		10	87.5	80		9.5	97.8	94.4

Con lubrificazione forzata – *With forced lubrication*

Velocità non consentita – *Not allowed speed*



DATI TECNICI

TECHNICAL DATA

Riduttori ad assi ortogonali
RHD/RVD quattro stadi

RHD/RVD bevel-helical units - quadruple stage

RHD RVD		10			20			30			40			50			60													
i _N	n ₁ min ⁻¹	i	n ₂ min ⁻¹	P _{N1} kW	T _{N2} kNm	i	n ₂ min ⁻¹	P _{N1} kW	T _{N2} kNm	i	n ₂ min ⁻¹	P _{N1} kW	T _{N2} kNm	i	n ₂ min ⁻¹	P _{N1} kW	T _{N2} kNm	i	n ₂ min ⁻¹	P _{N1} kW	T _{N2} kNm									
80	3000	77.926	38.5	13.2	3.1	88.569				78.361	38.3	28	6.6	90.472				87.126				88.125								
	1500		19.2	6.8	3.2		19.1	14.5	6.8																					
	1000		12.8	4.7	3.3		11.3	6.1	4.9		11.2	8.7	7		11.1	11.9	9.7		11.5	10.1	15.7		11.3	26.7	21.2					
	750		9.6	3.5	3.3		8.5	4.6	4.9		8.4	6.6	7.1		8.3	9.1	9.8		8.6	15.3	15.9		8.5	20.3	21.4					
90	3000	88.964	33.7	11.7	3.1	101.85	33.9	17.3	4.6	102.17	33.6	24.8	6.6	103.94	33.2	33.8	9.2	100.01	34.4	57.4	15	100.63	34	76.5	20.2					
	1500		16.9	6	3.2		16.8	12.8	6.8		16.6	17.5	9.5		17.2	29.6	15.4		17	39.4	20.8									
	1000		11.2	4.1	3.3		11.3	6.1	4.9		11.2	8.7	7		11.1	11.9	9.7		11.5	10.1	15.7		11.3	26.7	21.2					
	750		8.4	3.1	3.3		8.5	4.6	4.9		8.4	6.6	7.1		8.3	9.1	9.8		8.6	15.3	15.9		8.5	20.3	21.4					
100	3000	102.21	29.4	10.2	3.1	109.55	29.5	15.2	4.6	109.61	29.4	21.8	6.7	111.74	28.9	29.6	9.2	115.75	30	50.3	15.1	115.76	29.8	67.3	20.3					
	1500		14.7	5.3	3.2		14.7	7.9	4.8		14.4	15.3	9.5		15	25.9	15.5		14.9	34.7	20.9									
	1000		9.8	3.6	3.3		9.8	5.3	4.9		9.6	10.4	9.7		9.6	10.4	9.7		10	17.6	15.8		9.9	23.5	21.3					
	750		7.3	2.7	3.4		7.4	4.1	5		7.3	5.8	7.1		7.2	7.9	9.9		7.5	13.4	16		7.5	17.9	21.6					
112	3000	109.88	27.3	9.5	3.1	127.64	27.4	14.2	4.6	126.97	27.4	20.3	6.7	120.41	26.8	27.6	9.3	125.01	25.9	43.7	15.2	124.58	25.9	58.9	20.4					
	1500		13.7	4.9	3.2		13.7	7.3	4.8		13.4	14.3	9.6		13.4	22.5	15.6		13	30.3	21									
	1000		9.1	3.4	3.3		9.1	5	4.9		8.9	9.7	9.8		8.6	15.3	15.9		8.6	20.6	21.4									
	750		6.8	2.6	3.4		6.8	3.8	5		6.8	5.5	7.2		6.7	7.5	10		6.5	11.8	16.4		6.5	15.9	22					
125	3000	127.92	23.5	8.3	3.2	138.39	23.5	12.2	4.7	137.19	23.6	17.7	6.7	140.99	24.9	25.7	9.3	135.42	24	40.6	15.2	145.55	24.1	54.9	20.5					
	1500		11.7	4.3	3.3		11.8	6.3	4.8		12.5	13.3	9.6		12	20.9	15.7		12	28.3	21.1									
	1000		7.8	2.9	3.3		7.8	4.3	5		7.9	6.2	7.1		8.3	9.1	9.8		8	14.2	16		8	19.2	21.5					
	750		5.9	2.3	3.5		5.9	3.4	5.2		5.9	4.9	7.4		6.2	7	10.1		6	11.1	16.6		6	14.9	22.3					
140	3000	138.64	21.6	7.6	3.2	164.49	21.7	11.3	4.7	161.7	21.9	16.4	6.8	153.33	21.3	22.1	9.4	160.72	22.2	37.6	15.3	158.13	20.6	47.3	20.6					
	1500		10.8	4	3.3		10.8	5.9	4.9		10.6	11.5	9.7		11.1	19.4	15.7		10.3	24.4	21.3									
	1000		7.2	2.7	3.4		7.2	4	5		7.3	5.8	7.1		7.1	7.8	9.9		7.4	13.2	16.1		6.9	16.7	21.8					
	750		5.4	2.1	3.5		5.4	3.2	5.2		5.5	4.6	7.5		5.3	6.2	10.4		5.5	10.3	16.7		5.2	12.9	22.5					
160	3000	164.65	18.2	6.5	3.2	180.54	18.2	9.6	4.7	176.58	18.6	14.1	6.8	183.73	19.6	20.4	9.4	176.29	18.7	31.9	15.4	172.5	19	43.7	20.7					
	1500		9.1	3.4	3.3		9.1	5	4.9		9.3	7.3	7.1		9.8	10.6	9.7		9.3	16.5	15.9		9.5	22.5	21.3					
	1000		6.1	2.3	3.5		6.1	3.5	5.1		6.2	5.1	7.3		6.5	7.3	10.1		6.2	11.4	16.5		6.3	15.6	22.1					
	750		4.6	1.9	3.7		4.6	2.7	5.4		4.6	4	7.7		4.9	5.8	10.6		4.7	8.8	16.9		4.7	11.9	22.6					
180	3000	180.67	16.6	5.9	3.2	199.28	16.6	8.8	4.8	193.75	17	12.9	6.8	202.72	16.3	17.2	9.5	194.46	17	29.2	15.4	208.44	17.4	40.2	20.8					
	1500		8.3	3.1	3.3		8.3	4.6	4.9		8.5	6.7	7.1		8.2	8.9	9.8		8.5	15.1	15.9		8.7	20.7	21.4					
	1000		5.5	2.2	3.5		5.5	3.2	5.2		5.7	4.7	7.5		5.4	6.3	10.4		5.7	10.5	16.7		5.8	14.5	22.4					
	750		4.2	1.7	3.7		4.2	2.5	5.5		4.2	3.7	7.8		4.1	4.9	10.9		4.3	8	17		4.3	10.9	22.6					
200	3000	199.35	15	5.4	3.2	230.43	15.1	8	4.8	227.54	15.5	11.8	6.9	234.67	14.8	15.7	9.5	225.33	15.4	26.6	15.5	222.75	14.4	33.5	20.9					
	1500		7.5	2.8	3.4		7.5	4.2	5		7.7	6.1	7.1		7.4	8.1	9.9		7.7	13.7	16		7.2	17.4	21.7					
	1000		5	2	3.6		5	3	5.3		5.2	4.4	7.6		4.9	5.8	10.6		5.1	9.6	16.8		4.8	12	22.6					
	750		3.8	1.6	3.8		3.8	2.3	5.6		3.9	3.4	8		3.7	4.5	11		3.9	7.3	17.1		3.6	9.1	22.7					
225	3000	230.76	13	4.7	3.3	251.73	13	7	4.8	247.47	13.2	10.2	6.9	256.26	12.8	13.6	9.6	245.98	13.3	23.1	15.6	242	13.5	31.5	21					
	1500		6.5	2.5	3.4		6.5	3.7	5.1		6.6	5.3	7.3		6.4	7.2	10.1		6.7	12.1	16.3		6.7	16.4	21.9					
	1000		4.3	1.8	3.7		4.3	2.6	5.5		4.4	3.8	7.8		4.3	5.1	10.8		4.4	8.4	16.9		4.5	11.3	22.6					
	750		3.3	1.4	3.9		3.3	2.1	5.7		3.3	3	8.2		3.2	4	11.3		3.3	6.4	17.2		3.4	8.5	22.7					
250	3000	251.99	11.9	4.3	3.3	276.31	11.9	6.4	4.8	270.24	12.1	9.4	7	281.18	11.7	12.6	9.6	269.8	12.2	21.3	15.7	289.38	12.4	29.1	21.1					
	1500		6	2.3	3.5		6	3.4	5.2		6.1	5	7.4		5.9	6.7	10.3		6.1	11.2	16.6		6.2	15.3	22.2					
	1000		4	1.7	3.7		4	2.5	5.5		4	3.6	7.9		3.9	4.8	11		4.1	7.7	17		4.1	10.4	22.6					
	750		3	1.3	3.9		3	1.9	5.8		3	2.8	8.3		2.9	3.7	11.5		3	5.9	17.3		3.1	7.8	22.8					
280	3000	276.5	10.9	4	3.3	304.99	10.9	5.9	4.9	327.18	11.1	8.6	7	310.26	10.7	11.5	9.7	297.6	11.1	19.5	15.7	319	10.4	24.5	21.2					
	1500		5.4	2.1	3.5		5.4	3.2	5.2		5.6	4.6	7.5		5.3	6.2	10.4		5.6	10.3	16.7		5.2	13	22.5					
	1000		3.6	1.5	3.8		3.6	2.3	5.6		3.7	3.3	8		3.6	4.4	11.1		3.7	7.1	17.1		3.5	8.7	22.7					
	750		2.7	1.2	4		2.7	1.8	5.9		2.8	2.6	8.4		2.7	3.4	11.6		2.8	5.4	17.4		2.6	6.6	22.8					
315	3000	305.08	9.8	3.6	3.3	338.87	9.8	5.4	4.9	363.41	9.2	7.2	7.1	344.62	9.7	10.5	9.7	330.45	10.1	17.7	15.8	354	9.4	22.3	21.3					
	1500		4.9	2	3.6		4.9	2.9	5.3		4.6	3.9	7.7		4.8	5.7	10.6		5	9.4	16.8		4.7	11.8	22.6					
	1000		3.3	1.4	3.9		3.3	2.1	5.7		3.1	2.8	8.3		3.2	4	11.3		3.4	6.4	17.2		3.1	7.9	22.7					
	750		2.5	1.1	4		2.5	1.6	6		2.3	2.2	8.6		2.4	3.1	11.6		2.5	4.9	17.5		2.4	6	22.9					
355	3000	338.87	8.9	3.3	3.3	388.87	8.9	4.8	4.9	413.41	8.3	6.5	7.1	444.62	8.7	9.5	9.8	430.45	9.1	16	15.9	454	8.5	20.2	21.4					
	1500		4.4	1.8	3.7		4.4	2.7	5.4		4.1																			



DATI TECNICI

TECHNICAL DATA

Riduttori ad assi ortogonali
RHD/RVD quattro stadi

RHD/RVD bevel-helical units - quadruple stage

RHD RVD		70				80				90				100				110								
i_N	n_1 min ⁻¹	i	n_2 min ⁻¹	P_{N1} kW	T_{N2} kNm	i	n_2 min ⁻¹	P_{N1} kW	T_{N2} kNm	i	n_2 min ⁻¹	P_{N1} kW	T_{N2} kNm	i	n_2 min ⁻¹	P_{N1} kW	T_{N2} kNm	i	n_2 min ⁻¹	P_{N1} kW	T_{N2} kNm					
80	3000																									
	1500																									
	1000																									
	750																									
90	3000	88.964	33.7	97.4	26	88.569	33.9	147	39	89.231	33.6	207	55.4	90.472	33.2	281	76.3	87.126	34.4	466	121.5					
	1500		16.9	50.1	26.7		16.9	75.5	40.1		16.8	106	56.9		16.6	145	78.4		17.2	238	124.3					
	1000		11.2	34	27.2		11.3	51.2	40.8		11.2	72.2	57.9		11.1	98	79.7		11.5	160	125.3					
	750		8.4	25.8	27.6		8.5	38.9	41.3		8.4	54.8	58.7		8.3	74.4	80.7		8.6	121	126.1					
100	3000	102.21	29.4	85.2	26.1	101.85	29.5	128	39.2	102.17	29.4	182	55.6	103.94	28.9	246	76.7	100.01	30	408	122.1					
	1500		14.7	43.9	26.9		14.7	66	40.3		14.7	93.4	57.2		14.4	127	78.8		15	208	124.7					
	1000		9.8	29.8	27.4		9.8	44.8	41		9.8	63.4	58.3		9.6	85.8	80.2		10	140	125.7					
	750		7.3	22.6	27.7		7.4	34.1	41.6		7.3	48.2	59		7.2	65.2	81.2		7.5	106	126.4					
112	3000	109.88	27.3	79.5	26.2	109.55	27.4	120	39.3	109.61	27.4	170	55.8	111.74	26.8	230	76.9	107.46	27.9	380	122.4					
	1500		13.7	40.9	26.9		13.7	61.6	40.4		13.7	87.4	57.4		13.4	118	79		14	194	124.9					
	1000		9.1	27.8	27.5		9.1	41.8	41.2		9.1	59.3	58.4		8.9	80.1	80.4		9.3	130	125.9					
	750		6.8	21.3	28		6.8	32	42.1		6.8	45.3	59.6		6.7	61.3	82		7	98.3	126.6					
125	3000	127.92	23.5	68.7	26.3	127.64	23.5	103	39.5	126.97	23.6	148	56.1	120.41	24.9	214	77.1	125.01	24	329	123.1					
	1500		11.7	35.4	27.1		11.8	53.2	40.7		11.8	75.9	57.8		12.5	110	79.3		12	167	125.2					
	1000		7.8	24	27.6		7.8	36.2	41.5		7.9	51.5	58.8		8.3	74.5	80.7		8	112	126.2					
	750		5.9	18.7	28.7		5.9	28.1	43		5.9	40	60.9		6.2	57.5	82.9		6	84.7	127					
140	3000	138.64	21.6	63.6	26.4	138.39	21.7	95.6	39.7	137.19	21.9	137	56.3	140.99	21.3	184	77.6	135.42	22.2	304	123.5					
	1500		10.8	32.8	27.2		10.8	49.3	40.9		10.9	70.5	58		10.6	94.5	79.8		11.1	155	125.4					
	1000		7.2	22.3	27.8		7.2	33.5	41.7		7.3	47.9	59		7.1	64.2	81.4		7.4	104	126.4					
	750		5.4	17.5	29.1		5.4	26.3	43.6		5.5	37.5	61.6		5.3	50.2	84.9		5.5	78.3	127.2					
160	3000	164.65	18.2	53.9	26.6	164.49	18.2	81	39.9	161.7	18.6	117	56.7	153.33	19.6	169	77.8	160.72	18.7	258	124.1					
	1500		9.1	27.8	27.5		9.1	41.8	41.2		9.3	60.3	58.4		9.8	87.2	80.1		9.3	131	125.9					
	1000		6.1	19.3	28.5		6.1	29	42.8		6.2	41.6	60.5		6.5	59.8	82.4		6.2	87.8	126.9					
	750		4.6	15.1	29.9		4.6	22.7	44.8		4.6	32.6	63.2		4.9	46.8	85.9		4.7	66.2	127.6					
180	3000	180.67	16.6	49.4	26.7	180.54	16.6	74.1	40.1	176.58	17	108	56.9	183.73	16.3	142	78.4	176.29	17	235	124.3					
	1500		8.3	25.5	27.6		8.3	38.2	41.4		8.5	55.4	58.6		8.2	73.3	80.7		8.5	119	126.1					
	1000		5.5	17.8	29		5.5	26.8	43.4		5.7	38.6	61.3		5.4	51.2	84.6		5.7	80.2	127.1					
	750		4.2	14	30.3		4.2	20.9	45.3		4.2	30.3	64.1		4.1	39.8	87.7		4.3	60.5	127.8					
200	3000	199.35	15	44.9	26.8	199.28	15.1	67.4	40.3	193.75	15.5	98.3	57.1	202.72	14.8	130	78.7	194.46	15.4	214	124.6					
	1500		7.5	23.2	27.7		7.5	34.8	41.6		7.7	50.7	58.9		7.4	66.7	81.1		7.7	108	126.3					
	1000		5	16.4	29.4		5	24.6	44.1		5.2	35.7	62.2		4.9	47.1	85.8		5.1	72.9	127.3					
	750		3.8	12.9	30.8		3.8	19	45.4		3.9	27.9	64.7		3.7	36.2	87.9		3.9	54.9	128.1					
225	3000	230.76	13	39.1	27	221.42	13.5	61	40.5	227.54	13.2	84.3	57.5	234.67	12.8	113	79.2	225.33	13.3	185	125					
	1500		6.5	20.4	28.3		6.8	31.7	42.1		6.6	43.9	59.9		6.4	58.8	82.6		6.7	93.8	126.7					
	1000		4.3	14.5	30.1		4.5	22.5	44.8		4.4	31.2	63.7		4.3	41.5	87.6		4.4	63.1	127.7					
	750		3.3	11.2	31		3.4	17.1	45.5		3.3	23.8	64.9		3.2	31.3	88.1		3.3	47.6	128.4					
250	3000	251.99	11.9	35.9	27.1	251.73	11.9	53.9	40.7	270.24	11.1	71.5	57.9	256.26	11.7	104	79.5	245.98	12.2	170	125.2					
	1500		6	19	28.6		6	28.5	43		5.6	38	61.5		5.9	54.5	83.7		6.1	86.1	126.9					
	1000		4	13.5	30.5		4	20	45.4		3.7	26.7	64.8		3.9	38.1	87.8		4.1	57.9	127.9					
	750		3	10.3	31.1		3	15.1	45.6		2.8	20.1	65.1		2.9	28.7	88.3		3	43.6	128.7					
280	3000	276.5	10.9	32.9	27.2	276.31	10.9	49.4	40.9	296.52	10.1	65.5	58.2	281.18	10.7	94.7	79.8	269.8	11.1	155	125.4					
	1500		5.4	17.5	29.1		5.4	26.3	43.6		5.1	35.1	62.4		5.3	50.3	84.8		5.6	78.6	127.2					
	1000		3.6	12.4	30.9		3.6	18.3	45.4		3.4	24.3	64.9		3.6	34.8	87.9		3.7	52.8	128.2					
	750		2.7	9.4	31.1		2.7	13.8	45.7		2.5	18.4	65.3		2.7	26.2	88.4		2.8	39.9	128.9					
315	3000	305.08	9.8	29.9	27.4	304.99	9.8	44.9	41	327.18	9.2	59.6	58.4	310.26	9.7	86.2	80.1	330.45	9.1	127	125.9					
	1500		4.9	16.1	29.5		4.9	24.2	44.2		4.6	32.3	63.3		4.8	46.3	86.1		4.5	64.5	127.7					
	1000		3.3	11.3	31		3.3	16.6	45.5		3.1	22.1	65		3.2	31.6	88.1		3	43.3	128.7					
	750		2.5	8.5	31.2		2.5	12.5	45.8		2.3	16.7	65.4		2.4	23.8	88.6		2.3	32.7	129.4					
355	3000	338.87	8.9	27.1	27.5	379.54	7.9	36.5	41.5	363.41	8.3	53.9	58.7	344.62	8.7	78	80.5	369.87	8.1	114	126.2					
	1500		4.4	14.8	30		4	19.9	45.4		4.1	29.5	64.3		4.4	42.3	87.4		4.1	57.7	127.9					
	1000		3	10.2	31.1		2.6	13.4	45.7		2.8	19.9	65.2		2.9	28.5	88.3		2.7	38.8	129					
	750		2.2	7.7	31.2		2	10.1	46		2.1	15	65.5		2.2	21.5	88.8		2	29.3	129.7					
400	3000	379.42	7.9	24.3	27.6					406.89	7.4	48.4	59	385.85	7.8	70	80.9									
	1500		4	13.4	30.5						3.7	26.6	64.8			3.9	38	87.8								
	1000		2.6	9.1	31.1						2.5	17.9	65.3			2.6	25.5	88.5								



DIMENSIONI

Riduttori ad assi ortogonali
PA singolo stadio

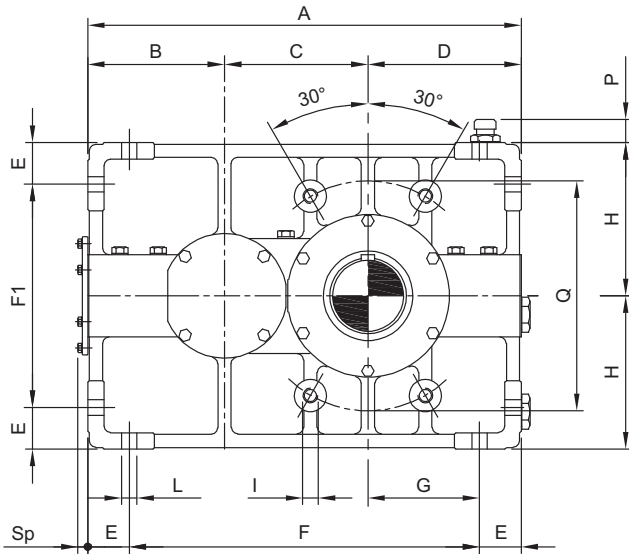

DIMENSIONAL DATA

PA helical units - single stage

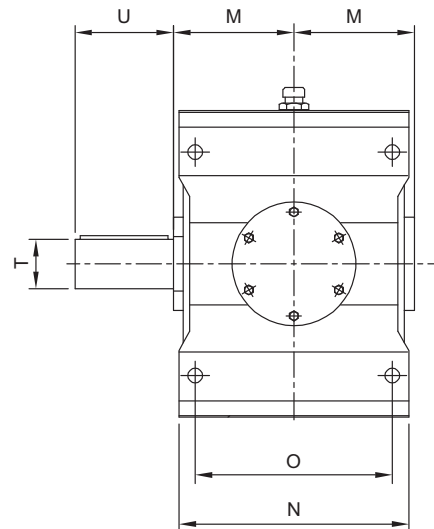
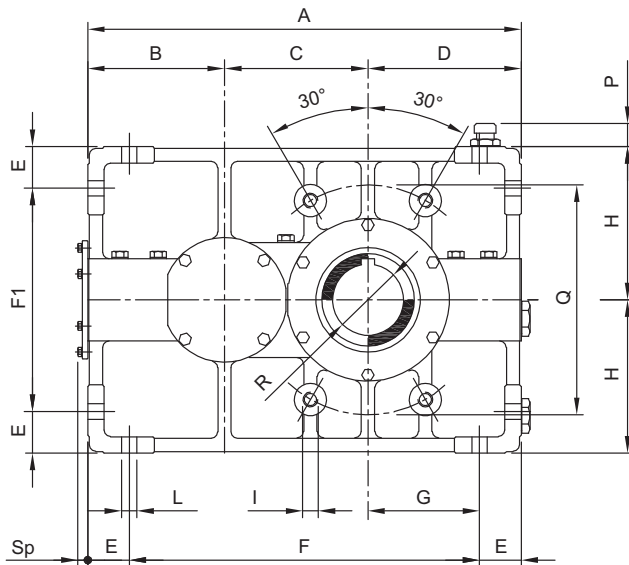
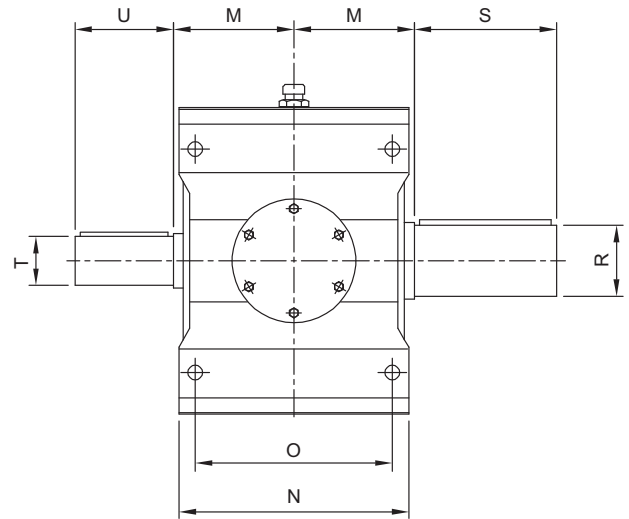

																		$i_N \leq 2.5$		$i_N \geq 2.8$		Sp	
	A	B	C	D	E	F	F1	G	H	I	L	M	N	O	P	Q	R	S	T	U	T		U
10	396	125	131	140	38	320	204	102	140	M16	14	115	210	180	20	210	65	110	45	90	35	70	13
20	450	140	150	160	42	366	236	118	160	M18	16	135	235	200	22	240	80	140	50	100	40	80	16
30	510	160	170	180	46	418	268	134	180	M20	18	145	260	220	22	270	90	160	55	110	45	90	17
40	570	180	190	200	52	466	296	148	200	M22	20	160	295	250	22	300	100	180	70	140	55	110	18
50	641	200	216	225	57	527	336	168	225	M24	22	170	325	275	22	340	110	200	75	150	60	120	22
60	715	225	240	250	62	591	376	188	250	M27	25	190	360	300	22	380	120	210	85	170	70	140	23
70	792	250	262	280	72	648	416	208	280	M30	27	225	415	350	25	430	140	250	90	180	80	160	25
80	895	280	300	315	80	735	470	235	315	M33	30	250	455	385	25	490	160	280	100	200	85	170	26
90	1010	315	340	355	87	836	536	268	355	M36	33	280	535	460	25	560	170	300	130	260	100	200	29
100	1135	355	380	400	93	949	614	307	400	M39	36	310	600	520	25	640	200	350	150	300	110	220	30
110	1282	400	432	450	100	1082	700	350	450	M42	39	375	710	620	25	730	220	390	160	320	130	260	32



DIMENSIONI

Riduttori ad assi paralleli
PB due stadi

DIMENSIONAL DATA

PB helical units - double stage

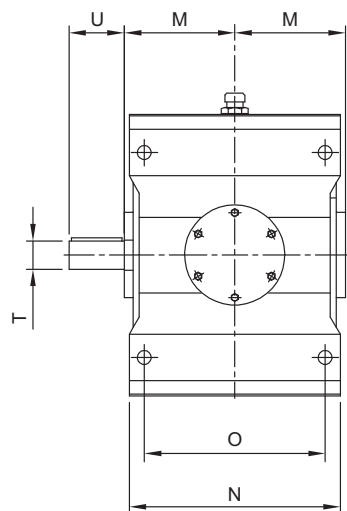
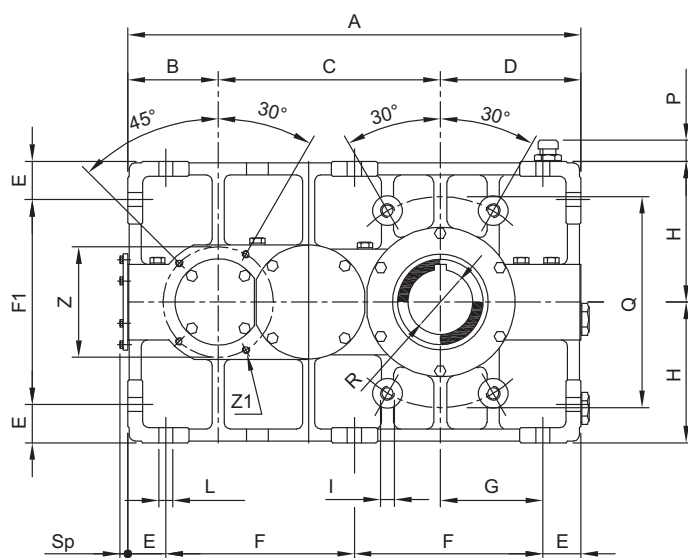
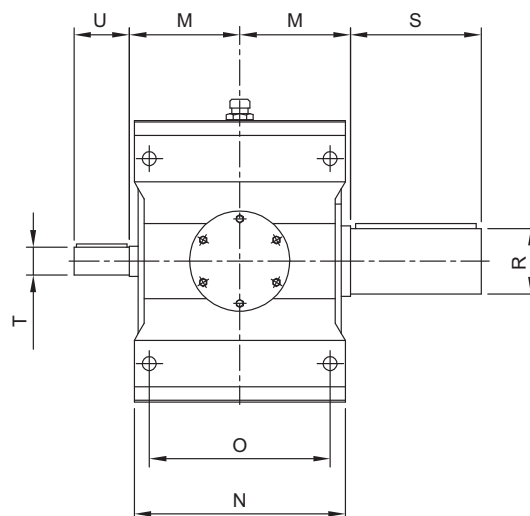
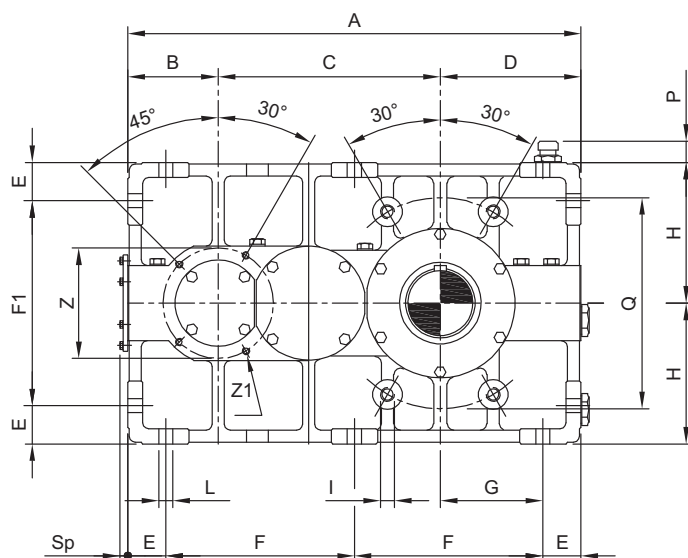

																				$i_N \leq 11.2$		$i_N \geq 12.5$		Z	Z1	Sp
	A	B	C	D	E	F	F1	G	H	I	L	M	N	O	P	Q	R	S	T	U	T	U				
10	451	90	221	140	38	187.5	204	102	140	M16	14	115	210	180	20	210	65	110	28	55	24	50	110	M8	11	
20	510	100	250	160	42	213	236	118	160	M18	16	135	235	200	22	240	80	140	32	65	28	55	125	M10	11	
30	574	112	282	180	46	241	268	134	180	M20	18	145	260	220	22	270	90	160	35	70	32	65	140	M12	12	
40	640	125	315	200	52	268	296	148	200	M22	20	160	295	250	22	300	100	180	45	90	35	70	160	M14	13	
50	721	140	356	225	57	303.5	336	168	225	M24	22	170	325	275	22	340	110	200	50	100	40	80	175	M16	16	
60	810	160	400	250	62	343	376	188	250	M27	25	190	360	300	22	380	120	210	55	110	45	90	200	M16	17	
70	902	180	442	280	72	379	416	208	280	M30	27	225	415	350	25	430	140	250	70	140	55	110	220	M18	18	
80	1015	200	500	315	80	427.5	470	235	315	M33	30	250	455	385	25	490	160	280	75	150	60	120	250	M20	22	
90	1145	225	565	355	87	485.5	536	268	355	M36	33	280	535	460	25	560	170	300	85	170	70	140	275	M22	23	
100	1280	250	630	400	93	547	614	307	400	M39	36	310	600	520	25	640	200	350	90	180	80	160	310	M24	25	
110	1442	280	712	450	100	621	700	350	450	M42	39	375	710	620	25	730	220	390	100	200	85	170	350	M27	26	



DIMENSIONI

Riduttori ad assi paralleli
PC tre stadi

DIMENSIONAL DATA

PC helical units - triple stage

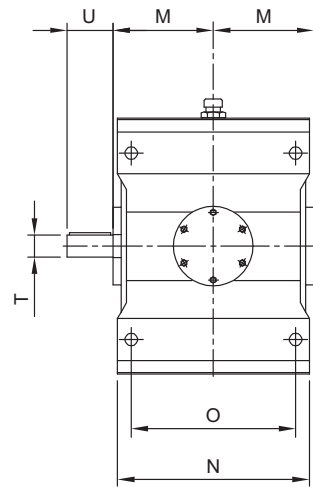
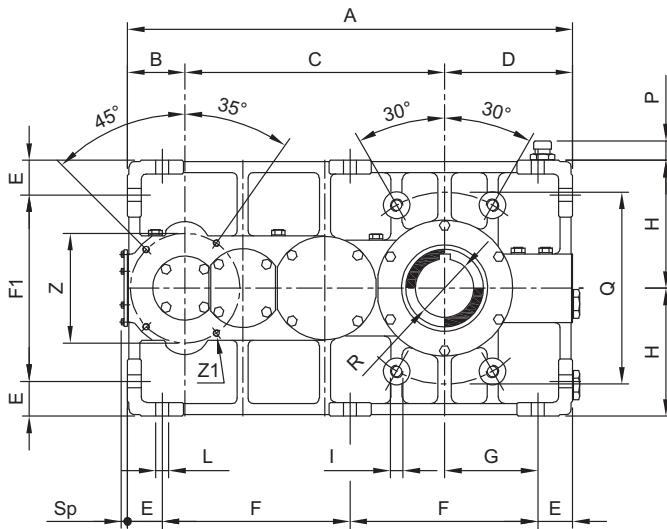
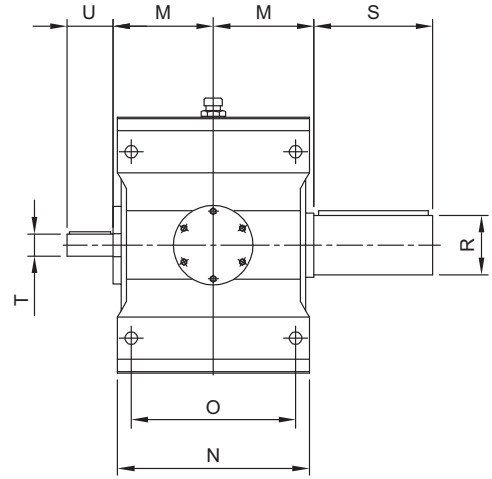
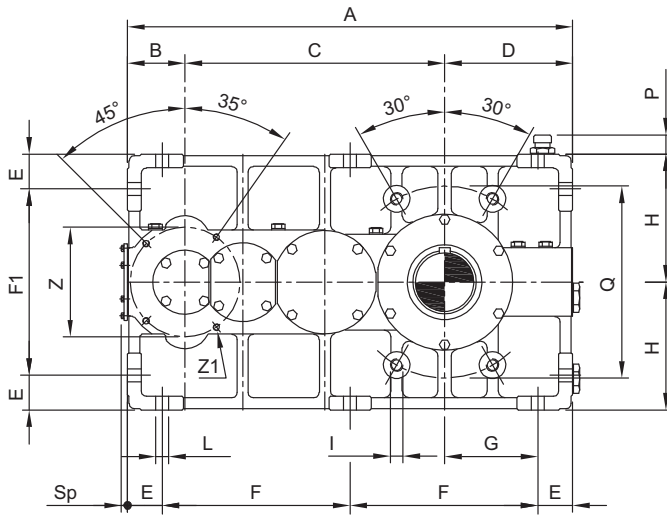

	A	B	C	D	E	F	F1	G	H	I	L	M	N	O	P	Q	R	S	T	U	Z	Z1	Sp
10	487	63	284	140	38	205.5	204	102	140	M16	14	115	210	180	20	210	65	110	24	50	120	M8	10
20	550	70	320	160	42	233	236	118	160	M18	16	135	235	200	22	240	80	140	24	50	130	M10	10
30	622	80	362	180	46	265	268	134	180	M20	18	145	260	220	22	270	90	160	28	55	150	M12	11
40	695	90	405	200	52	295.5	296	148	200	M22	20	160	295	250	22	300	100	180	30	60	170	M12	11
50	781	100	456	225	57	333.5	336	168	225	M24	22	170	325	275	22	340	110	200	32	65	185	M12	11
60	874	112	512	250	62	375	376	188	250	M27	25	190	360	300	22	380	120	210	40	80	210	M14	12
70	972	125	567	280	72	414	416	208	280	M30	27	225	415	350	25	430	140	250	45	90	235	M14	13
80	1095	140	640	315	80	467.5	470	235	315	M33	30	250	455	385	25	490	160	280	50	100	260	M16	16
90	1240	160	725	355	87	533	536	268	355	M36	33	280	535	460	25	560	170	300	55	110	290	M16	17
100	1390	180	810	400	93	602	614	307	400	M39	36	310	600	520	25	640	200	350	70	140	320	M18	18
110	1562	200	912	450	100	681	700	350	450	M42	39	375	710	620	25	730	220	390	75	150	350	M18	22



DIMENSIONI

Riduttori ad assi paralleli
PD quattro stadi

DIMENSIONAL DATA

PD helical units - quadruple stage

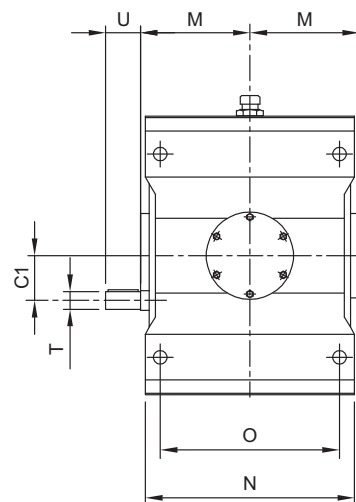
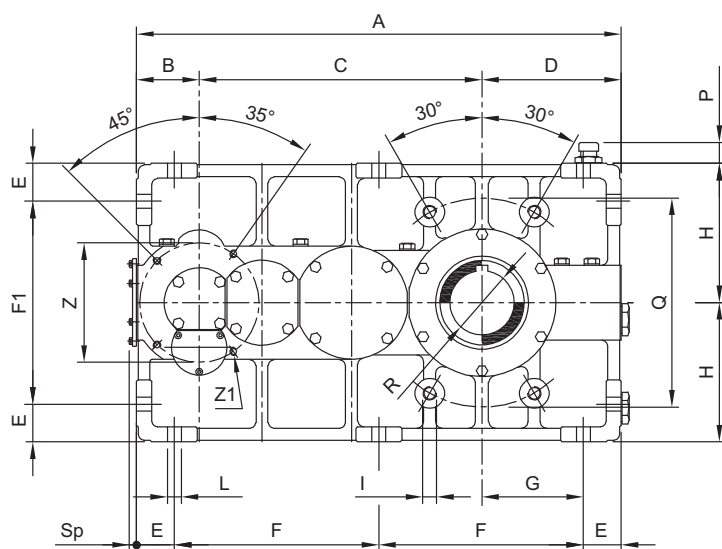
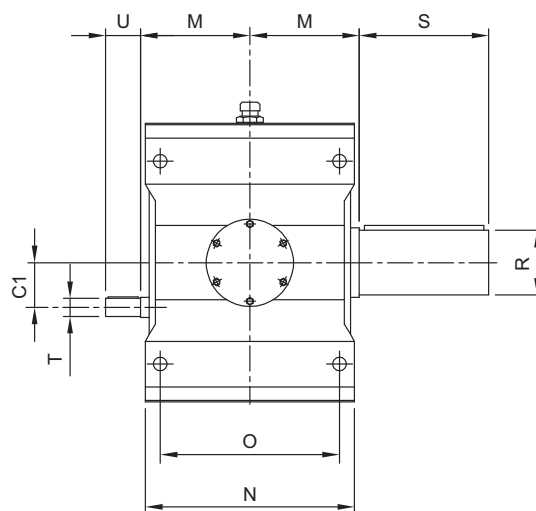
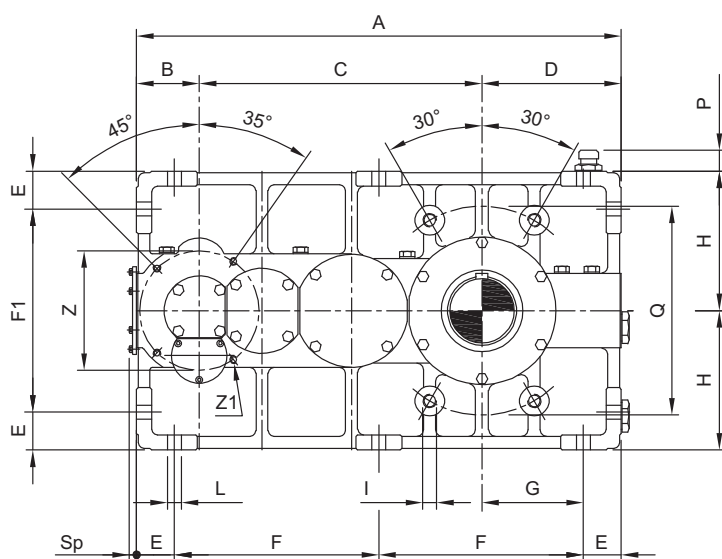

	A	B	C	C1	D	E	F	F1	G	H	I	L	M	N	O	P	Q	R	S	T	U	Z	Z1	Sp
10	487	63	284	45	140	38	205.5	204	102	140	M16	14	115	210	180	20	210	65	110	18	35	120	M8	10
20	550	70	320	50	160	42	233	236	118	160	M18	16	135	235	200	22	240	80	140	18	35	130	M10	10
30	622	80	362	56	180	46	265	268	134	180	M20	18	145	260	220	22	270	90	160	24	50	150	M12	11
40	695	90	405	63	200	52	295.5	296	148	200	M22	20	160	295	250	22	300	100	180	24	50	170	M12	11
50	781	100	456	70	225	57	335.5	336	168	225	M24	22	170	325	275	22	340	110	200	24	50	185	M12	11
60	874	112	512	80	250	62	375	376	188	250	M27	25	190	360	300	22	380	120	210	28	55	210	M14	12
70	972	125	567	90	280	72	414	416	208	280	M30	27	225	415	350	25	430	140	250	28	55	235	M14	13
80	1095	140	640	100	315	80	467.5	470	235	315	M33	30	250	455	385	25	490	160	280	32	65	260	M16	16
90	1240	160	725	112	355	87	533	536	268	355	M36	33	280	535	460	25	560	170	300	35	70	290	M16	17
100	1390	180	810	125	400	93	602	614	307	400	M39	36	310	600	520	25	640	200	350	45	90	320	M18	18
110	1562	200	912	140	450	100	681	700	350	450	M42	39	375	710	620	25	730	220	390	50	100	350	M18	22



DIMENSIONI

Riduttori ad assi ortogonali
RHB due stadi

DIMENSIONAL DATA

RHB bevel-helical units - double stage

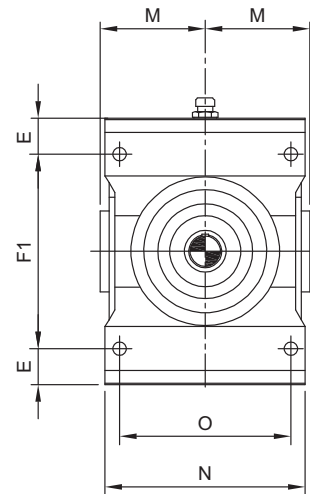
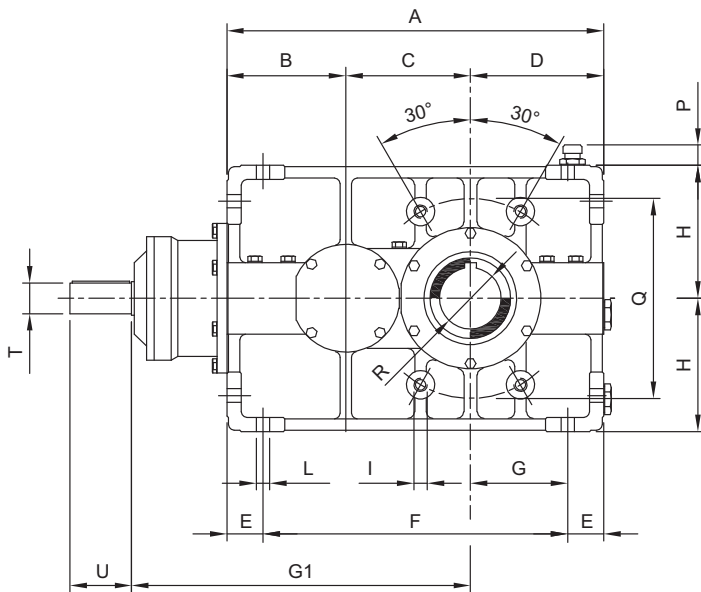
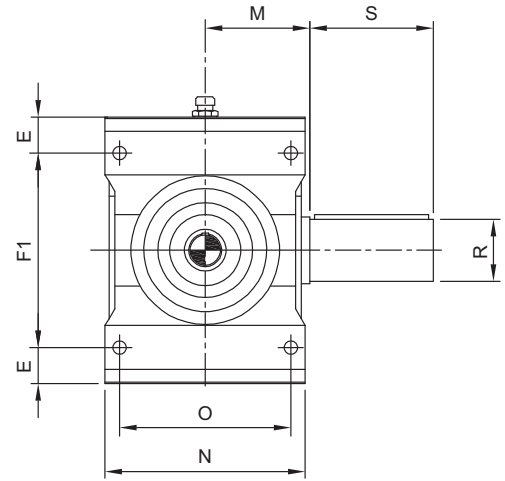
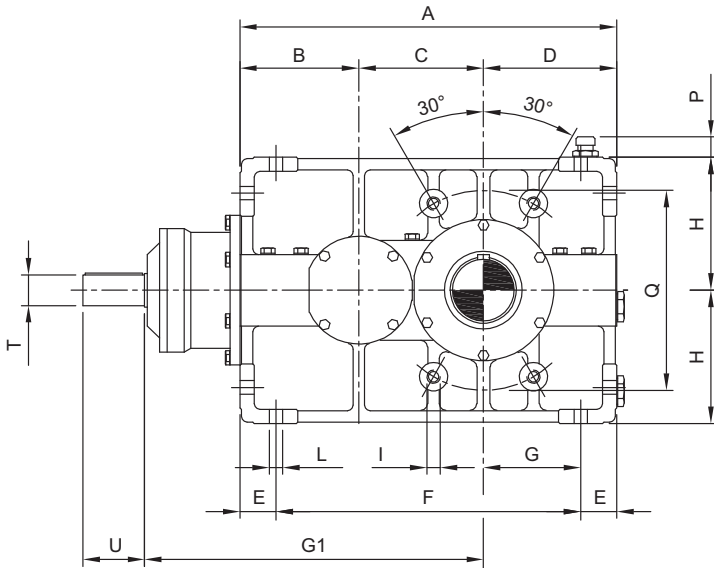

																			$i_N \leq 11.2$		$i_N \geq 12.5$		
	A	B	C	D	E	F	F1	G	G1	H	I	L	M	N	O	P	Q	R	S	T	U	T	U
10	396	125	131	140	38	320	204	102	356	140	M16	14	115	210	180	20	210	65	110	35	70	32	65
20	450	140	150	160	42	366	236	118	400	160	M18	16	135	235	200	22	240	80	140	40	80	35	70
30	510	160	170	180	46	418	268	134	450	180	M20	18	145	260	220	22	270	90	160	45	90	40	80
40	570	180	190	200	52	466	296	148	505	200	M22	20	160	295	250	22	300	100	180	50	100	45	90
50	641	200	216	225	57	527	336	168	571	225	M24	22	170	325	275	22	340	110	200	55	110	50	100
60	715	225	240	250	62	591	376	188	640	250	M27	25	190	360	300	22	380	120	210	60	120	55	110
70	792	250	262	280	72	648	416	208	712	280	M30	27	225	415	350	25	430	140	250	70	140	60	120
80	895	280	300	315	80	735	470	235	800	315	M33	30	250	455	385	25	490	160	280	80	160	70	140
90	1010	315	340	355	87	836	536	268	900	355	M36	33	280	535	460	25	560	170	300	90	180	80	160
100	1135	355	380	400	93	949	614	307	1010	400	M39	36	310	600	520	25	640	200	350	100	200	90	180
110	1282	400	432	450	100	1082	700	350	1142	450	M42	39	375	710	620	25	730	220	390	110	220	100	200



DIMENSIONI

Riduttori ad assi ortogonali
RVB due stadi

DIMENSIONAL DATA

RVB bevel-helical units - double stage

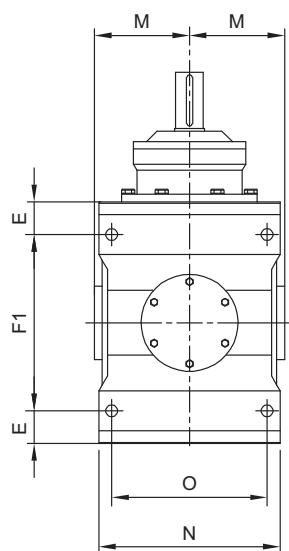
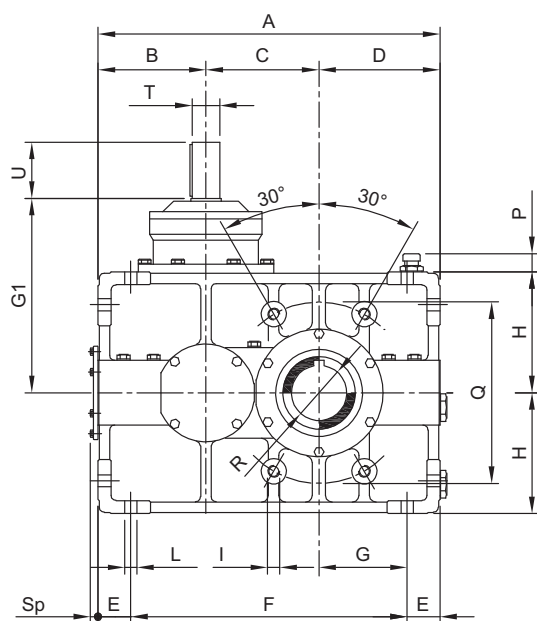
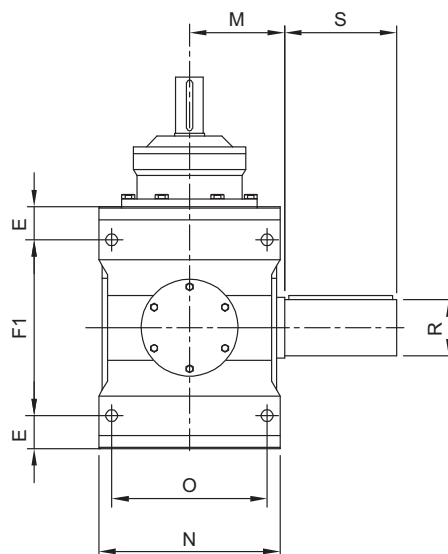
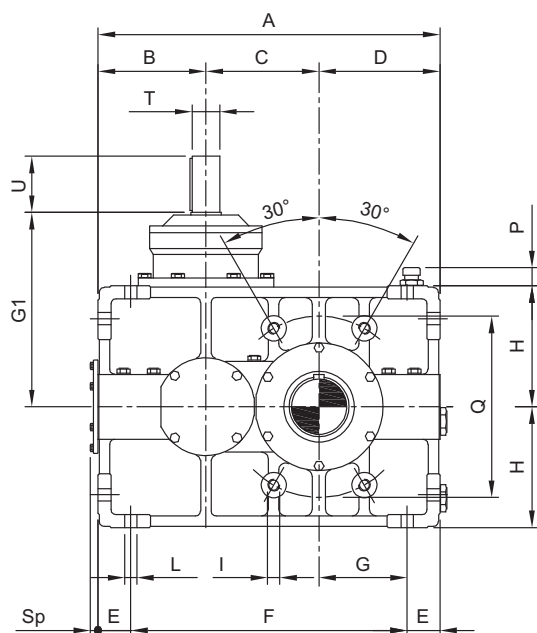

																				$i_N \leq 11.2$		$i_N \geq 12.5$		Sp
	A	B	C	D	E	F	F1	G	G1	H	I	L	M	N	O	P	Q	R	S	T	U	T	U	
10	396	125	131	140	38	320	204	102	225	140	M16	14	115	210	180	20	210	65	110	35	70	32	65	13
20	450	140	150	160	42	366	236	118	250	160	M18	16	135	235	200	22	240	80	140	40	80	35	70	16
30	510	160	170	180	46	418	268	134	280	180	M20	18	145	260	220	22	270	90	160	45	90	40	80	17
40	570	180	190	200	52	466	296	148	315	200	M22	20	160	295	250	22	300	100	180	50	100	45	90	18
50	641	200	216	225	57	527	336	168	355	225	M24	22	170	325	275	22	340	110	200	55	110	50	100	22
60	715	225	240	250	62	591	376	188	400	250	M27	25	190	360	300	22	380	120	210	60	120	55	110	23
70	792	250	262	280	72	648	416	208	450	280	M30	27	225	415	350	25	430	140	250	70	140	60	120	25
80	895	280	300	315	80	735	470	235	500	315	M33	30	250	455	385	25	490	160	280	80	160	70	140	26
90	1010	315	340	355	87	836	536	268	560	355	M36	33	280	535	460	25	560	170	300	90	180	80	160	29
100	1135	355	380	400	93	949	614	307	630	400	M39	36	310	600	520	25	640	200	350	100	200	90	180	30
110	1282	400	432	450	100	1082	700	350	710	450	M42	39	375	710	620	25	730	220	390	110	220	100	200	32



DIMENSIONI

Riduttori ad assi ortogonali
RHC tre stadi

DIMENSIONAL DATA

RHC bevel-helical units - triple stage

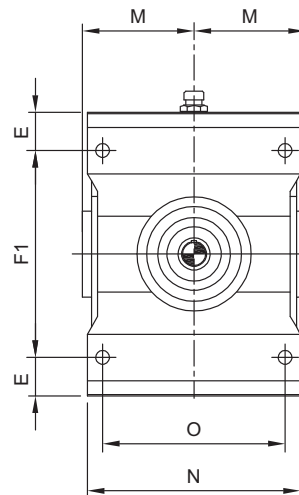
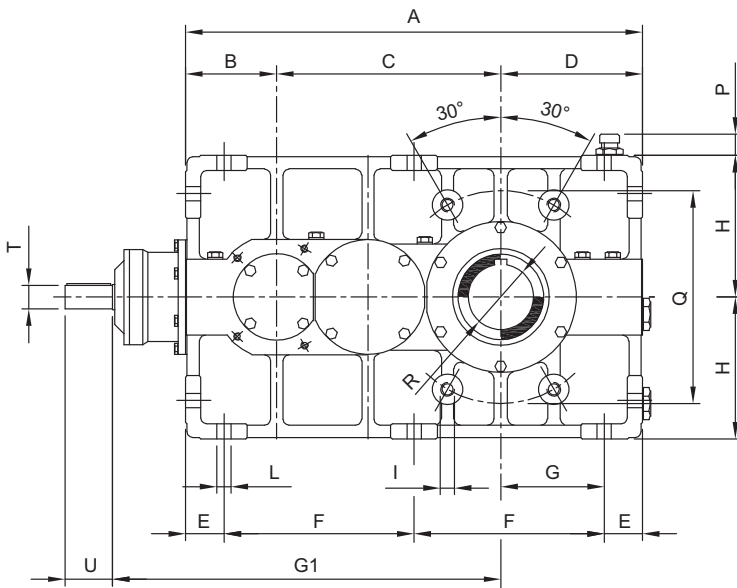
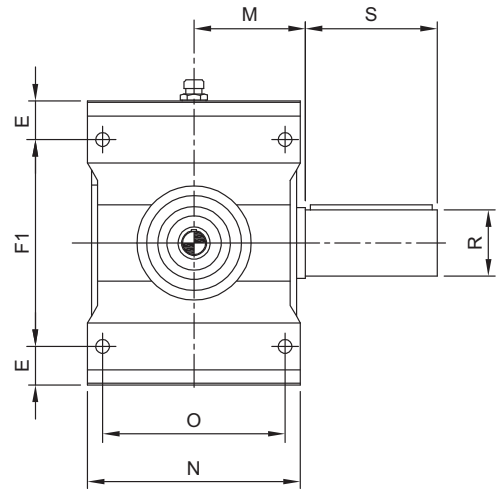
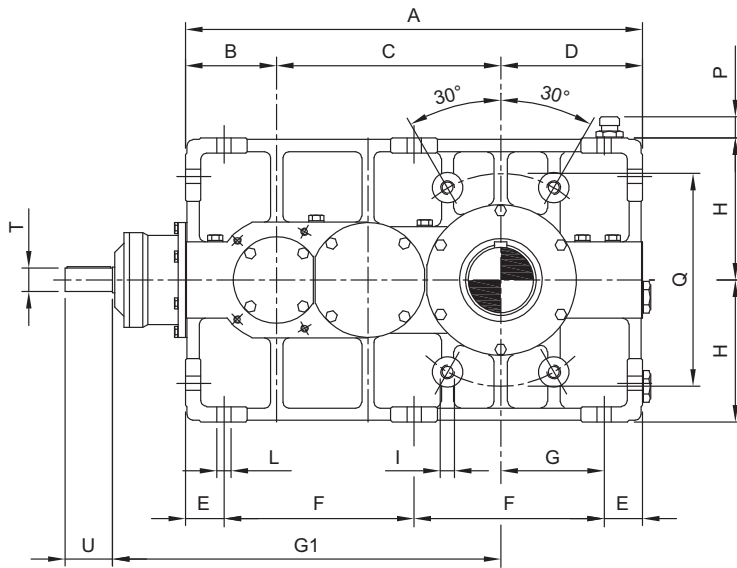

																				$i_N \leq 45$		$i_N \geq 50$	
	A	B	C	D	E	F	F1	G	G1	H	I	L	M	N	O	P	Q	R	S	T	U	T	U
10	451	90	221	140	38	187.5	204	102	381	140	M16	14	115	210	180	20	210	65	110	24	50	22	45
20	510	100	250	160	42	213	236	118	430	160	M18	16	135	235	200	22	240	80	140	28	55	24	50
30	574	112	282	180	46	241	268	134	482	180	M20	18	145	260	220	22	270	90	160	32	65	28	55
40	640	125	315	200	52	268	296	148	540	200	M22	20	160	295	250	22	300	100	180	35	70	32	65
50	721	140	356	225	57	303.5	336	168	606	225	M24	22	170	325	275	22	340	110	200	40	80	35	70
60	810	160	400	250	62	343	376	188	680	250	M27	25	190	360	300	22	380	120	210	45	90	40	80
70	902	180	442	280	72	379	416	208	757	280	M30	27	225	415	350	25	430	140	250	50	100	45	90
80	1015	200	500	315	80	427.5	470	235	855	315	M33	30	250	455	385	25	490	160	280	55	110	50	100
90	1145	225	565	355	87	485.5	536	268	965	355	M36	33	280	535	460	25	560	170	300	60	120	55	110
100	1280	250	630	400	93	547	614	307	1080	400	M39	36	310	600	520	25	640	200	350	70	140	60	120
110	1442	280	712	450	100	621	700	350	1212	450	M42	39	375	710	620	25	730	220	390	80	160	70	140



DIMENSIONI

Riduttori ad assi ortogonali
RVC tre stadi

DIMENSIONAL DATA

RVC bevel-helical units - triple stage

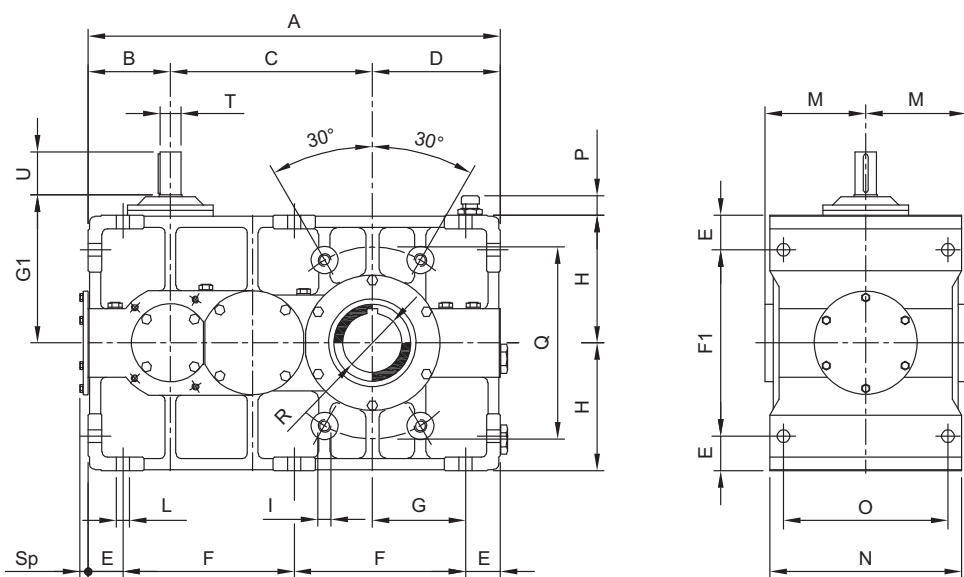
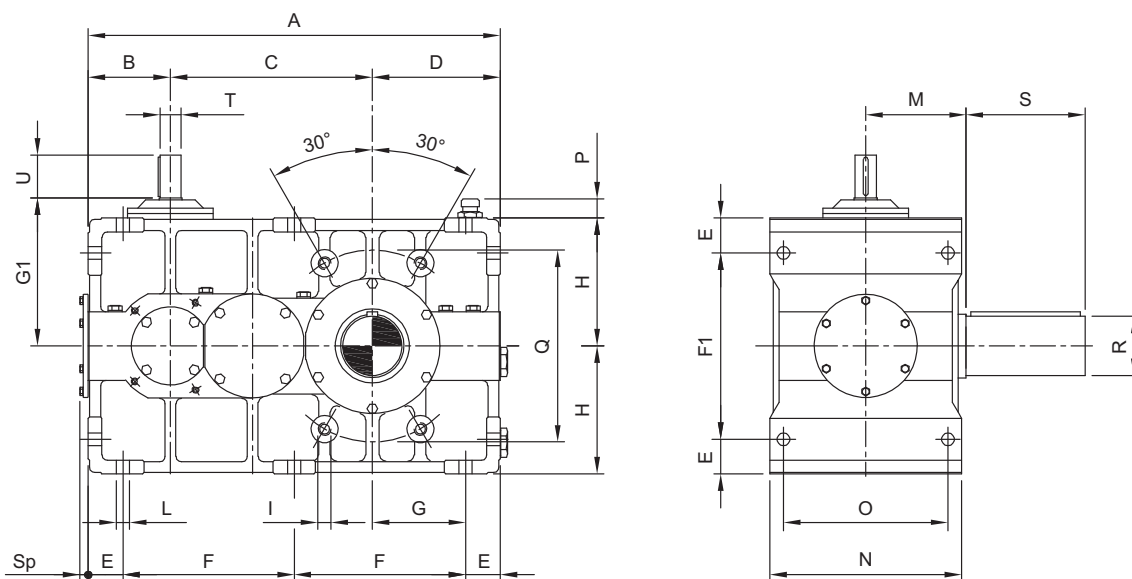

																				$i_N \leq 45$		$i_N \geq 50$		Sp
	A	B	C	D	E	F	F1	G	G1	H	I	L	M	N	O	P	Q	R	S	T	U	T	U	
10	451	90	221	140	38	187.5	204	102	160	140	M16	14	115	210	180	20	210	65	110	24	50	22	45	11
20	510	100	250	160	42	213	236	118	180	160	M18	16	135	235	200	22	240	80	140	28	55	24	50	11
30	574	112	282	180	46	241	268	134	200	180	M20	18	145	260	220	22	270	90	160	32	65	28	55	12
40	640	125	315	200	52	268	296	148	225	200	M22	20	160	295	250	22	300	100	180	35	70	32	65	13
50	721	140	356	225	57	303.5	336	168	250	225	M24	22	170	325	275	22	340	110	200	40	80	35	70	16
60	810	160	400	250	62	343	376	188	280	250	M27	25	190	360	300	22	380	120	210	45	90	40	80	17
70	902	180	442	280	72	379	416	208	315	280	M30	27	225	415	350	25	430	140	250	50	100	45	90	18
80	1015	200	500	315	80	427.5	470	235	355	315	M33	30	250	455	385	25	490	160	280	55	110	50	100	22
90	1145	225	565	355	87	485.5	536	268	400	355	M36	33	280	535	460	25	560	170	300	60	120	55	110	23
100	1280	250	630	400	93	547	614	307	450	400	M39	36	310	600	520	25	640	200	350	70	140	60	120	25
110	1442	280	712	450	100	621	700	350	500	450	M42	39	375	710	620	25	730	220	390	80	160	70	140	26



DIMENSIONI

Riduttori ad assi ortogonali
RHD quattro stadi

DIMENSIONAL DATA

RHD bevel-helical units - quadruple stage

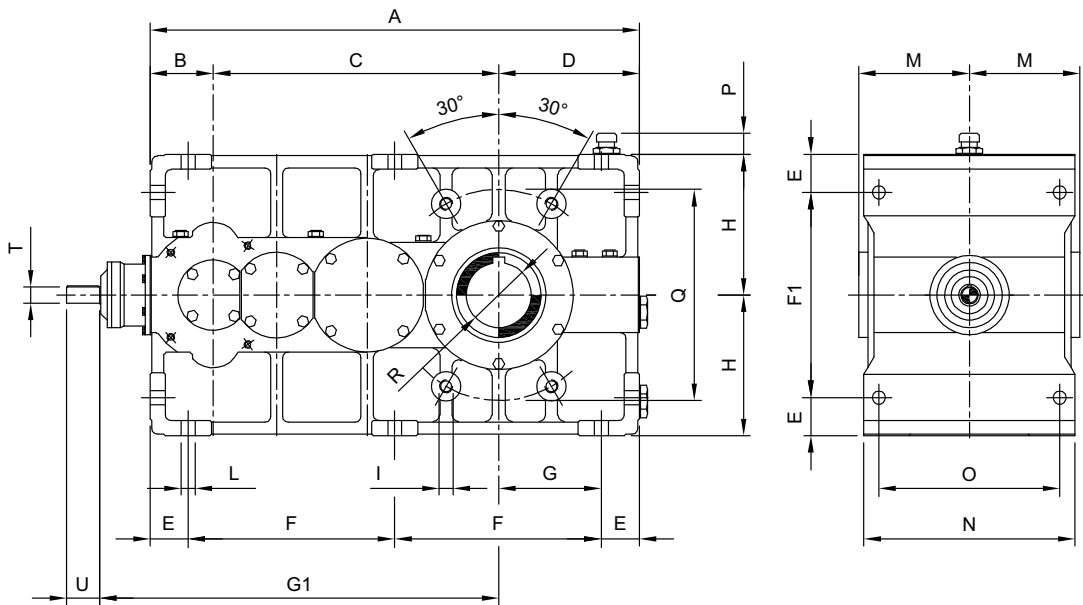
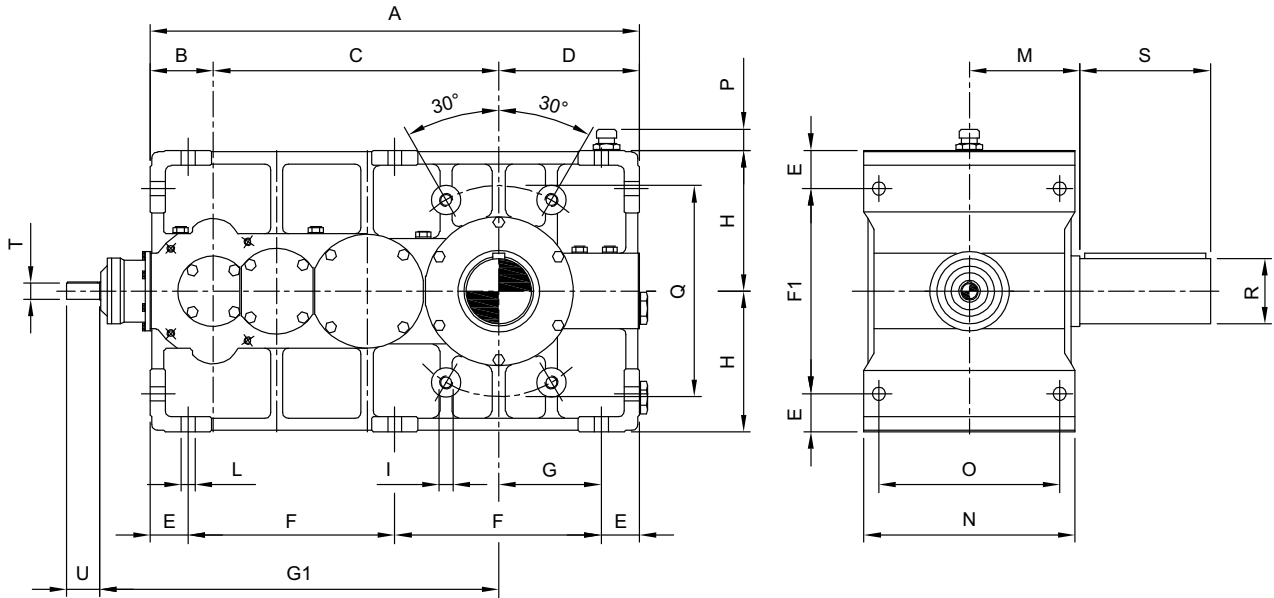

																				$i_N \leq 200$		$i_N \geq 225$	
	A	B	C	D	E	F	F1	G	G1	H	I	L	M	N	O	P	Q	R	S	T	U	T	U
10	487	63	284	140	38	205.5	204	102	396	140	M16	14	115	210	180	20	210	65	110	20	40	20	40
20	550	70	320	160	42	233	236	118	445	160	M18	16	135	235	200	22	240	80	140	20	40	20	40
30	622	80	362	180	46	265	268	134	502	180	M20	18	145	260	220	22	270	90	160	22	45	20	40
40	695	90	405	200	52	295.5	296	148	565	200	M22	20	160	295	250	22	300	100	180	24	50	22	45
50	781	100	456	225	57	333.5	336	168	636	225	M24	22	170	325	275	22	340	110	200	28	55	24	50
60	874	112	512	250	62	375	376	188	712	250	M27	25	190	360	300	22	380	120	210	32	65	28	55
70	972	125	567	280	72	414	416	208	792	280	M30	27	225	415	350	25	430	140	250	35	70	32	65
80	1095	140	640	315	80	467.5	470	235	890	315	M33	30	250	455	385	25	490	160	280	40*	80*	35**	70**
90	1240	160	725	355	87	533	536	268	1005	355	M36	33	280	535	460	25	560	170	300	45	90	40	80
100	1390	180	810	400	93	602	614	307	1125	400	M39	36	310	600	520	25	640	200	350	50	100	45	90
110	1562	200	912	450	100	681	700	350	1267	450	M42	39	375	710	620	25	730	220	390	55	110	50	100

* $i_N \leq 225$

** $i_N \geq 250$



DIMENSIONI

Riduttori ad assi ortogonali
RVD quattro stadi

DIMENSIONAL DATA

RVD bevel-helical units - quadruple stage

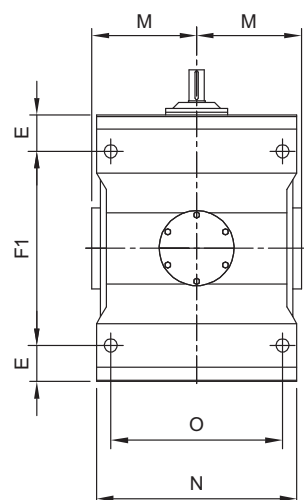
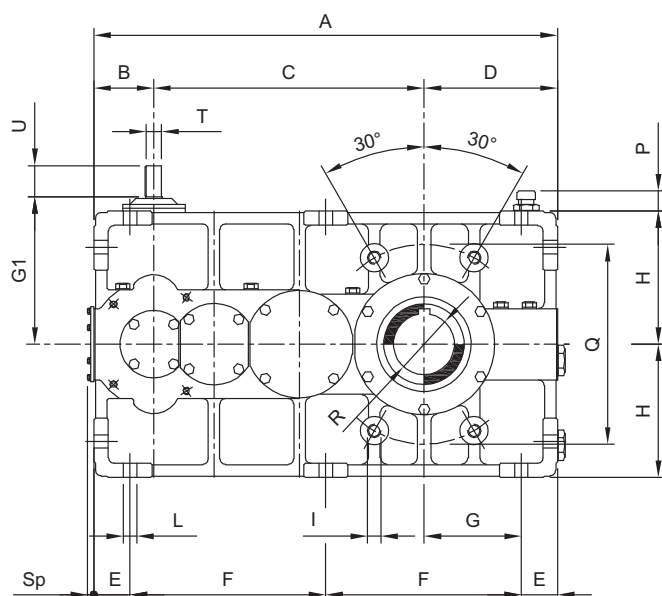
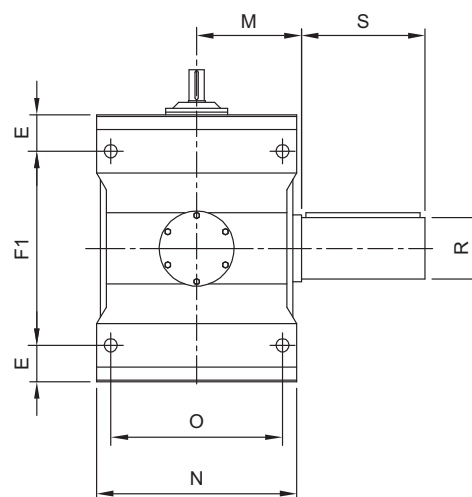
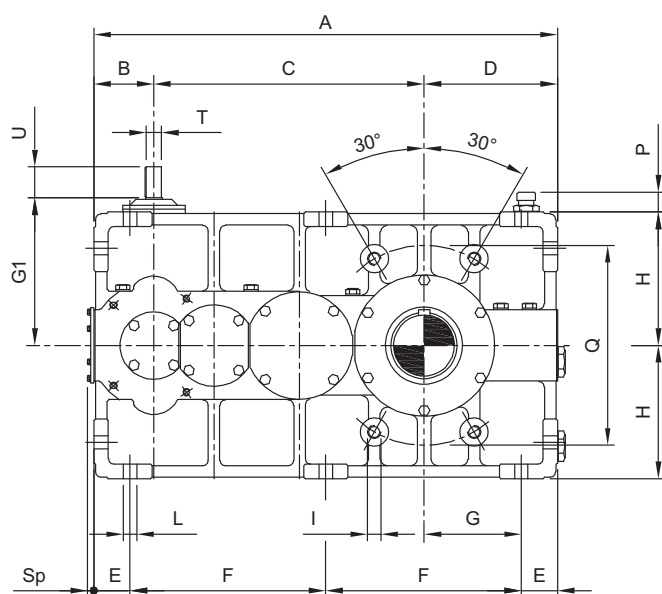

																					$i_N \leq 200$		$i_N \geq 225$		Sp
	A	B	C	D	E	F	F1	G	G1	H	I	L	M	N	O	P	Q	R	S	T	U	T	U		
10	487	63	284	140	38	205.5	204	102	160	140	M16	14	115	210	180	20	210	65	110	20	40	20	40	10	
20	550	70	320	160	42	233	236	118	180	160	M18	16	135	235	200	22	240	80	140	20	40	20	40	10	
30	622	80	362	180	46	265	268	134	200	180	M20	18	145	260	220	22	270	90	160	22	45	20	40	11	
40	695	90	405	200	52	295.5	296	148	225	200	M22	20	160	295	250	22	300	100	180	24	50	22	45	11	
50	781	100	456	225	57	333.5	336	168	250	225	M24	22	170	325	275	22	340	110	200	28	55	24	50	11	
60	874	112	512	250	62	375	376	188	280	250	M27	25	190	360	300	22	380	120	210	32	65	28	55	12	
70	972	125	567	280	72	414	416	208	315	280	M30	27	225	415	350	25	430	140	250	35	70	32	65	13	
80	1095	140	640	315	80	467.5	470	235	355	315	M33	30	250	455	385	25	490	160	280	40	80	35	70	16	
90	1240	160	725	355	87	533	536	268	400	355	M36	33	280	535	460	25	560	170	300	45	90	40	80	17	
100	1390	180	810	400	93	602	614	307	450	400	M39	36	310	600	520	25	640	200	350	50	100	45	90	18	
110	1562	200	912	450	100	681	700	350	500	450	M42	39	375	710	620	25	730	220	390	55	110	50	100	22	



ESECUZIONE GRAFICA

SHAFT ARRANGEMENTS

PA						
PB						
PC						
PD						



ESECUZIONE GRAFICA

SHAFT ARRANGEMENTS

RHB				
RVB				
RHC				
RVC				



ESECUZIONE GRAFICA

SHAFT ARRANGEMENTS

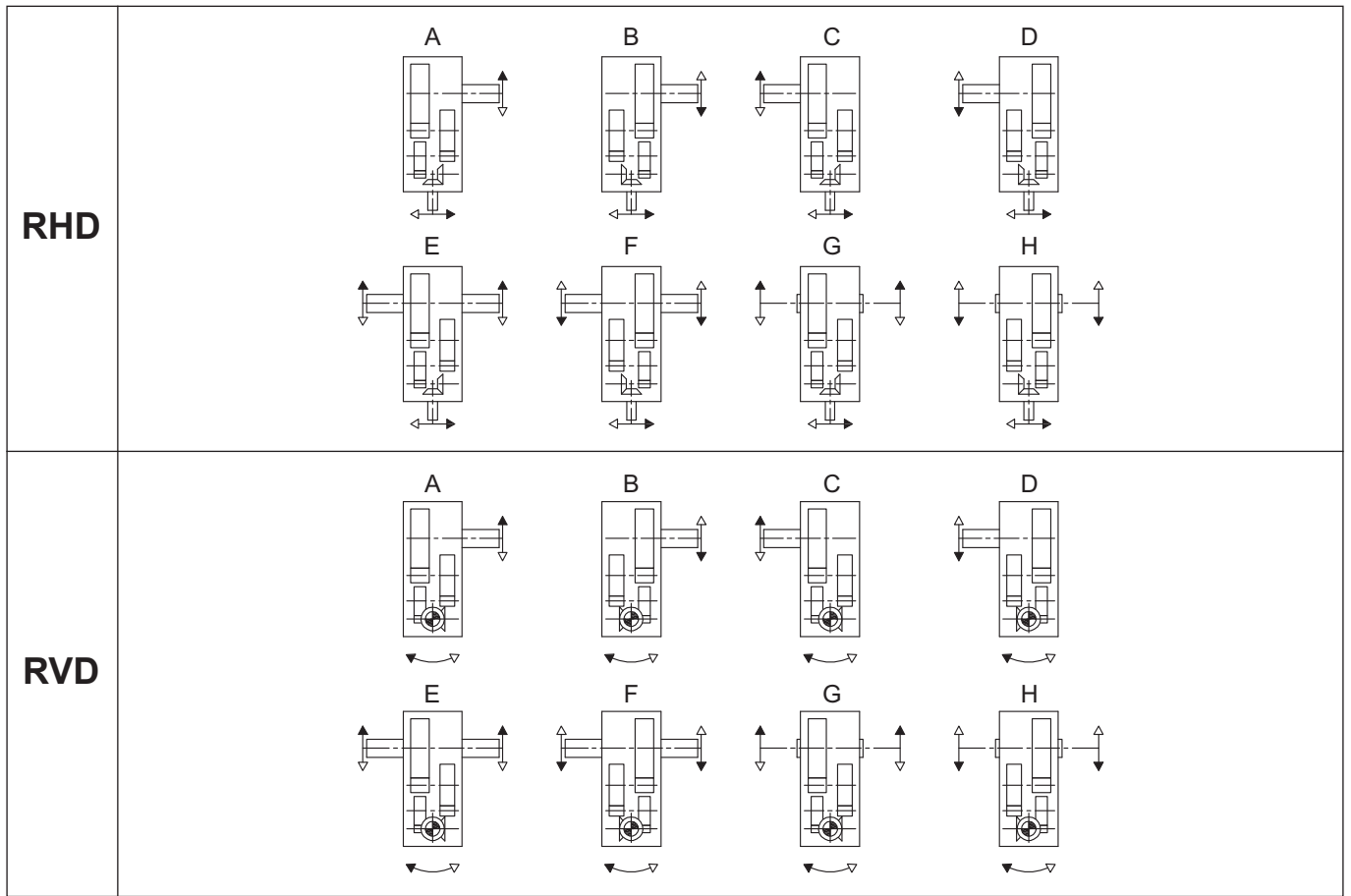

FORMA COSTRUTTIVA

MOUNTING POSITIONS

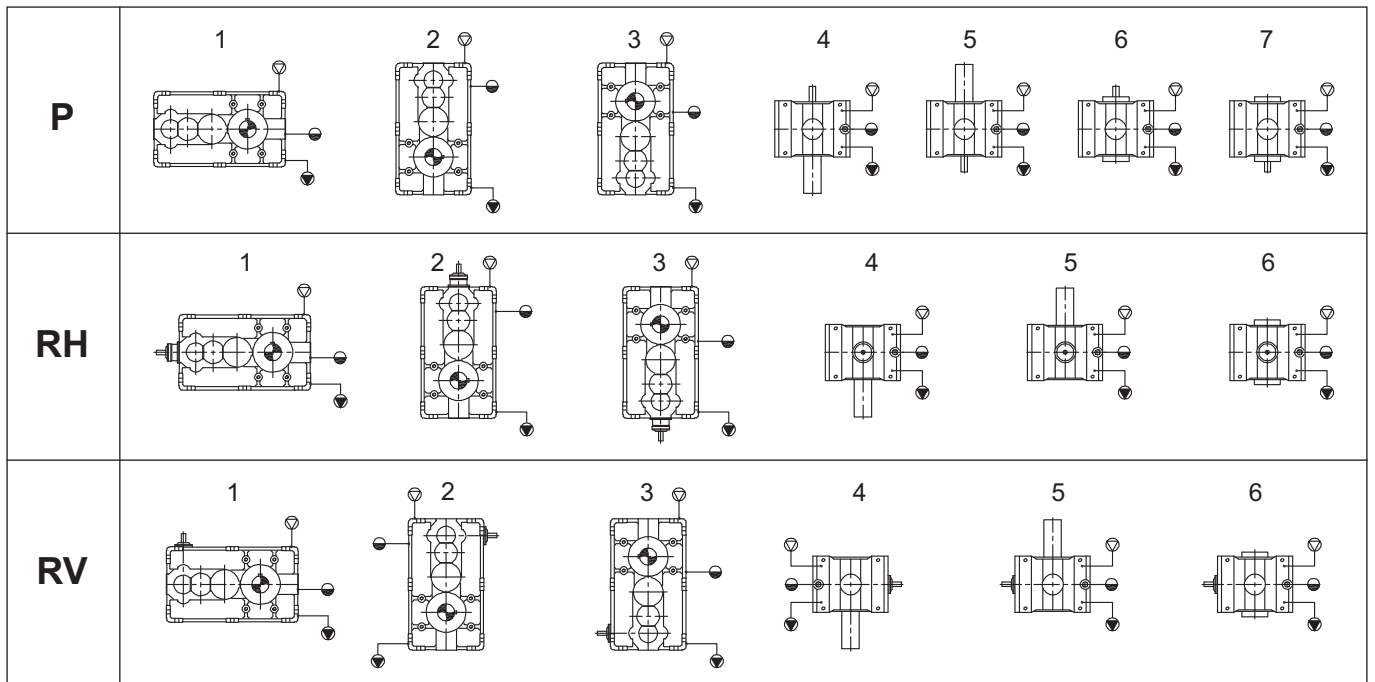

Tappo carico - *Breather plug*

Tappo livello - *Level plug*

Tappo scarico - *Drain plug*



ACCOPIAMENTI PER MOTORI ELETTRICI

Riduttori ad assi paralleli PB

ELECTRIC MOTORS COUPLINGS

PB helical units

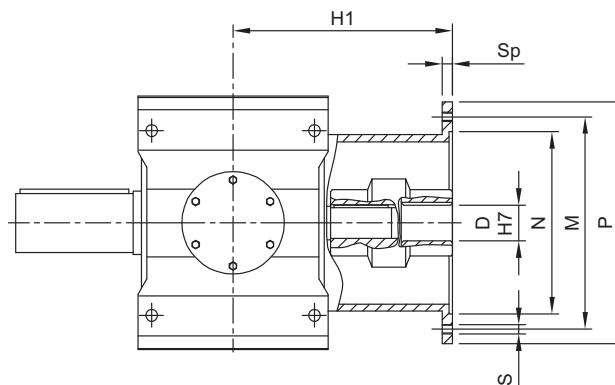
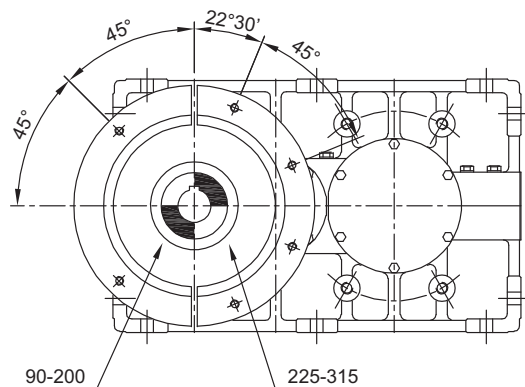

	Motore - Motor IEC	D	M	N	P	S	Sp	H1
10	90	24	165	130	200	M10	12	224
	100-112	28	215	180	250	M12	14	234
	132	38	265	230	300	M12	16	254
	160	42	300	250	350	M16	18	284
	180	48	300	250	350	M16	18	284
20	100-112	28	215	180	250	M12	14	264
	132	38	265	230	300	M12	16	284
	160	42	300	250	350	M16	18	314
	180	48	300	250	350	M16	18	314
	200	55	350	300	400	M16	20	314
30	100-112	28	215	180	250	M12	14	279
	132	38	265	230	300	M12	16	299
	160	42	300	250	350	M16	18	329
	180	48	300	250	350	M16	18	329
	200	55	350	300	400	M16	20	329
40	225	60	400	350	450	M16	20	359
	132	38	265	230	300	M12	16	334
	160	42	300	250	350	M16	18	364
	180	48	300	250	350	M16	18	364
	200	55	350	300	400	M16	20	364
50	225	60	400	350	450	M16	20	394
	250	65	500	450	550	M16	20	394
	132	38	265	230	300	M12	16	354
	160	42	300	250	350	M16	18	384
	180	48	300	250	350	M16	18	384
60	200	55	350	300	400	M16	20	384
	225	60	400	350	450	M16	20	414
	250	65	500	450	550	M16	20	414
	280	75	500	450	550	M16	20	414
	160	42	300	250	350	M16	18	414
70	180	48	300	250	350	M16	18	414
	200	55	350	300	400	M16	20	444
	225	60	400	350	450	M16	20	444
	250	65	500	450	550	M16	20	444
	280	75	500	450	550	M16	20	479
80	160	42	300	250	350	M16	18	479
	180	48	300	250	350	M16	18	479
	200	55	350	300	400	M16	20	509
	225	60	400	350	450	M16	20	509
	250	65	500	450	550	M16	20	509
90	280	75	500	450	550	M16	20	509
	200	55	350	300	400	M16	20	514
	225	60	400	350	450	M16	20	544
	250	65	500	450	550	M16	20	544
	280	75	500	450	550	M16	20	544
90	315	80	600	550	660	M20	24	574
	200	55	350	300	400	M16	20	564
	225	60	400	350	450	M16	20	594
	250	65	500	450	550	M16	20	594
	280	75	500	450	550	M16	20	594
	315	80	600	550	660	M20	24	624



ACCOPIAMENTI PER MOTORI ELETTRICI

Riduttori ad assi paralleli PC

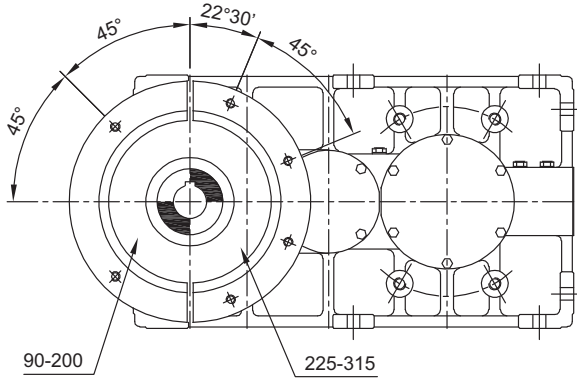

ELECTRIC MOTORS COUPLINGS

PC helical units

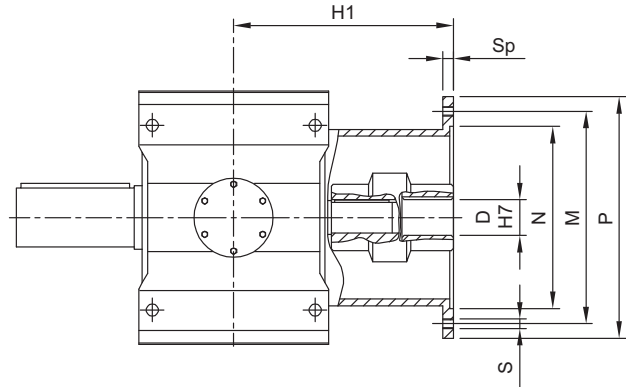

	Motore - Motor IEC	D	M	N	P	S	Sp	H1
10	90	24	165	130	200	M10	12	219
	100-112	28	215	180	250	M12	14	229
	132	38	265	230	300	M12	16	249
	160	42	300	250	350	M16	18	279
	180	48	300	250	350	M16	18	279
20	100-112	28	215	180	250	M12	14	249
	132	38	265	230	300	M12	16	269
	160	42	300	250	350	M16	18	299
	180	48	300	250	350	M16	18	299
	200	55	350	300	400	M16	20	299
30	100-112	28	215	180	250	M12	14	264
	132	38	265	230	300	M12	16	284
	160	42	300	250	350	M16	18	314
	180	48	300	250	350	M16	18	314
	200	55	350	300	400	M16	20	314
40	225	60	400	350	450	M16	20	344
	132	38	265	230	300	M12	16	234
	160	42	300	250	350	M16	18	334
	180	48	300	250	350	M16	18	334
	200	55	350	300	400	M16	20	334
50	225	60	400	350	450	M16	20	364
	132	38	265	230	300	M12	16	319
	160	42	300	250	350	M16	18	349
	180	48	300	250	350	M16	18	349
	200	55	350	300	400	M16	20	349
60	225	60	400	350	450	M16	20	379
	250	65	500	450	550	M16	20	379
	132	38	265	230	300	M12	16	349
	160	42	300	250	350	M16	18	379
	180	48	300	250	350	M16	18	379
70	200	55	350	300	400	M16	20	379
	225	60	400	350	450	M16	20	409
	250	65	500	450	550	M16	20	409
	280	75	500	450	550	M16	20	409
	160	42	300	250	350	M16	18	429
80	180	48	300	250	350	M16	18	429
	200	55	350	300	400	M16	20	429
	225	60	400	350	450	M16	20	459
	250	65	500	450	550	M16	20	459
	280	75	500	450	550	M16	20	459
90	180	48	300	250	350	M16	18	464
	200	55	350	300	400	M16	20	464
	225	60	400	350	450	M16	20	494
	250	65	500	450	550	M16	20	494
	280	75	500	450	550	M16	20	494
90	200	55	350	300	400	M16	20	504
	225	60	400	350	450	M16	20	534
	250	65	500	450	550	M16	20	534
	280	75	500	450	550	M16	20	534
	315	80	600	550	660	M20	24	564



ACCOPIAMENTI PER MOTORI ELETTRICI

ELECTRIC MOTORS COUPLINGS

Riduttori ad assi paralleli PD

PD helical units

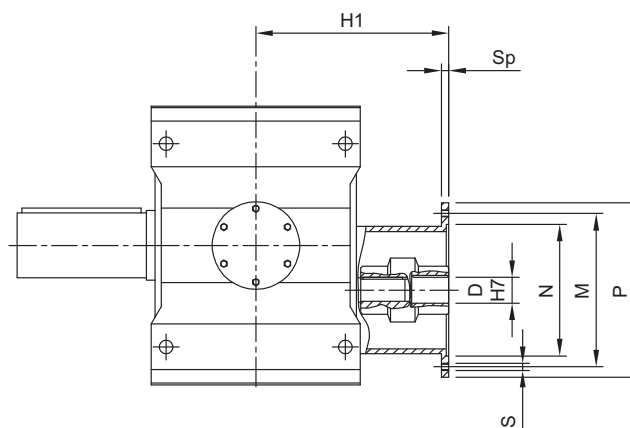
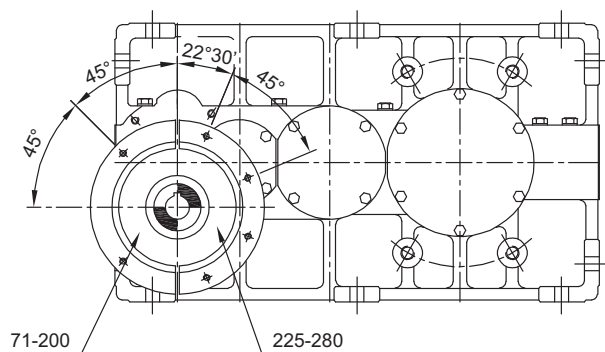

	Motore - Motor IEC	D	M	N	P	S	Sp	H1
10	71	14	130	110	160	M8	12	184
	80	19	165	130	200	M10	12	194
	90	24	165	130	200	M10	12	204
	100-112	28	215	180	250	M12	14	214
20	132	38	265	230	300	M12	16	234
	80	19	165	130	200	M10	12	214
	90	24	165	130	200	M10	12	224
	100-112	28	215	180	250	M12	14	234
30	132	38	265	230	300	M12	16	254
	80	19	165	130	200	M10	12	239
	90	24	165	130	200	M10	12	249
	100-112	28	215	180	250	M12	14	259
40	132	38	265	230	300	M12	16	279
	160	42	300	250	350	M16	18	309
	90	24	165	130	200	M10	12	264
	100-112	28	215	180	250	M12	14	274
50	132	38	265	230	300	M12	16	294
	160	42	300	250	350	M16	18	324
	100-112	28	215	180	250	M12	14	284
	132	38	265	230	300	M12	16	304
60	160	42	300	250	350	M16	18	334
	180	48	300	250	350	M16	18	359
	100-112	28	215	180	250	M12	14	309
	132	38	265	230	300	M12	16	329
70	160	42	300	250	350	M16	18	359
	180	48	300	250	350	M16	18	359
	200	55	350	300	400	M16	20	359
	100-112	28	215	180	250	M12	14	344
80	132	38	265	230	300	M12	16	364
	160	42	300	250	350	M16	18	394
	180	48	300	250	350	M16	18	394
	200	55	350	300	400	M16	20	394
90	225	60	400	350	450	M16	20	424
	132	38	265	230	300	M12	16	399
	160	42	300	250	350	M16	18	429
	180	48	300	250	350	M16	18	429
90	200	55	350	300	400	M16	20	429
	225	60	400	350	450	M16	20	459
	250	65	500	450	550	M16	20	459
	132	38	265	230	300	M12	16	434
	160	42	300	250	350	M16	18	464
	180	48	300	250	350	M16	18	464
90	200	55	350	300	400	M16	20	464
	225	60	400	350	450	M16	20	494
	250	65	500	450	550	M16	20	494
	280	75	500	450	550	M16	20	494



ACCOPIAMENTI PER MOTORI ELETTRICI

ELECTRIC MOTORS COUPLINGS

Riduttori ad assi ortogonali RHB/RVB

RHB/RVB bevel-helical units

RHB

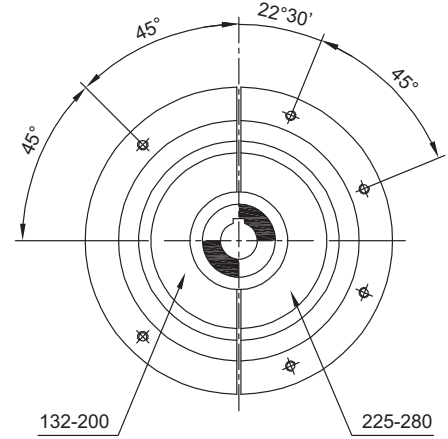
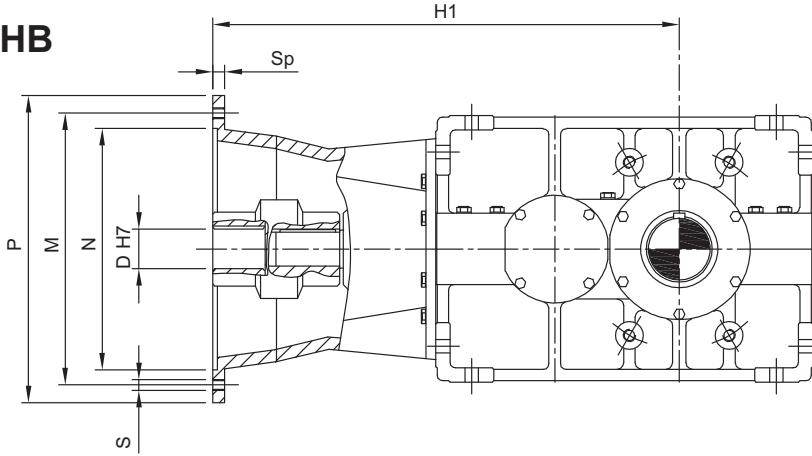

RVB

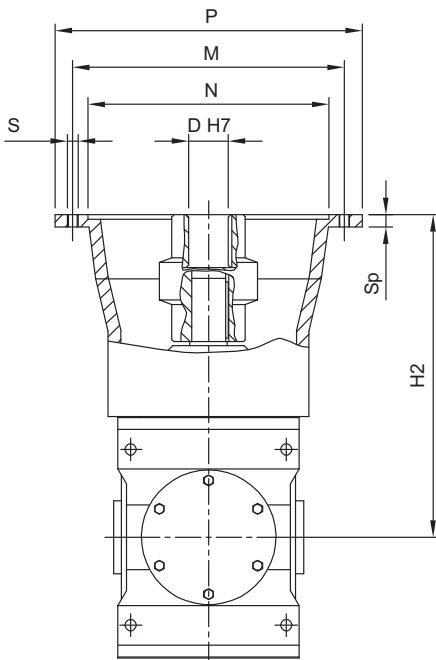

	Motore - Motor IEC	D	M	N	P	S	Sp	H1	H2
10	132	38	265	230	300	M12	16	510	379
	160	42	300	250	350	M16	18	540	409
	180	48	300	250	350	M16	18	540	409
	200	55	350	300	400	M16	20	540	409
20	132	38	265	230	300	M12	16	564	414
	160	42	300	250	350	M16	18	594	444
	180	48	300	250	350	M16	18	594	444
	200	55	350	300	400	M16	20	594	444
30	225	60	400	350	450	M16	20	624	474
	160	42	300	250	350	M16	18	654	484
	180	48	300	250	350	M16	18	654	484
	200	55	350	300	400	M16	20	654	484
40	225	60	400	350	450	M16	20	684	514
	250	65	500	450	550	M16	20	684	514
	160	42	300	250	350	M16	18	719	529
	180	48	300	250	350	M16	18	719	529
50	200	55	350	300	400	M16	20	749	559
	225	60	400	350	450	M16	20	749	559
	250	65	500	450	550	M16	20	749	559
	160	42	300	250	350	M16	18	795	579
60	180	48	300	250	350	M16	18	795	579
	200	55	350	300	400	M16	20	795	579
	225	60	400	350	450	M16	20	825	609
	250	65	500	450	550	M16	20	825	609
70	280	75	500	450	550	M16	20	825	609
	200	55	350	300	400	M16	20	874	634
	225	60	400	350	450	M16	20	904	664
	250	65	500	450	550	M16	20	904	664
80	280	75	500	450	550	M16	20	904	664
	200	55	350	300	400	M16	20	966	704
	225	60	400	350	450	M16	20	996	734
	250	65	500	450	550	M16	20	996	734
90	280	75	500	450	550	M16	20	996	734
	200	55	350	300	400	M16	20	1074	774
	225	60	400	350	450	M16	20	1104	804
	250	65	500	450	550	M16	20	1104	804
90	280	75	500	450	550	M16	20	1104	804
	200	55	350	300	400	M16	20	1194	854
	225	60	400	350	450	M16	20	1224	884
	250	65	500	450	550	M16	20	1224	884
90	280	75	500	450	550	M16	20	1224	884



ACCOPIAMENTI PER MOTORI ELETTRICI

ELECTRIC MOTORS COUPLINGS

Riduttori ad assi ortogonali RHC/RVC

RHC/RVC bevel-helical units

RHC

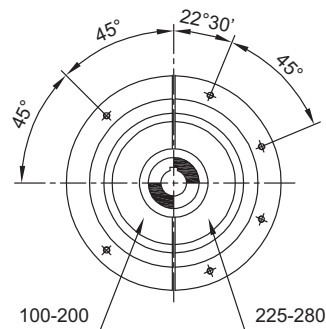
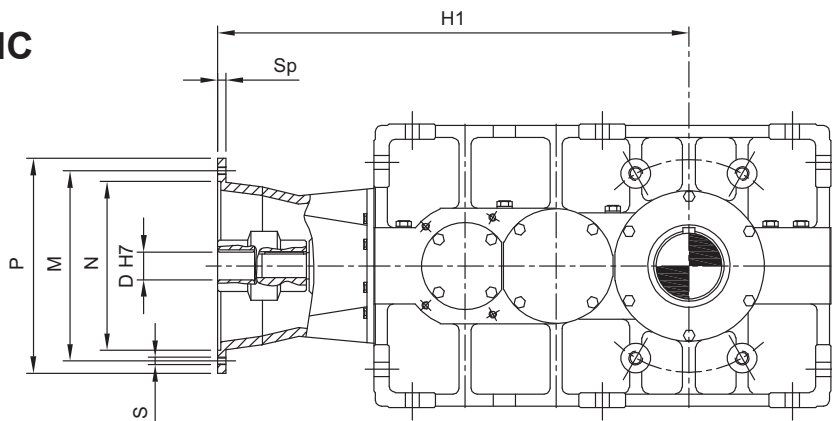

RVC

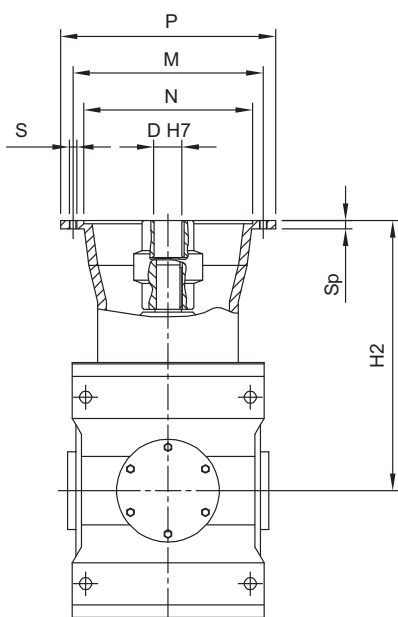

	Motore - Motor IEC	D	M	N	P	S	Sp	H1	H2
10	100-112	28	215	180	250	M12	14	495	274
	132	38	265	230	300	M12	16	515	294
	160	42	300	250	350	M16	18	545	324
	180	48	300	250	350	M16	18	545	324
20	100-112	28	215	180	250	M12	14	549	299
	132	38	265	230	300	M12	16	569	319
	160	42	300	250	350	M16	18	599	349
	180	48	300	250	350	M16	18	599	349
	200	55	350	300	400	M16	20	599	349
30	132	38	265	230	300	M12	16	631	349
	160	42	300	250	350	M16	18	661	379
	180	48	300	250	350	M16	18	661	379
	200	55	350	300	400	M16	20	661	379
	225	60	400	350	450	M16	20	691	409
40	132	38	265	230	300	M12	16	694	379
	160	42	300	250	350	M16	18	724	409
	180	48	300	250	350	M16	18	724	409
	200	55	350	300	400	M16	20	724	409
	225	60	400	350	450	M16	20	754	439
50	250	65	500	450	550	M16	20	754	439
	160	42	300	250	350	M16	18	800	444
	180	48	300	250	350	M16	18	800	444
	200	55	350	300	400	M16	20	800	444
	225	60	400	350	450	M16	20	830	474
	250	65	500	450	550	M16	20	830	474
60	280	75	500	450	550	M16	20	830	474
	180	48	300	250	350	M16	18	884	484
	200	55	350	300	400	M16	20	884	484
	225	60	400	350	450	M16	20	914	514
	250	65	500	450	550	M16	20	914	514
70	280	75	500	450	550	M16	20	914	514
	200	55	350	300	400	M16	20	971	529
	225	60	400	350	450	M16	20	1001	559
	250	65	500	450	550	M16	20	1001	559
80	280	75	500	450	550	M16	20	1001	559
	225	60	400	350	450	M16	20	1109	609
	250	65	500	450	550	M16	20	1109	609
90	280	75	500	450	550	M16	20	1109	609
	250	65	500	450	550	M16	20	1229	664
	280	75	500	450	550	M16	20	1229	664



ACCOPIAMENTI PER MOTORI ELETTRICI

ELECTRIC MOTORS COUPLINGS

Riduttori ad assi ortogonali RHD/RVD

RHD/RVD bevel-helical units

RHD

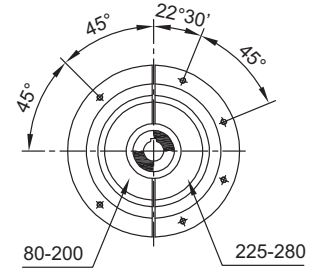
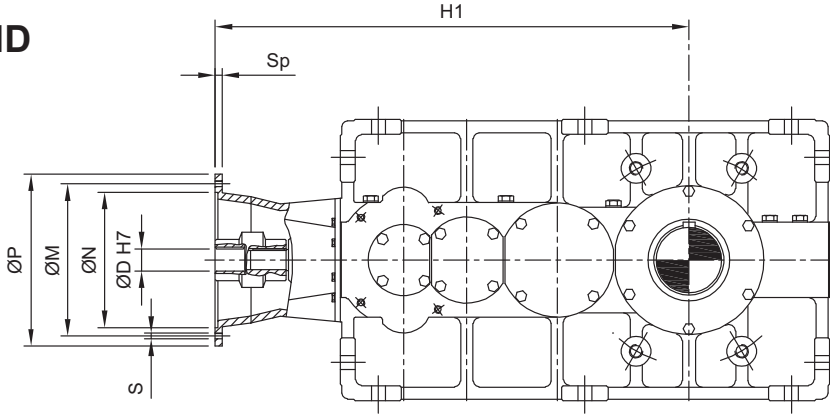

RVD

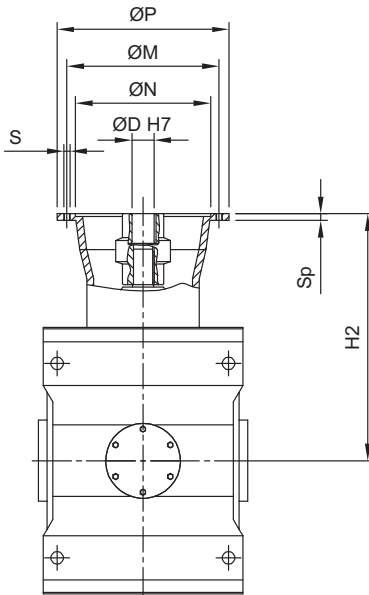

	Motore - Motor IEC	D	M	N	P	S	Sp	H1	H2
10	80	19	165	130	200	M10	12	480	244
	90	24	165	130	200	M10	12	490	254
	100-112	28	215	180	250	M12	14	500	264
20	90	24	165	130	200	M10	12	539	274
	100-112	28	215	180	250	M12	14	549	284
	132	38	265	230	300	M12	16	569	304
30	90	24	165	130	200	M10	12	601	299
	100-112	28	215	180	250	M12	14	611	309
	132	38	265	230	300	M12	16	631	329
40	160	42	300	250	350	M16	18	661	359
	100-112	28	215	180	250	M12	14	679	339
	132	38	265	230	300	M12	16	699	359
50	160	42	300	250	350	M16	18	729	389
	100-112	28	215	180	250	M12	14	755	369
	132	38	265	230	300	M12	16	775	389
60	160	42	300	250	350	M16	18	805	419
	180	48	300	250	350	M16	18	805	419
	100-112	28	215	180	250	M12	14	841	409
70	132	38	265	230	300	M12	16	861	429
	160	42	300	250	350	M16	18	891	459
	180	48	300	250	350	M16	18	891	459
80	200	55	350	300	400	M16	20	891	459
	132	38	265	230	300	M12	16	946	469
	160	42	300	250	350	M16	18	976	499
90	180	48	300	250	350	M16	18	976	499
	200	55	350	300	400	M16	20	976	499
	225	60	400	350	450	M16	20	1006	529
80	132	38	265	230	300	M12	16	1054	519
	160	42	300	250	350	M16	18	1084	549
	180	48	300	250	350	M16	18	1084	549
	200	55	350	300	400	M16	20	1084	549
	225	60	400	350	450	M16	20	1114	579
	250	65	500	450	550	M16	20	1114	579
90	160	42	300	250	350	M16	18	1209	604
	180	48	300	250	350	M16	18	1209	604
	200	55	350	300	400	M16	20	1209	604
	225	60	400	350	450	M16	20	1239	634
	250	65	500	450	550	M16	20	1239	634
	280	75	500	450	550	M16	20	1239	634



ESTREMITÀ D'ALBERO

Albero pieno con linguetta

SHAFT ENDING

Solid shaft with key

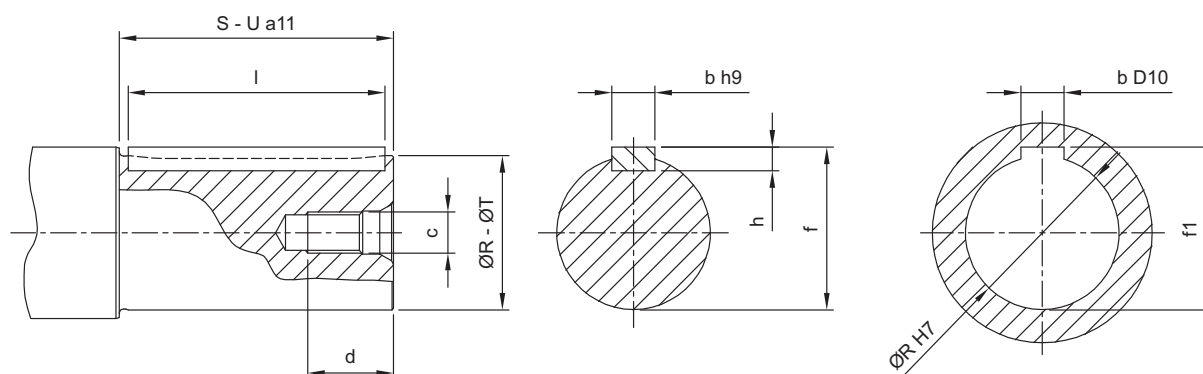

R-T	S-U	c	d	Linguetta - Key			f	f1
				b	h	l		
18 j6	35	M6	16	6	6	30	20.5	20.8
20 j6	40	M6	16	6	6	35	22.5	22.8
22 j6	45	M6	16	6	6	40	24.5	24.8
24 j6	50	M8	19	8	7	45	27	27.3
28 j6	55	M8	19	8	7	50	31	31.3
30 k6	60	M8	19	8	7	55	33	33.3
32 k6	65	M10	22	10	8	60	35	35.3
35 k6	70	M10	22	10	8	60	38	38.3
40 k6	80	M10	22	12	8	70	43	43.3
45 k6	90	M10	22	14	9	80	48.5	48.8
50 k6	100	M12	28	14	9	90	53.5	53.8
55 m6	110	M12	28	16	10	100	59	59.3
60 m6	120	M12	28	18	11	110	64	64.4
65 m6	110	M16	36	18	11	100	69	69.4
70 m6	140	M16	36	20	12	125	74.5	74.9
75 m6	150	M16	36	20	12	125	79.5	79.9
80 m6	140	M16	36	22	14	125	85	85.4
80 m6	160	M16	36	22	14	140	85	85.4
85 m6	170	M16	36	22	14	140	90	90.4
90 m6	160	M16	36	25	14	140	95	95.4
90 m6	180	M20	36	25	14	160	95	95.4
100 m6	180	M20	42	28	16	160	106	106.4
100 m6	200	M20	42	28	16	180	106	106.4
110 m6	200	M20	42	28	16	180	116	116.4
110 m6	220	M20	42	28	16	200	116	116.4
120 m6	210	M20	42	32	18	180	127	127.4
130 m6	260	M20	42	32	18	220	137	137.4
140 m6	250	M24	50	36	20	220	148	148.4
140 m6	280	M24	50	36	20	250	148	148.4
150 m6	300	M24	50	36	20	280	158	158.4
160 m6	280	M24	50	40	22	250	169	169.4
160 m6	320	M24	50	40	22	280	169	169.4
170 m6	300	M24	50	40	22	280	179	179.4
180 m6	360	M24	50	45	25	320	190	190.4
190 m6	380	M30	64	45	25	360	200	200.4
200 m6	350	M30	64	45	25	320	210	210.4
220 m6	390	M30	64	50	28	360	231	231.4

Fori filettati in testa secondo DIN 332
Linguette secondo UNI 6604-69

Centre holes according to DIN 332
Keys according to UNI 6604-69



ESTREMITÀ D'ALBERO

Albero cavo con linguetta

SHAFT ENDING

Hollow shaft with keyway

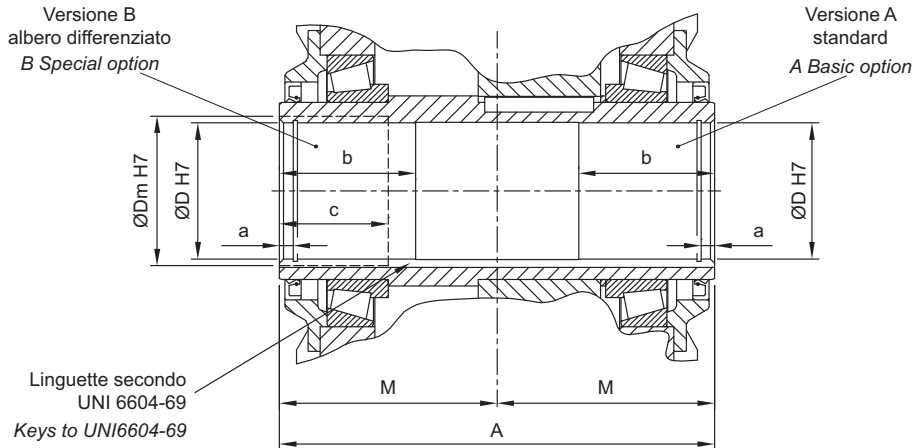

	10	20	30	40	50	60	70	80	90	100	110
A	230	270	290	320	340	380	450	500	560	620	750
D	65	80	90	100	110	120	140	160	170	200	220
Dm	70	90	100	110	120	130	155	175	185	215	235
M	115	135	145	160	170	190	225	250	280	310	375
a	7	8	9	10	11	12	14	16	18	20	22
b	65	80	90	100	110	120	140	160	170	200	220
c	56	70	80	90	100	110	125	140	160	180	200

Albero macchina

Driven machine shaft end

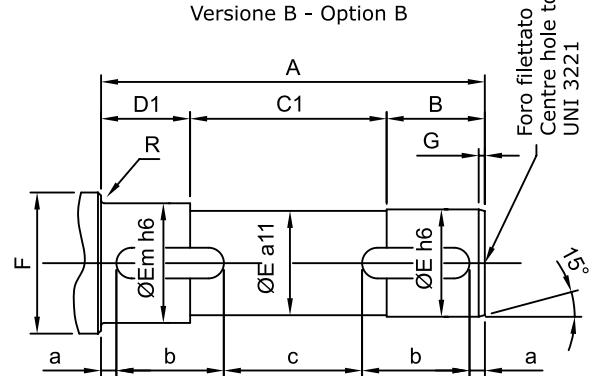
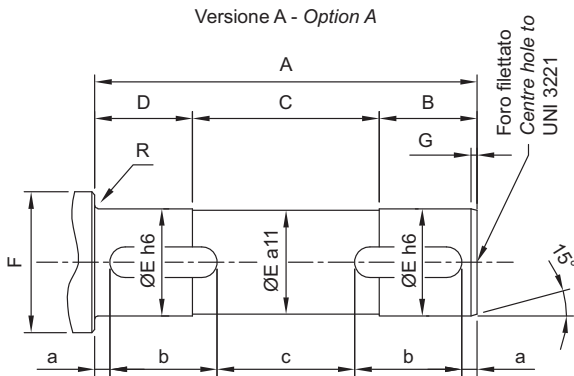

Linguette dimensionate su E in accordo con UNI 6604 - Keys dimensioned on E to UNI 6604

	10	20	30	40	50	60	70	80	90	100	110
A	212	250	265	295	310	350	415	460	515	570	695
B	50	65	70	80	85	95	110	125	130	155	170
C	97	105	105	115	115	135	165	175	215	215	305
C1	108	117	117	127	127	147	182	197	227	237	327
D	65	80	90	100	110	120	140	160	170	200	220
D1	54	68	78	88	98	108	123	138	158	178	198
E	65	80	90	100	110	120	140	160	170	200	220
Em	70	90	100	110	120	130	155	175	185	215	235
F	83	97	107	122	135	145	175	195	205	235	255
G	3	3.5	4	4.5	5	5.5	6	7	8	9	10
R	2	2.2	2.5	2.8	3	3.5	4	4.5	5	5.5	6
a	5	5	5	5	8	8	8	8	10	10	10
b	60	80	90	100	110	110	125	150	160	180	200
c	82	80	75	85	74	114	149	144	175	190	275



ESTREMITÀ D'ALBERO

Albero cavo con unità di bloccaggio

SHAFT ENDING

Hollow shaft with shrink disc

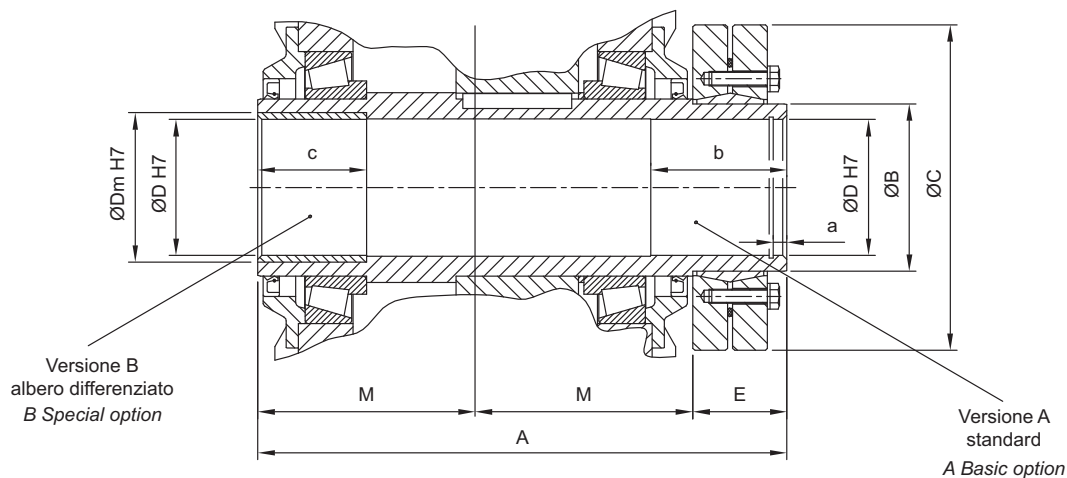

	10	20	30	40	50	60	70	80	90	100	110
A	278	333	366	396	429	476	564	614	694	770	914
B	80	100	120	130	155	165	185	200	220	260	280
C	145	170	215	215	265	290	330	350	370	430	460
D	65	80	90	100	110	120	140	160	170	200	220
Dm	70	90	100	110	120	130	155	175	185	215	235
E	48	63	76	76	89	96	114	114	134	150	164
M	115	135	145	160	170	190	225	250	280	310	375
a	7	8	9	10	11	12	14	16	18	20	22
b	65	80	90	100	110	120	140	160	170	200	220
c	56	70	80	90	100	110	125	140	160	180	200

Albero macchina

Driven machine shaft end

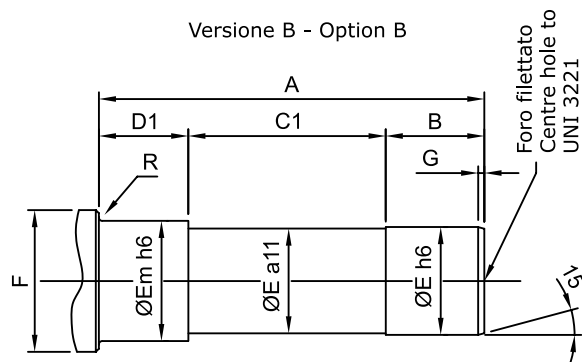
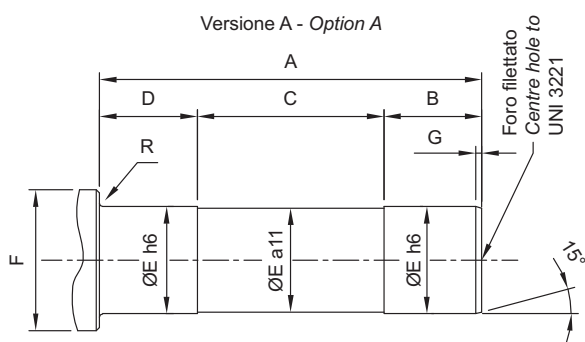

	10	20	30	40	50	60	70	80	90	100	110
A	260	313	341	371	399	446	529	574	649	720	859
B	50	65	70	80	85	95	110	125	130	155	170
C	145	168	181	191	204	231	279	289	349	365	469
C1	156	180	193	203	216	243	296	311	361	387	491
D	65	80	90	100	110	120	140	160	170	200	220
D1	54	68	78	88	98	108	123	138	158	178	198
E	65	80	90	100	110	120	140	160	170	200	220
Em	70	90	100	110	120	130	155	175	185	215	235
F	83	97	107	122	135	145	175	195	205	235	255
G	3	3.5	4	4.5	5	5.5	6	7	8	9	10
R	2	2.2	2.5	2.8	3	3.5	4	4.5	5	5.5	6



ESTREMITÀ D'ALBERO

Albero cavo con linguetta
Albero cavo con unità di bloccaggio

SHAFT ENDING

Hollow shaft with keyway
Hollow shaft with shrink disc

Montaggio
Mounting

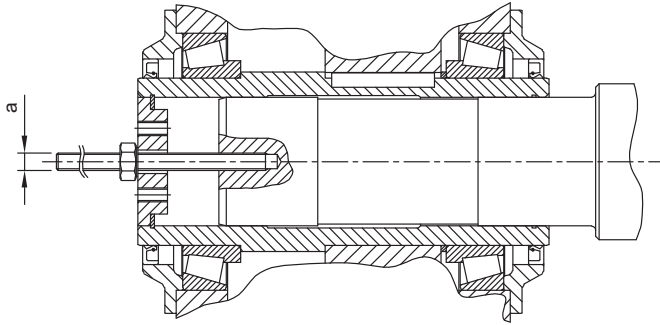

Fissaggio
Fixing

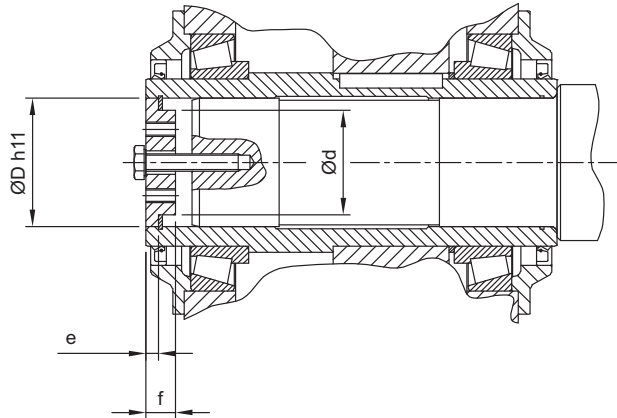

Smontaggio
Removing

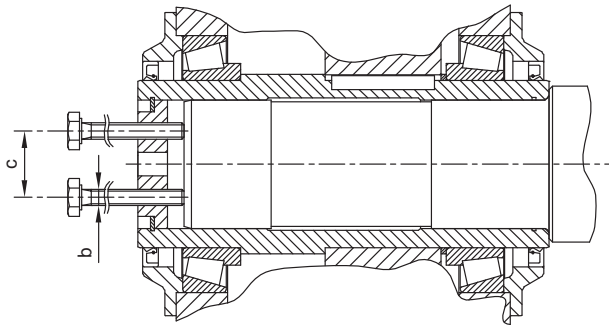

	10	20	30	40	50	60	70	80	90	100	110
a	M16	M16	M16	M20	M20	M20	M24	M24	M24	M30	M30
b	M10	M12	M14	M14	M16	M16	M18	M18	M20	M20	M24
c	37	48	55	60	65	75	95	105	115	140	155
D	65	80	90	100	110	120	140	160	170	200	220
d	52	66	74	82	90	100	120	136	148	172	190
e	7	8	9	10	11	12	14	16	18	20	22
f	16	18	20	22	25	28	32	36	40	45	50
Seeger Circlip	I 65	I 80	I 90	I 100	I 110	I 120	I 140	I 160	I 170	I 200	I 220



FLANGE DI USCITA

Le flange in uscita vengono utilizzate per collegare il riduttore direttamente alla macchina. Sono fornibili a disegno o standard B5, di cui si allegano le dimensioni.

OUTPUT FLANGES

Flanged gearbox output casing normally allows direct assembly to the driven machine. Special designs, as well as B5 standard patterns (see dimensional data sheet), are available.

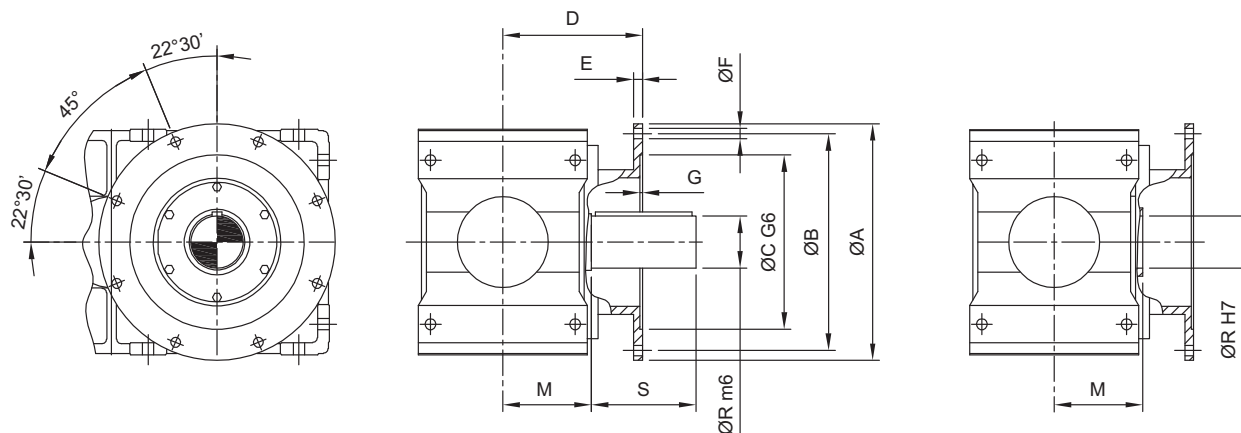

	10	20	30	40	50	60	70	80	90	100	110
A	300	300	350	400	450	550	550	660	660	SU RICHIESTA ON REQUEST	SU RICHIESTA ON REQUEST
B	265	265	300	350	400	500	500	600	600		
C	230	230	250	300	350	450	450	550	550		
D	170	185	210	225	245	270	300	350	390		
E	14	14	16	16	16	18	20	22	22		
F	18	20	22	22	24	27	30	33	36		
G	5	5	6	6	6	7	7	7	7		
M	115	135	145	160	170	190	225	250	280		
R	65	80	90	100	110	120	140	160	170		
S	110	140	160	180	200	210	250	280	300		

FISSAGGIO PENDOLARE

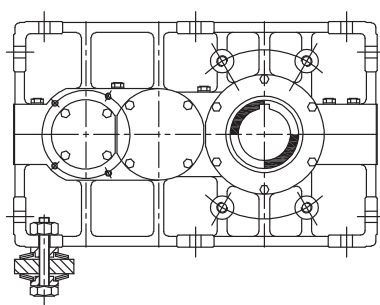

I riduttori per applicazione pendolare vengono forniti con vincolo elastico, semielastico e rigido.

SHAFT-MOUNTED APPLICATIONS

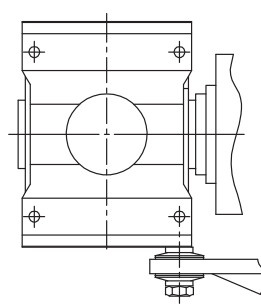

All units can be supplied with elastic constraint, semi-flexible and rigid reaction arrangement.



DISPOSITIVO ANTIRETRO

Tutti i riduttori sono fornibili con dispositivo antiretro, posizionato esternamente come indicato nelle figure sottostanti. Dettagli costruttivi vengono forniti a richiesta. In caso di ordine, specificare il senso di rotazione libera degli alberi lenti.

BACKSTOP DEVICES

Holdbacks can be fitted to all gear units. They are located externally on helical pinion shaft as shown in the diagrams below. When ordering please specify the free rotation direction of slow shafts.

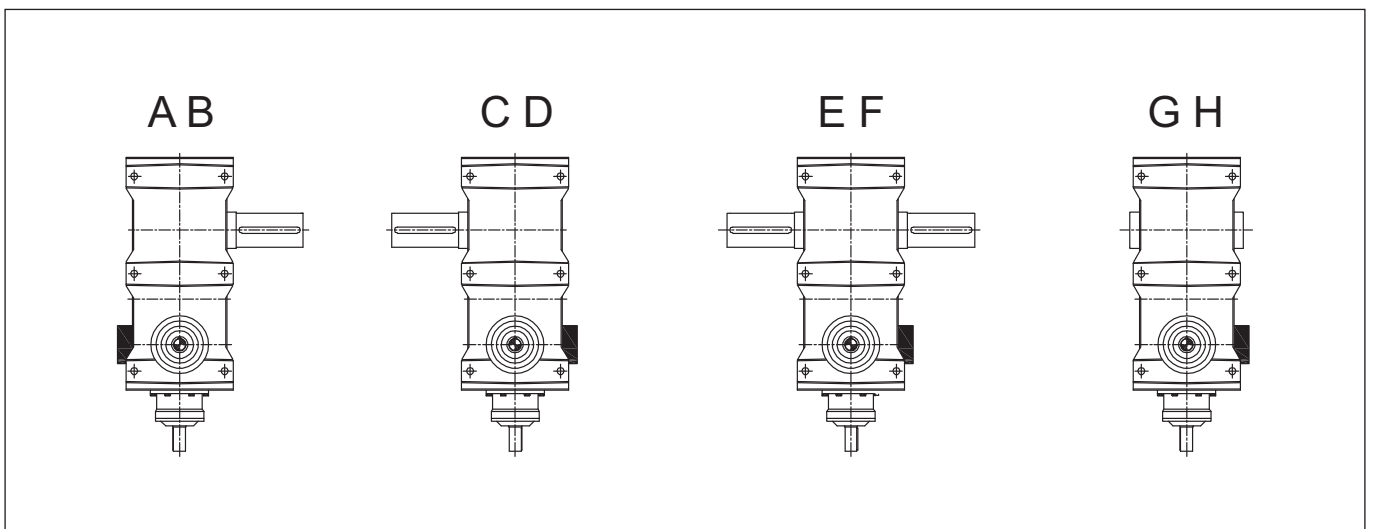
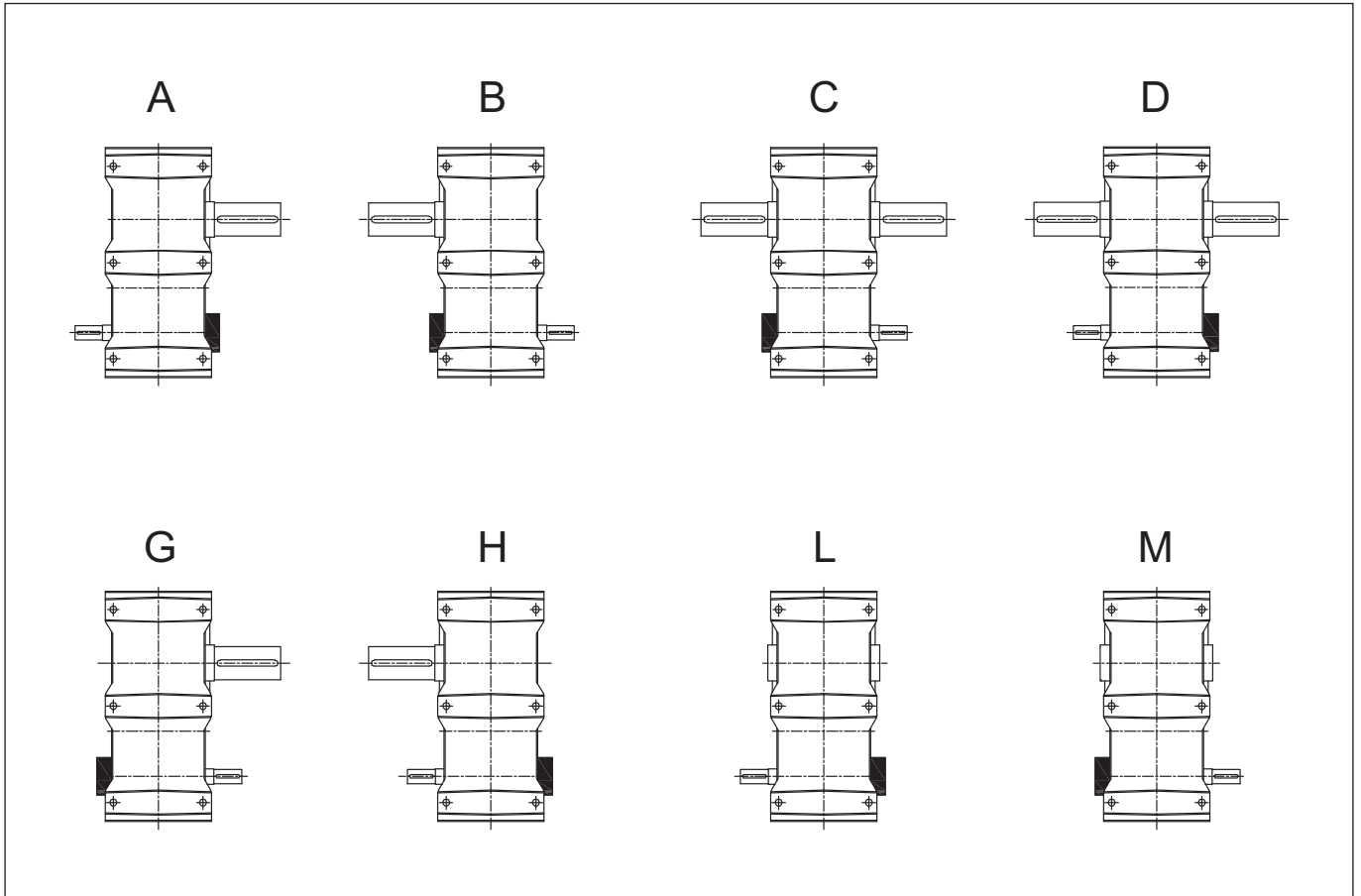



A series of horizontal lines spanning the width of the page, providing a template for text entry or notes.



CARICHI RADIALI

Qualora al riduttore vengano collegati, sia all'entrata che all'uscita, organi di trasmissione che possono produrre carichi assiali sugli alberi del riduttore stesso, è opportuno verificare che l'entità di questi carichi sia compatibile con le capacità di sopportazione del riduttore.

Nelle seguenti tabelle vengono forniti i valori massimi dei carichi radiali sull'albero veloce F_{r1} e su quello lento F_{r2} accettabili nel caso in cui il carico agisca in mezzeria dell'estremità d'albero (quota U ed S delle relative tabelle dimensionali).

Per posizione del carico a 0.25 U o S dalla battuta moltiplicare i valori indicati per 2.

Per posizione del carico a 0.75 U o S dalla battuta, moltiplicare i valori indicati per 0.67.

Qualora il carico radiale generato è inferiore al 20% dei valori indicati in tabella, non è necessaria alcuna verifica.

Contemporaneamente al carico radiale è ammissibile un **carico assiale** pari al 20% di quello radiale.

Per valori superiori, pregio contattarci.

I carichi radiali possono essere calcolati in maniera approssimativa con la seguente formula:

$$F_r = k \cdot \frac{T}{D}$$

T (Nm): momento torcente

D (mm): diametro primitivo organo calettato

I valori di k sono i seguenti:

- 2000 per trasmissione a catena
- 2100 per trasmissione ad ingranaggio
- 3000 per trasmissione a cinghia dentata
- 5000 per trasmissione a cinghia trapezoidale

MOMENTI DI INERZIA

Si riferiscono all'albero veloce del riduttore standard senza ventola di raffreddamento.

Il momento di inerzia riferito all'asse lento J_2 si ottiene dalla formula:

$$J_2 = J_1 \cdot i_r^2$$

i_r : rapporto reale



OVERHUNG LOADS

Whenever transmission components, generating radial loads, are fitted on input and output shafts, it is necessary to check that the values of such loads are compatible with the gearbox capacity.

In the following tables, maximum admissible overhung loads on high speed shaft F_{r1} and on the low speed shaft F_{r2} are shown, having as reference the load operating at the middle of the shaft ends (dimensions U and S of relevant dimensional tables).

If acting at $0.25 U$ or S from the gearbox side, multiply such values by 2.

If acting at $0.75 U$ or S from the gearbox side, multiply such values by 0.67.

When overhung load is less than 20% of admissible load shown in the table, no check is required.

Along with overhung load, a thrust load of 20% of overhung load is acceptable. For higher value, please refer to us.

Roughly overhung loads can be obtained by using the following formula:

$$F_r = k \cdot \frac{T}{D}$$

T (Nm) : torque

D (mm) : pitch circle diameter of the driving or driven component

Where k :

- 2000 for chain drive
- 2100 for gear drive
- 3000 for cog belt drive
- 5000 for V-belt drive

MASS MOMENTS OF INERTIA

The mass moments of inertia J_1 refer to the high speed shaft of a standard gearbox without fan.

The mass moments of inertia J_2 refer to the low speed shaft and are given by the following formula:

$$J_2 = J_1 \cdot i_r^2$$

i_r : actual ratio



CARICHI RADIALI F_{r1} , F_{r2}
MOMENTI DI INERZIA J_1

Riduttori ad assi paralleli PA
singolo stadio

OVERHUNG LOADS F_{r1} , F_{r2}
MASS MOMENTS OF INERTIA J_1

PA helical units – single stage

PA			10	20	30	40	50	60	70	80	90	100	110
i_N													
1.12	F_{r1}	N											
	F_{r2}	N	14400	22000	28800	35500	42700	49400	69800	85700	112900	147800	156400
	J_1	kgm ²	0.0300	0.0530	0.0941	0.1667	0.2969	0.5232	0.8987	1.6120	2.8570	4.9945	8.8947
1.25	F_{r1}	N											
	F_{r2}	N	13900	21400	27500	34600	42000	47800	68900	83200	109000	145800	153900
	J_1	kgm ²	0.0270	0.0477	0.0847	0.1502	0.2675	0.4714	0.8097	1.4523	2.5739	4.4996	8.0131
1.4	F_{r1}	N											
	F_{r2}	N	13600	20900	26600	33500	41500	47400	67900	80300	106100	143300	150300
	J_1	kgm ²	0.0243	0.0430	0.0763	0.1353	0.2410	0.4246	0.7295	1.3084	2.3188	4.0537	7.2191
1.6	F_{r1}	N											
	F_{r2}	N	13500	20800	25500	33100	40600	46000	66500	77100	104400	141300	149100
	J_1	kgm ²	0.0217	0.0383	0.0682	0.1208	0.2151	0.3792	0.6512	1.1682	2.0704	3.6194	6.4458
1.8	F_{r1}	N											
	F_{r2}	N	12600	19600	24900	32600	39800	45100	65500	75300	102200	139500	147800
	J_1	kgm ²	0.0194	0.0343	0.0608	0.1078	0.1921	0.3385	0.5815	1.0430	1.8486	3.2316	5.7552
2	F_{r1}	N	5200	6700	9200	13500	14500	22100	27900	34000	46300	55500	67900
	F_{r2}	N	12400	19200	24100	31700	39200	44100	64300	71500	100000	137300	146600
	J_1	kgm ²	0.0173	0.0306	0.0543	0.0963	0.1716	0.3023	0.5192	0.9313	1.6505	2.8853	5.1385
2.25	F_{r1}	N	5500	7000	9500	14000	15100	23100	29000	35400	48200	57800	70300
	F_{r2}	N	11800	18200	23400	31000	38300	42900	63100	67700	98100	135200	145400
	J_1	kgm ²	0.0154	0.0273	0.0484	0.0858	0.1527	0.2691	0.4622	0.8292	1.4695	2.5690	4.5751
2.5	F_{r1}	N	4400	5700	8100	11600	12600	19900	26800	31300	40100	46300	60500
	F_{r2}	N	10400	16100	21600	30100	36400	38800	56700	66000	87500	125400	144200
	J_1	kgm ²	0.0138	0.0245	0.0433	0.0770	0.1370	0.2413	0.4146	0.7437	1.3180	2.3041	4.1034
2.8	F_{r1}	N	4600	5900	8300	12000	13100	20700	27800	32500	41600	48100	62800
	F_{r2}	N	10400	16100	21600	30100	36400	38800	56700	66000	87500	125400	144200
	J_1	kgm ²	0.0123	0.0217	0.0384	0.0681	0.1081	0.2136	0.3670	0.6582	1.1665	2.0393	3.6317
3.15	F_{r1}	N	4800	6100	8600	12500	13600	21500	28800	33800	43200	49900	64000
	F_{r2}	N	10400	16100	21600	30100	36400	38800	56700	66000	87500	125400	144200
	J_1	kgm ²	0.0109	0.0194	0.0344	0.0610	0.1087	0.1914	0.3288	0.5898	1.0453	1.8274	3.2545
3.55	F_{r1}	N	4900	6300	8900	13000	14100	22300	29800	35000	44800	51700	65000
	F_{r2}	N	10400	16100	21600	30100	36400	38800	56700	66000	87500	125400	144200
	J_1	kgm ²	0.0095	0.0169	0.0299	0.0530	0.0945	0.1665	0.2863	0.5129	0.9090	1.5891	2.8300
4	F_{r1}	N	5100	6400	9100	13500	14600	23100	30800	36200	46400	53500	66000
	F_{r2}	N	8800	14200	19400	24500	35000	37600	53400	53300	79400	118300	125800
	J_1	kgm ²	0.0082	0.0146	0.0260	0.0460	0.0819	0.1443	0.2479	0.4445	0.7878	1.3772	2.4527
4.5	F_{r1}	N	5200	6700	9500	13800	15100	23800	31900	37400	48000	55300	66500
	F_{r2}	N	10400	16100	21800	27200	30400	33400	48100	59800	82800	110300	123400
	J_1	kgm ²	0.0072	0.0127	0.0225	0.0398	0.0708	0.1248	0.2145	0.3846	0.6817	1.1918	2.1224
5	F_{r1}	N	5400	6900	9800	14300	15600	24600	32900	38700	49600	57100	68200
	F_{r2}	N	11700	18000	24500	30000	35000	38200	55700	67300	93000	121200	128300
	J_1	kgm ²	0.0062	0.0110	0.0195	0.0345	0.0614	0.1082	0.1858	0.3334	0.5908	1.0328	1.8394
5.6	F_{r1}	N	5600	7100	10000	14800	16100	25400	33900	39900	51200	58900	69400
	F_{r2}	N	13000	20000	26700	32300	38100	42900	61300	74800	101100	130300	142900
	J_1	kgm ²	0.0054	0.0096	0.0170	0.0300	0.0536	0.0944	0.1621	0.2906	0.5151	0.9005	1.6037



CARICHI RADIALI F_{r1} , F_{r2}
MOMENTI DI INERZIA J_1

Riduttori ad assi paralleli PB
 due stadi

OVERHUNG LOADS F_{r1} , F_{r2}
MASS MOMENTS OF INERTIA J_1

PB helical units – double stage

PB			10	20	30	40	50	60	70	80	90	100	110
i_N													
6.3	F_{r1}	N	4400	5600	6800	9100	9900	11500	18500	20600	29300	34400	43100
	F_{r2}	N	10100	15700	22800	23300	28400	36900	48700	59800	82200	108200	123400
	J_1	kgm ²	0.0118	0.0211	0.0376	0.0665	0.1187	0.2135	0.3738	0.6661	1.1922	2.1014	3.7540
7.1	F_{r1}	N	4500	5800	7000	9300	10300	12000	18800	21500	30200	35500	44600
	F_{r2}	N	12700	19700	22800	29200	32800	43000	57100	67500	97100	128400	147700
	J_1	kgm ²	0.0103	0.0184	0.0330	0.0582	0.1040	0.1870	0.3274	0.5836	1.0444	1.8407	3.2884
8	F_{r1}	N	4600	6000	7100	9500	10700	12500	19200	22300	31200	36600	46100
	F_{r2}	N	12700	19700	22500	29200	31000	40200	52900	65300	90900	120700	140000
	J_1	kgm ²	0.0091	0.0161	0.0289	0.0510	0.0911	0.1638	0.2868	0.5111	0.9149	1.6125	2.8805
9	F_{r1}	N	4700	6200	7300	9700	11100	13000	19500	23200	32100	37700	47300
	F_{r2}	N	12100	19200	22500	28200	30400	37400	47700	58200	84800	114400	130700
	J_1	kgm ²	0.0079	0.0140	0.0250	0.0443	0.0791	0.1421	0.2488	0.4435	0.7936	1.3989	2.4990
10	F_{r1}	N	4800	6300	7200	9900	11500	13500	19900	24100	33100	38800	49100
	F_{r2}	N	12100	19200	22500	28200	30400	36600	45900	56700	84800	114400	123500
	J_1	kgm ²	0.0068	0.0120	0.0214	0.0379	0.0677	0.1216	0.2129	0.3794	0.6790	1.1967	2.1378
11.2	F_{r1}	N	4900	6581	7700	10100	11900	14000	20200	24900	34100	39900	50600
	F_{r2}	N	12100	19200	21900	28200	30400	36600	45900	56700	84800	114400	123500
	J_1	kgm ²	0.0058	0.0102	0.0182	0.0322	0.0577	0.1035	0.1812	0.3229	0.5779	1.0186	1.8196
12.5	F_{r1}	N	4200	5900	7200	8000	9800	11800	16200	20600	28800	36400	44200
	F_{r2}	N	11500	18500	21900	27200	29800	35700	44700	54600	83500	110000	120000
	J_1	kgm ²	0.0048	0.0085	0.0152	0.0269	0.0480	0.0864	0.1512	0.2696	0.4824	0.8502	1.5189
14	F_{r1}	N	4300	6000	7300	8300	10100	12200	16500	21300	29600	37400	45500
	F_{r2}	N	11500	18500	21900	27200	29800	35700	44700	54600	83500	110000	120800
	J_1	kgm ²	0.0041	0.0073	0.0130	0.0234	0.0410	0.0739	0.1294	0.2305	0.4126	0.7272	1.2992
16	F_{r1}	N	4400	6200	7500	8500	10400	12200	16700	22000	30400	38400	46800
	F_{r2}	N	11500	18500	24300	27200	29800	35700	44600	54600	83500	110000	120800
	J_1	kgm ²	0.0035	0.0063	0.0113	0.0199	0.0356	0.0639	0.1119	0.1995	0.3571	0.6293	1.1243
18	F_{r1}	N	4500	6400	7600	8700	10800	13000	17000	22700	31200	39300	48100
	F_{r2}	N	12800	20500	24300	31000	33200	39400	48900	59100	93100	123900	135700
	J_1	kgm ²	0.0032	0.0055	0.0099	0.0172	0.0312	0.0561	0.0982	0.1750	0.3132	0.5521	0.9863
20	F_{r1}	N	4500	6400	7800	9000	11100	13400	17300	23300	32000	40300	49300
	F_{r2}	N	12800	20500	23200	31000	33200	39400	48900	59100	93100	123900	135700
	J_1	kgm ²	0.0028	0.0049	0.0088	0.0155	0.0277	0.0499	0.0873	0.1555	0.2784	0.4906	0.8764
22.5	F_{r1}	N			8000			13800	17700	24000	32700	41400	50700
	F_{r2}	N			20700			38200	47300	53500	92000	117800	131200
	J_1	kgm ²			0.0076			0.0430	0.0753	0.1341	0.2401	0.4232	0.7560
25	F_{r1}	N											51300
	F_{r2}	N											132600
	J_1	kgm ²											0.6853



CARICHI RADIALI F_{r1} , F_{r2}
MOMENTI DI INERZIA J_1

Riduttori ad assi paralleli PC
 tre stadi

OVERHUNG LOADS F_{r1} , F_{r2}
MASS MOMENTS OF INERTIA J_1

PC helical units – triple stage

PC			10	20	30	40	50	60	70	80	90	100	110
i_N													
22.5	F_{r1}	N	2000	2700		6100	8300						
	F_{r2}	N	13000	18200		42200	52800						
	J_1	kgm ²	0.0007	0.0017		0.0055	0.0103						
25	F_{r1}	N	2000	2700	5400	6100	8300	9700	12600	15200	17500	27500	40800
	F_{r2}	N	13000	18200	23600	42200	52800	57800	70500	85500	93500	166600	229000
	J_1	kgm ²	0.0007	0.0016	0.0026	0.0053	0.0097	0.0156	0.0263	0.0477	0.0910	0.1527	0.4993
28	F_{r1}	N	2100	2800	5500	6200	8400	9800	12600	15300	17600	27700	33700
	F_{r2}	N	13000	18200	23600	42200	52800	57800	70500	85600	93500	166600	206800
	J_1	kgm ²	0.0007	0.0015	0.0025	0.0050	0.0086	0.0150	0.0257	0.0473	0.0860	0.1517	0.2704
31.5	F_{r1}	N	2100	2800	5500	6200	8400	9800	12600	15400	17800	27900	33800
	F_{r2}	N	13000	18200	23600	42200	52800	57800	70500	85600	93500	166600	206800
	J_1	kgm ²	0.0007	0.0014	0.0024	0.0046	0.0081	0.0142	0.0245	0.0447	0.0809	0.1428	0.2547
35.5	F_{r1}	N	2100	2800	5500	6200	8400	9900	12700	15400	17900	28000	33900
	F_{r2}	N	12400	17700	22500	40000	50600	55600	67200	82200	88100	161100	200200
	J_1	kgm ²	0.0007	0.0013	0.0024	0.0043	0.0076	0.0134	0.0237	0.0422	0.0761	0.1345	0.2399
40	F_{r1}	N	2100	2800	5500	6200	8400	9900	12700	15500	17900	28000	34000
	F_{r2}	N	12400	17700	22500	40000	50600	55600	67200	82200	88100	161100	200200
	J_1	kgm ²	0.0007	0.0012	0.0023	0.0040	0.0071	0.0127	0.0223	0.0399	0.0716	0.1266	0.2260
45	F_{r1}	N	2200	2900	5600	6300	8500	9900	12700	15500	18000	28100	34100
	F_{r2}	N	12400	17700	22500	40000	50600	55600	67200	82200	88100	161100	200200
	J_1	kgm ²	0.0006	0.0012	0.0022	0.0038	0.0068	0.0119	0.0210	0.0377	0.0674	0.1192	0.2129
50	F_{r1}	N	2200	2900	5600	6300	8500	10000	12800	15600	18000	28200	34200
	F_{r2}	N	11900	17100	21300	37700	48400	53400	64900	79900	85000	157700	195800
	J_1	kgm ²	0.0006	0.0011	0.0020	0.0036	0.0063	0.0113	0.0198	0.0354	0.0635	0.1123	0.2005
56	F_{r1}	N	2200	2900	5600	6300	8500	10000	12800	15600	18100	28300	34300
	F_{r2}	N	11900	17100	21300	37700	48400	53400	64900	79900	85000	157700	195800
	J_1	kgm ²	0.0005	0.0010	0.0019	0.0034	0.0059	0.0106	0.0187	0.0334	0.0597	0.1056	0.1885
63	F_{r1}	N	2200	2900	5600	6300	8500	10000	12800	15700	18200	28400	34400
	F_{r2}	N	11900	17100	21300	37700	48400	53400	64900	79900	85000	157700	195800
	J_1	kgm ²	0.0005	0.0010	0.0018	0.0032	0.0056	0.0101	0.0177	0.0315	0.0564	0.0998	0.1783
71	F_{r1}	N	2300	3000	5600	6300	8600	10100	12900	15700	18200	28500	34500
	F_{r2}	N	11900	17100	21300	37700	48400	53400	64900	79900	85000	157700	195800
	J_1	kgm ²	0.0005	0.0009	0.0017	0.0030	0.0054	0.0095	0.0166	0.0298	0.0533	0.0943	0.1684
80	F_{r1}	N	2300	3000	5600	6300	8600	10100	12900	15800	18300	28600	34500
	F_{r2}	N	11900	17100	21300	37700	48400	53400	64900	79900	85000	157700	195800
	J_1	kgm ²	0.0004	0.0009	0.0016	0.0029	0.0051	0.0091	0.0160	0.0285	0.0511	0.0904	0.1613
90	F_{r1}	N	2300	3000	5600	6300	8600	10200	13000	15800	18400	28700	34600
	F_{r2}	N	11900	17100	21300	37700	48400	53400	64900	79900	85000	157700	195800
	J_1	kgm ²	0.0004	0.0008	0.0016	0.0027	0.0049	0.0087	0.0153	0.0275	0.0492	0.0871	0.1555
100	F_{r1}	N	2300	3000	5600	6300	10200	13000	15900	18400	28700	34700	41900
	F_{r2}	N	11900	17100	21300	37700	53400	64900	79900	85000	157700	195800	218100
	J_1	kgm ²	0.0004	0.0008	0.0015	0.0027	0.0085	0.0150	0.0267	0.0478	0.0847	0.1512	0.2689



CARICHI RADIALI F_{r1} , F_{r2}
MOMENTI DI INERZIA J_1

Riduttori ad assi paralleli PD
 quattro stadi

OVERHUNG LOADS F_{r1} , F_{r2}
MASS MOMENTS OF INERTIA J_1

PD helical units – quadruple stage

PD			10	20	30	40	50	60	70	80	90	100	110
i_N													
100	F_{r1}	N					8800						
	F_{r2}	N					62700						
	J_1	kgm ²					0.0028						
112	F_{r1}	N	1900	3200	5700	6400	8800	9800	12400	15600	17500	23800	28400
	F_{r2}	N	18600	27500	39800	48300	62700	76700	94400	108500	164600	197900	224500
	J_1	kgm ²	0.0003	0.0005	0.0009	0.0016	0.0028	0.0049	0.0086	0.0152	0.0258	0.0488	0.0862
125	F_{r1}	N	1900	3200	5700	6400	8800	9800	12400	15600	17500	23800	28400
	F_{r2}	N	18600	27500	39800	48300	62700	76700	94400	108500	164600	197900	224500
	J_1	kgm ²	0.0003	0.0005	0.0009	0.0016	0.0028	0.0049	0.0086	0.0152	0.0258	0.0488	0.0862
140	F_{r1}	N	1900	3200	5700	6400	8800	9800	12400	15600	17500	23800	28400
	F_{r2}	N	18600	27500	39800	48300	62700	76700	94400	108500	164600	197900	224500
	J_1	kgm ²	0.0003	0.0005	0.0009	0.0016	0.0028	0.0049	0.0086	0.0152	0.0258	0.0488	0.0862
160	F_{r1}	N	1900	3200	5700	6400	8800	9800	12400	15600	17500	23800	28400
	F_{r2}	N	18600	27500	39800	48300	62700	76700	94400	108500	164600	197900	224500
	J_1	kgm ²	0.0003	0.0005	0.0009	0.0016	0.0028	0.0049	0.0086	0.0152	0.0258	0.0488	0.0862
180	F_{r1}	N	2000	3300	5800	6500	8900	10000	12500	15800	17700	24200	28800
	F_{r2}	N	18800	27800	40200	48900	63400	77600	95400	109800	166500	200200	227100
	J_1	kgm ²	0.0003	0.0005	0.0009	0.0016	0.0028	0.0049	0.0086	0.0152	0.0258	0.0488	0.0862
200	F_{r1}	N	2000	3300	5800	6500	8900	10000	12500	15800	17700	24200	28800
	F_{r2}	N	18800	27800	40200	48900	63400	77600	95400	109800	166500	200200	227100
	J_1	kgm ²	0.0002	0.0004	0.0008	0.0014	0.0025	0.0042	0.0078	0.0141	0.0238	0.0466	0.0835
225	F_{r1}	N	2000	3300	5800	6500	8900	10000	12500	15800	17700	24200	28800
	F_{r2}	N	18800	27800	40200	48900	63400	77600	95400	109800	166500	200200	227100
	J_1	kgm ²	0.0002	0.0004	0.0008	0.0014	0.0025	0.0042	0.0078	0.0141	0.0238	0.0466	0.0835
250	F_{r1}	N	2000	3300	5800	6500	8900	10000	12500	15800	17700	24200	28800
	F_{r2}	N	18800	27800	40200	48900	63400	77600	95400	109800	166500	200200	227100
	J_1	kgm ²	0.0002	0.0004	0.0008	0.0014	0.0025	0.0042	0.0078	0.0141	0.0238	0.0466	0.0835
280	F_{r1}	N	2100	3400	5900	6600	9000	10200	12700	16000	18000	24500	29100
	F_{r2}	N	19000	28100	40700	49500	64100	78500	96500	111100	168400	202500	229700
	J_1	kgm ²	0.0002	0.0004	0.0008	0.0014	0.0025	0.0042	0.0078	0.0141	0.0238	0.0466	0.0835
315	F_{r1}	N	2100	3400	5900	6600	9000	10200	12700	16000	18000	24500	29100
	F_{r2}	N	19000	28100	40700	49500	64100	78500	96500	111100	168400	202500	229700
	J_1	kgm ²	0.0002	0.0004	0.0008	0.0014	0.0025	0.0042	0.0078	0.0141	0.0238	0.0466	0.0835
355	F_{r1}	N	2100	3400	5900	6600	9000	10200	12700	16000	18000	24500	29100
	F_{r2}	N	19000	28100	40700	49500	64100	78500	96500	111100	168400	202500	229700
	J_1	kgm ²	0.0002	0.0004	0.0008	0.0014	0.0025	0.0042	0.0078	0.0141	0.0238	0.0466	0.0835
400	F_{r1}	N	2100	3400	5900	6600	9000	10200	12700	16000	18000	24500	29100
	F_{r2}	N	19000	28100	40700	49500	64100	78500	96500	111100	168400	202500	229700
	J_1	kgm ²	0.0002	0.0004	0.0008	0.0014	0.0025	0.0042	0.0078	0.0141	0.0238	0.0466	0.0835
450	F_{r1}	N	2200	3500	6000	6700	9100	10300	12900	16300	18200	24800	29500
	F_{r2}	N	19200	28400	41200	5000	64900	79400	97600	112300	170300	204800	232300
	J_1	kgm ²	0.0002	0.0004	0.0008	0.0014	0.0025	0.0042	0.0078	0.0141	0.0238	0.0466	0.0835
500	F_{r1}	N	2200	3500	6000	6700	9100	10300	12900	16300	18200	24800	29500
	F_{r2}	N	19200	28400	41200	5000	64900	79400	97600	112300	170300	204800	232300
	J_1	kgm ²	0.0002	0.0004	0.0008	0.0014	0.0025	0.0042	0.0078	0.0141	0.0238	0.0466	0.0835



CARICHI RADIALI F_{r1} , F_{r2}
MOMENTI DI INERZIA J_1

Riduttori ad assi ortogonali
 RHB/RVB due stadi

OVERHUNG LOADS F_{r1} , F_{r2}
MASS MOMENTS OF INERTIA J_1

RHB/RVB bevel-helical units – double stage

RHB/RVB			10	20	30	40	50	60	70	80	90	100	110
i_N													
5	F_{r1}	N	4100	5300	7800	9200	11500	12400	14300	22400	33100	42500	52000
	F_{r2}	N	14200	18600	24800	30600	37000	44700	60800	77800	102700	131000	144000
	J_1	kgm ²	0.0036	0.0062	0.0111	0.0199	0.0357	0.0634	0.1097	0.1990	0.3663	0.6611	1.1745
5.6	F_{r1}	N	4300	5500	8200	9700	12100	13000	15000	23600	34900	44800	54800
	F_{r2}	N	13300	17400	23500	29200	35300	42700	58200	74700	100300	128400	141000
	J_1	kgm ²	0.0035	0.0059	0.0106	0.0188	0.0339	0.0602	0.1042	0.1890	0.3480	0.6279	1.1154
6.3	F_{r1}	N	4500	5800	8600	10200	12800	13700	15800	24800	36600	47000	57500
	F_{r2}	N	12500	16800	22800	28200	33000	40200	56600	72600	97300	124700	137000
	J_1	kgm ²	0.0033	0.0056	0.0100	0.0179	0.0322	0.0572	0.0990	0.1795	0.3305	0.5962	1.0592
7.1	F_{r1}	N	4800	6100	9000	10700	13400	14300	16500	26000	38400	49300	60200
	F_{r2}	N	14100	18500	25700	31800	36600	48100	65400	83900	93200	142000	156100
	J_1	kgm ²	0.0031	0.0054	0.0096	0.0173	0.0311	0.0553	0.0956	0.1733	0.3192	0.5662	1.0059
8	F_{r1}	N	5000	6400	9400	11200	14000	15000	17300	27100	40100	51500	63000
	F_{r2}	N	10900	14200	32500	26500	34600	42200	60000	73300	107800	126800	139300
	J_1	kgm ²	0.0030	0.0051	0.0092	0.0163	0.0294	0.0522	0.0903	0.1638	0.3015	0.5467	0.9713
9	F_{r1}	N	5200	6700	9900	11700	14600	15600	18100	28300	41900	53800	65700
	F_{r2}	N	11100	14500	21600	22300	33200	40100	58100	71400	95400	131400	144300
	J_1	kgm ²	0.0029	0.0049	0.0087	0.0155	0.0278	0.0495	0.0856	0.1552	0.2859	0.5167	0.9179
10	F_{r1}	N	5400	6900	10300	12200	15200	16300	18800	29500	43600	56000	68500
	F_{r2}	N	11300	13200	20800	25100	30000	38800	56600	69900	86400	124900	137300
	J_1	kgm ²	0.0027	0.0046	0.0083	0.0148	0.0266	0.0473	0.0819	0.1486	0.2735	0.4897	0.8700
11.2	F_{r1}	N	5600	7200	10700	12700	15800	16900	19600	30700	45300	58200	71200
	F_{r2}	N	13000	15400	21900	28100	30900	34900	56400	69100	86100	123600	135800
	J_1	kgm ²	0.0026	0.0045	0.0080	0.0143	0.0258	0.0459	0.0793	0.1438	0.2648	0.4686	0.8325
12.5	F_{r1}	N	5400	6600	9900	11800	14900	16100	17400	27900	41900	55400	67200
	F_{r2}	N	16400	21400	31000	38200	44800	48400	69900	86200	84600	155300	170600
	J_1	kgm ²	0.0025	0.0042	0.0076	0.0135	0.0243	0.0431	0.0746	0.1352	0.2490	0.4536	0.8059
14	F_{r1}	N	5600	6800	10200	12300	15500	16700	18100	28900	43400	56400	69700
	F_{r2}	N	17900	23500	32900	40400	46000	53400	75500	96300	119300	166400	182800
	J_1	kgm ²	0.0023	0.0041	0.0074	0.0132	0.0237	0.0422	0.0730	0.1324	0.2438	0.4266	0.7578
16	F_{r1}	N	6200	7500	11300	13600	17100	18500	20000	32000	48100	62500	77200
	F_{r2}	N	16200	21400	28900	37300	44800	49300	65600	84400	126500	161000	176900
	J_1	kgm ²	0.0023	0.0039	0.0071	0.0127	0.0228	0.0407	0.0704	0.1276	0.2350	0.4176	0.7419
18	F_{r1}	N	6300	7700	11500	13800	17400	18800	20300	32500	48800	63500	78400
	F_{r2}	N	15600	20600	30300	36300	43500	45600	67700	82900	124300	163600	179700
	J_1	kgm ²	0.0022	0.0038	0.0070	0.0124	0.0214	0.0397	0.0688	0.1248	0.2298	0.4026	0.7152



CARICHI RADIALI F_{r1} , F_{r2}
MOMENTI DI INERZIA J_1

Riduttori ad assi ortogonali
 RHC/RVC tre stadi

OVERHUNG LOADS F_{r1} , F_{r2}
MASS MOMENTS OF INERTIA J_1

RHC/RVC bevel-helical units – triple stage

RHC/RVC			10	20	30	40	50	60	70	80	90	100	110
i_N													
20	F_{r1}	N	2000	3600	6900	7400	9900	11700	14600	17100	19600	28800	33200
	F_{r2}	N	11300	13700	21200	27500	29900	35700	43100	54000	79500	114400	129600
	J_1	kgm ²	0.0025	0.0044	0.0073	0.0131	0.0238	0.0426	0.0744	0.1326	0.2375	0.4187	0.7474
22.5	F_{r1}	N	2000	3600	6900	7400	9900	11800	14700	17200	19900	29000	33400
	F_{r2}	N	11300	13700	21200	27500	29900	35700	43100	54000	79500	114400	129600
	J_1	kgm ²	0.0024	0.0040	0.0069	0.0123	0.0222	0.0397	0.0694	0.1238	0.2216	0.3907	0.6976
25	F_{r1}	N	2000	3600	6900	7400	10000	11900	14800	17400	20100	29200	33600
	F_{r2}	N	10100	12200	20300	26000	28200	33700	40600	50900	75000	108000	122300
	J_1	kgm ²	0.0021	0.0037	0.0064	0.0116	0.0207	0.0371	0.0648	0.1155	0.2068	0.3646	0.6511
28	F_{r1}	N	2200	3700	7000	7500	10000	12100	14900	17600	20300	29400	33800
	F_{r2}	N	10100	12200	20300	26000	28200	33700	40600	50900	75000	108000	122300
	J_1	kgm ²	0.0019	0.0034	0.0061	0.0108	0.0193	0.0346	0.0605	0.1078	0.1930	0.3402	0.6077
31.5	F_{r1}	N	2200	3700	7000	7500	10100	12200	15000	17800	20400	29700	34100
	F_{r2}	N	10100	12200	20300	26000	28200	33600	40600	50900	75000	108000	122300
	J_1	kgm ²	0.0018	0.0032	0.0057	0.0101	0.0179	0.0323	0.0565	0.1006	0.1801	0.3175	0.5671
35.5	F_{r1}	N	2200	3700	7000	7500	10100	12300	15100	17900	20600	29700	34300
	F_{r2}	N	9500	11700	19800	24500	26600	31800	38400	48100	70900	102000	115500
	J_1	kgm ²	0.0017	0.0030	0.0053	0.0094	0.0167	0.0301	0.0530	0.0939	0.1681	0.2963	0.5293
40	F_{r1}	N	2200	3700	7000	7500	10200	12400	15200	18100	20900	30100	34500
	F_{r2}	N	9500	11700	19800	24500	26600	31800	38400	48100	70900	102000	115500
	J_1	kgm ²	0.0016	0.0028	0.0049	0.0088	0.0156	0.0281	0.0492	0.0877	0.1569	0.2766	0.4941
45	F_{r1}	N	2300	3800	7100	7700	10200	12500	15400	18200	21100	30300	34700
	F_{r2}	N	9500	11700	19800	24500	26600	31800	38400	48100	70900	102000	115500
	J_1	kgm ²	0.0015	0.0026	0.0047	0.0081	0.0146	0.0262	0.0460	0.0818	0.1465	0.2581	0.4611
50	F_{r1}	N	1900	3100	5800	6400	8400	10300	12600	15200	17600	25300	28600
	F_{r2}	N	7900	11300	19200	23600	25600	30700	37000	46300	68300	98300	111300
	J_1	kgm ²	0.0014	0.0025	0.0043	0.0076	0.0136	0.0244	0.0428	0.0763	0.1365	0.2406	0.4298
56	F_{r1}	N	1900	3100	5800	6400	8400	10400	12700	15300	17800	25500	28800
	F_{r2}	N	7900	11300	19200	23600	25600	30700	37000	46300	68300	98300	111300
	J_1	kgm ²	0.0012	0.0023	0.0040	0.0071	0.0126	0.0227	0.0397	0.0707	0.1266	0.2231	0.3986
63	F_{r1}	N	1900	3100	5800	6400	8500	10500	12800	15500	18000	25700	28900
	F_{r2}	N	7900	11300	19200	23600	25600	30700	37000	46300	68300	98300	111300
	J_1	kgm ²	0.0011	0.0021	0.0037	0.0065	0.0116	0.0209	0.0366	0.0652	0.1167	0.2056	0.3673
71	F_{r1}	N	2000	3200	5900	6400	8500	10600	12900	15600	18200	25900	29100
	F_{r2}	N	7400	10800	18500	22600	24600	29400	35400	44400	65400	94100	106600
	J_1	kgm ²	0.0011	0.0019	0.0033	0.0060	0.0106	0.0191	0.0334	0.0596	0.1067	0.1881	0.3360
80	F_{r1}	N		3200		6400	8600	10700	13000	15800	18300	26000	29300
	F_{r2}	N		10800		22600	24600	29400	35400	44400	65400	94100	106600
	J_1	kgm ²		0.0018		0.0057	0.0134	0.0182	0.0319	0.0568	0.1018	0.1794	0.3205



CARICHI RADIALI F_{r1} , F_{r2}
MOMENTI DI INERZIA J_1

Riduttori ad assi ortogonali
 RHD/RVD quattro stadi

OVERHUNG LOADS F_{r1} , F_{r2}
MASS MOMENTS OF INERTIA J_1

RHD/RVD bevel-helical units – quadruple stage

RHD/RVD			10	20	30	40	50	60	70	80	90	100	110
i_N													
80	F_{r1}	N	1900		3200								
	F_{r2}	N	4100		9600								
	J_1	kgm ²	0.0001		0.0007								
90	F_{r1}	N	1900	2400	3200	3900	5300	6400	11900	14900	17700	19300	23100
	F_{r2}	N	4100	5200	9600	14400	20000	25700	31900	37600	46100	50400	60700
	J_1	kgm ²	0.0001	0.0005	0.0007	0.0009	0.0018	0.0029	0.0051	0.0096	0.0177	0.0311	0.0501
100	F_{r1}	N	1900	2400	3200	3900	5300	6400	11900	14900	17700	19300	23100
	F_{r2}	N	4100	5200	9600	14400	20000	25700	31900	37600	46100	50400	60700
	J_1	kgm ²	0.0001	0.0005	0.0007	0.0009	0.0018	0.0029	0.0051	0.0096	0.0177	0.0311	0.0501
112	F_{r1}	N	1900	2400	3200	3900	5300	6400	11900	14900	17700	19300	23100
	F_{r2}	N	4100	5200	9600	14400	20000	25700	31900	37600	46100	50400	60700
	J_1	kgm ²	0.0001	0.0005	0.0007	0.0009	0.0018	0.0029	0.0051	0.0096	0.0177	0.0311	0.0501
125	F_{r1}	N	1900	2400	3200	3900	5300	6400	11900	14900	17700	19300	23100
	F_{r2}	N	4100	5200	9600	14400	20000	25700	31900	37600	46100	50400	60700
	J_1	kgm ²	0.0001	0.0005	0.0007	0.0009	0.0018	0.0029	0.0051	0.0096	0.0177	0.0311	0.0501
140	F_{r1}	N	1900	2400	3200	3900	5300	6400	11900	14900	17700	19300	23100
	F_{r2}	N	4100	5200	9600	14400	20000	25700	31900	37600	46100	50400	60700
	J_1	kgm ²	0.0001	0.0005	0.0007	0.0009	0.0018	0.0029	0.0051	0.0096	0.0177	0.0311	0.0501
160	F_{r1}	N	1900	2400	3200	3900	5300	6400	11900	14900	17700	19300	23100
	F_{r2}	N	4100	5200	9600	14400	20000	25700	31900	37600	46100	50400	60700
	J_1	kgm ²	0.0001	0.0005	0.0007	0.0009	0.0018	0.0029	0.0051	0.0096	0.0177	0.0311	0.0501
180	F_{r1}	N	1900	2400	3200	3900	5300	6400	11900	14900	17700	19300	23100
	F_{r2}	N	4100	5200	9600	14400	20000	25700	31900	37600	46100	50400	60700
	J_1	kgm ²	0.0001	0.0005	0.0007	0.0009	0.0018	0.0029	0.0051	0.0096	0.0177	0.0311	0.0501
200	F_{r1}	N	1900	2400	3200	3900	5300	6400	11900	14900	17700	19300	23100
	F_{r2}	N	4100	5200	9600	14400	20000	25700	31900	37600	46100	50400	60700
	J_1	kgm ²	0.0001	0.0005	0.0007	0.0009	0.0018	0.0029	0.0051	0.0096	0.0177	0.0311	0.0501
225	F_{r1}	N	1900	2400	3200	3900	5300	6400	11900	14900	17700	19300	23100
	F_{r2}	N	4100	5200	9600	14400	20000	25700	31900	37600	46100	50400	60700
	J_1	kgm ²	0.0001	0.0005	0.0007	0.0009	0.0018	0.0029	0.0051	0.0096	0.0177	0.0311	0.0501
250	F_{r1}	N	1600	2200	2900	3600	4500	5600	10900	13400	16100	17700	19800
	F_{r2}	N	4100	5200	9600	14400	20000	25700	31900	37600	46100	50400	60700
	J_1	kgm ²	0.0001	0.0005	0.0007	0.0009	0.0018	0.0029	0.0051	0.0096	0.0177	0.0311	0.0501
280	F_{r1}	N	1600	2200	2900	3600	4500	5600	10900	13400	16100	17700	19800
	F_{r2}	N	4100	5200	9600	14400	20000	25700	31900	37600	46100	50400	60700
	J_1	kgm ²	0.0001	0.0005	0.0007	0.0009	0.0018	0.0029	0.0051	0.0096	0.0177	0.0311	0.0501
315	F_{r1}	N	1600	2200	2900	3600	4500	5600	10900	13400	16100	17700	19800
	F_{r2}	N	4100	5200	9600	14400	20000	25700	31900	37600	46100	50400	60700
	J_1	kgm ²	0.0001	0.0005	0.0007	0.0009	0.0018	0.0029	0.0051	0.0096	0.0177	0.0311	0.0501
355	F_{r1}	N	1600	2200	2900	3600	4500	5600	10900	13400	16100	17700	19800
	F_{r2}	N	4100	5200	9600	14400	20000	25700	31900	37600	46100	50400	60700
	J_1	kgm ²	0.0001	0.0005	0.0007	0.0009	0.0018	0.0029	0.0051	0.0096	0.0177	0.0311	0.0501
400	F_{r1}	N	1600	2200	2900	3600	4500	5600	10900	13400	16100	17700	19800
	F_{r2}	N	4100	5200	9600	14400	20000	25700	31900	37600	46100	50400	60700
	J_1	kgm ²	0.0001	0.0005	0.0007	0.0009	0.0018	0.0029	0.0051	0.0096	0.0177	0.0311	0.0501



VELOCITÀ MASSIMA n_{1max} (min⁻¹)

MAXIMUM SPEED n_{1max} (min⁻¹)

Riduttori ad assi paralleli
Lubrificazione a sbattimento

Helical units
Splash lubrication

PA	10	20	30	40	50	60	70	80	90	100	110
i_N											
1.12	2000	1750	1500	1250	1250	1000	1000	750	750	750	500
1.25	2000	1750	1500	1500	1250	1250	1000	1000	750	750	500
1.4	2000	2000	1750	1500	1250	1250	1000	1000	750	750	750
1.6	2500	2000	1750	1750	1500	1250	1250	1000	1000	750	750
1.8	2500	2000	2000	1750	1500	1500	1250	1000	1000	1000	750
2	3000	2500	2000	2000	1750	1500	1500	1250	1000	1000	750
2.25	3000	2500	2500	2000	1750	1500	1500	1250	1250	1000	1000
2.5	3000	3000	2500	2000	2000	1750	1500	1500	1250	1000	1000
2.8	3500	3000	2500	2500	2000	2000	1750	1500	1250	1250	1000
3.15	3500	3500	3000	2500	2500	2000	2000	1750	1500	1250	1250
3.55	3500	3500	3000	3000	2500	2500	2000	1750	1500	1500	1250
4	3500	3500	3500	3000	3000	2500	2500	2000	1750	1500	1500
4.5	3500	3500	3500	3500	3000	3000	2500	2000	2000	1750	1500
5	3500	3500	3500	3500	3500	3000	3000	2500	2000	2000	1750
5.6	3500	3500	3500	3500	3500	3000	3000	2500	2500	2000	2000

PB	10	20	30	40	50	60	70	80	90	100	110
i_N											
6.3	3000	3000	2500	2500	2000	1750	1500	1500	1250	1250	1000
7.1	3500	3000	2500	2500	2500	2000	1750	1500	1250	1250	1250
8	3500	3500	3000	2500	2500	2000	2000	1750	1500	1250	1250
9	3500	3500	3000	3000	2500	2500	2000	1750	1500	1500	1250
10	3500	3500	3500	3000	2500	2500	2000	2000	1750	1500	1500
11.2	3500	3500	3500	3000	3000	2500	2500	2000	2000	1500	1500
12.5	3500	3500	3500	3500	3500	3000	2500	2500	2000	1750	1750
14	3500	3500	3500	3500	3500	3000	3000	2500	2000	2000	1750
16	3500	3500	3500	3500	3500	3500	3000	3000	2500	2000	2000
18	3500	3500	3500	3500	3500	3500	3000	3000	2500	2500	2000
20	3500	3500	3500	3500	3500	3500	3500	3000	3000	2500	2500
22.5			3500			3500	3500	3500	3000	3000	2500

PC	10	20	30	40	50	60	70	80	90	100	110
i_N											
22.5	3500	3500		3000	2500						
25	3500	3500	3000	3000	3000	2500	2000	2000	1500	1500	1500
28	3500	3500	3500	3000	3000	2500	2000	2000	1750	1500	1500
31.5	3500	3500	3500	3500	3000	2500	2500	2000	1750	1750	1500
35.5	3500	3500	3500	3500	3500	3000	2500	2500	2000	1750	1750
40	3500	3500	3500	3500	3500	3000	3000	2500	2000	2000	1750
45	3500	3500	3500	3500	3500	3500	3000	2500	2500	2000	2000
50	3500	3500	3500	3500	3500	3500	3000	3000	2500	2500	2000
56	3500	3500	3500	3500	3500	3500	3500	3000	2500	2500	2500
63	3500	3500	3500	3500	3500	3500	3500	3500	3000	2500	2500
71	3500	3500	3500	3500	3500	3500	3500	3500	3000	3000	3000
80	3500	3500	3500	3500	3500	3500	3500	3500	3500	3000	3000
90	3500	3500	3500	3500	3500	3500	3500	3500	3500	3500	3500
100	3500	3500	3500	3500		3500	3500	3500	3500	3500	3500
112										3500	

PD	10	20	30	40	50	60	70	80	90	100	110
i_N											
100					3500						
112	3500	3500	3500	3500	3500	3500	3000	2500	2500		2000
125	3500	3500	3500	3500	3500	3500	3000	3000	2500	2000	2000
140	3500	3500	3500	3500	3500	3500	3500	3000	2500	2500	2000
160	3500	3500	3500	3500	3500	3500	3500	3500	3000	2500	2500
180	3500	3500	3500	3500	3500	3500	3500	3500	3000	3000	2500
200	3500	3500	3500	3500	3500	3500	3500	3500	3000	3000	2500
225	3500	3500	3500	3500	3500	3500	3500	3500	3500	3000	3000
250	3500	3500	3500	3500	3500	3500	3500	3500	3500	3500	3000
280	3500	3500	3500	3500	3500	3500	3500	3500	3500	3500	3500
315	3500	3500	3500	3500	3500	3500	3500	3500	3500	3500	3500
355	3500	3500	3500	3500	3500	3500	3500	3500	3500	3500	3500
400	3500	3500	3500	3500	3500	3500	3500	3500	3500	3500	3500
450	3500	3500	3500	3500		3500	3500	3500	3500	3500	3500
500	3500	3500	3500			3500	3500	3500	3500	3500	3500



VELOCITÀ MASSIMA n_{1max} (min⁻¹)

MAXIMUM SPEED n_{1max} (min⁻¹)

Riduttori ad assi paralleli
Lubrificazione forzata

Helical units
Forced lubrication

PA	10	20	30	40	50	60	70	80	90	100	110
i_N											
1.12	3000	2500	2500	2000	2000	1750	1500	1250	1250	1000	1000
1.25	3500	3000	2500	2500	2000	1750	1750	1500	1250	1250	1000
1.4	3500	3000	3000	2500	2000	2000	1750	1500	1500	1250	1000
1.6	3500	3500	3000	2500	2500	2000	2000	1750	1500	1250	1250
1.8	3500	3500	3000	3000	2500	2000	2000	1750	1500	1500	1250
2	3500	3500	3500	3000	2500	2500	2000	2000	1750	1500	1250
2.25	3500	3500	3500	3500	3000	2500	2500	2000	2000	1750	1500
2.5	3500	3500	3500	3500	3000	3000	2500	2000	2000	1750	1500
2.8	3500	3500	3500	3500	3500	3000	3000	2500	2000	2000	1750
3.15	3500	3500	3500	3500	3500	3500	3000	2500	2500	2000	2000
3.55	3500	3500	3500	3500	3500	3500	3500	3000	2500	2500	2000
4	3500	3500	3500	3500	3500	3500	3500	3000	3000	2500	2500
4.5	3500	3500	3500	3500	3500	3500	3500	3500	3000	3000	2500
5	3500	3500	3500	3500	3500	3500	3500	3500	3500	3000	2500
5.6	3500	3500	3500	3500	3500	3500	3500	3500	3500	3500	3000

PB	10	20	30	40	50	60	70	80	90	100	110
i_N											
6.3	3500	3500	3500	3500	3500	3000	2500	2500	2000	1750	1750
7.1	3500	3500	3500	3500	3500	3000	3000	2500	2000	2000	1750
8	3500	3500	3500	3500	3500	3500	3000	2500	2500	2000	2000
9	3500	3500	3500	3500	3500	3500	3500	3000	2500	2500	2000
10	3500	3500	3500	3500	3500	3500	3500	3000	3000	2500	2500
11.2	3500	3500	3500	3500	3500	3500	3500	3500	3000	2500	2500
12.5	3500	3500	3500	3500	3500	3500	3500	3500	3000	3000	2500
14	3500	3500	3500	3500	3500	3500	3500	3500	3500	3000	3000
16	3500	3500	3500	3500	3500	3500	3500	3500	3500	3500	3000
18	3500	3500	3500	3500	3500	3500	3500	3500	3500	3500	3500
20	3500	3500	3500	3500	3500	3500	3500	3500	3500	3500	3500
22.5			3500			3500	3500	3500	3500	3500	3500

PC	10	20	30	40	50	60	70	80	90	100	110
i_N											
22.5	3500	3500		3500	3500						
25	3500	3500	3500	3500	3500	3500	3500	3000	2500	2500	2000
28	3500	3500	3500	3500	3500	3500	3500	3000	2500	2500	2500
31.5	3500	3500	3500	3500	3500	3500	3500	3500	3000	2500	2500
35.5	3500	3500	3500	3500	3500	3500	3500	3500	3000	3000	3000
40	3500	3500	3500	3500	3500	3500	3500	3500	3500	3000	3000
45	3500	3500	3500	3500	3500	3500	3500	3500	3500	3500	3000
50	3500	3500	3500	3500	3500	3500	3500	3500	3500	3500	3500
56	3500	3500	3500	3500	3500	3500	3500	3500	3500	3500	3500
63	3500	3500	3500	3500	3500	3500	3500	3500	3500	3500	3500
71	3500	3500	3500	3500	3500	3500	3500	3500	3500	3500	3500
80	3500	3500	3500	3500	3500	3500	3500	3500	3500	3500	3500
90	3500	3500	3500	3500	3500	3500	3500	3500	3500	3500	3500
100	3500	3500	3500	3500		3500	3500	3500	3500	3500	3500
112										3500	

PD	10	20	30	40	50	60	70	80	90	100	110
i_N											
100					3500						
112	3500	3500	3500	3500	3500	3500	3500	3500	3500		3000
125	3500	3500	3500	3500	3500	3500	3500	3500	3500	3500	3000
140	3500	3500	3500	3500	3500	3500	3500	3500	3500	3500	3500
160	3500	3500	3500	3500	3500	3500	3500	3500	3500	3500	3500
180	3500	3500	3500	3500	3500	3500	3500	3500	3500	3500	3500
200	3500	3500	3500	3500	3500	3500	3500	3500	3500	3500	3500
225	3500	3500	3500	3500	3500	3500	3500	3500	3500	3500	3500
250	3500	3500	3500	3500	3500	3500	3500	3500	3500	3500	3500
280	3500	3500	3500	3500	3500	3500	3500	3500	3500	3500	3500
315	3500	3500	3500	3500	3500	3500	3500	3500	3500	3500	3500
355	3500	3500	3500	3500	3500	3500	3500	3500	3500	3500	3500
400	3500	3500	3500	3500	3500	3500	3500	3500	3500	3500	3500
450	3500	3500	3500	3500		3500	3500	3500	3500	3500	3500
500	3500	3500	3500			3500	3500	3500	3500	3500	3500



VELOCITÀ MASSIMA n_{1max} (min⁻¹)

MAXIMUM SPEED n_{1max} (min⁻¹)

Riduttori ad assi ortogonali
Lubrificazione a sbattimento

Bevel-Helical units
Splash lubrication

RHB/RVB	10	20	30	40	50	60	70	80	90	100	110
i_N											
5	3500	3500	3000	2500	2500	2000	2000	1750	1500	1250	1250
5.6	3500	3500	3000	2500	2500	2000	2000	1750	1500	1250	1250
6.3	3500	3500	3000	2500	2500	2000	2000	1750	1500	1250	1250
7.1	3500	3500	3000	2500	2500	2000	2000	1750	1500	1250	1250
8	3500	3500	3000	2500	2500	2000	2000	1750	1500	1250	1250
9	3500	3500	3000	2500	2500	2000	2000	1750	1500	1250	1250
10	3500	3500	3000	2500	2500	2000	2000	1750	1500	1250	1250
11.2	3500	3500	3000	2500	2500	2000	2000	1750	1500	1250	1250
12.5	3500	3500	3500	3500	3500	3000	3000	2500	2500	2000	1750
14	3500	3500	3500	3500	3500	3000	3000	2500	2500	2000	1750
16	3500	3500	3500	3500	3500	3000	3000	2500	2500	2000	1750
18	3500	3500	3500	3500	3500	3000	3000	2500	2500	2000	1750

RHC/RVC	10	20	30	40	50	60	70	80	90	100	110
i_N											
20	3500	3500	3500	3500	3500	3000	2500	2500	2000	2000	1750
22.5	3500	3500	3500	3500	3500	3000	2500	2500	2000	2000	1750
25	3500	3500	3500	3500	3500	3000	2500	2500	2000	2000	1750
28	3500	3500	3500	3500	3500	3000	2500	2500	2000	2000	1750
31.5	3500	3500	3500	3500	3500	3000	2500	2500	2000	2000	1750
35.5	3500	3500	3500	3500	3500	3000	2500	2500	2000	2000	1750
40	3500	3500	3500	3500	3500	3000	2500	2500	2000	2000	1750
45	3500	3500	3500	3500	3500	3000	2500	2500	2000	2000	1750
50	3500	3500	3500	3500	3500	3500	3500	3500	3000	3000	2500
56	3500	3500	3500	3500	3500	3500	3500	3500	3000	3000	2500
63	3500	3500	3500	3500	3500	3500	3500	3500	3000	3000	2500
71	3500	3500	3500	3500	3500	3500	3500	3500	3000	3000	2500
80		3500		3500	3500	3500	3500	3500	3000	3000	2500

RHD/RVD	10	20	30	40	50	60	70	80	90	100	110
i_N											
80	3500		3500								
90	3500	3500	3500	3500	3500	3500	3500	3500	3000	2500	2500
100	3500	3500	3500	3500	3500	3500	3500	3500	3000	2500	2500
112	3500	3500	3500	3500	3500	3500	3500	3500	3000	2500	2500
125	3500	3500	3500	3500	3500	3500	3500	3500	3000	2500	2500
140	3500	3500	3500	3500	3500	3500	3500	3500	3000	2500	2500
160	3500	3500	3500	3500	3500	3500	3500	3500	3000	2500	2500
180	3500	3500	3500	3500	3500	3500	3500	3500	3000	2500	2500
200	3500	3500	3500	3500	3500	3500	3500	3500	3000	2500	2500
225	3500	3500	3500	3500	3500	3500	3500	3500	3500	3500	3500
250	3500	3500	3500	3500	3500	3500	3500	3500	3500	3500	3500
280	3500	3500	3500	3500	3500	3500	3500	3500	3500	3500	3500
315	3500	3500	3500	3500	3500	3500	3500	3500	3500	3500	3500
355	3500	3500	3500	3500	3500	3500	3500	3500	3500	3500	3500
400							3500		3500	3500	



VELOCITÀ MASSIMA n_{1max} (min⁻¹)

MAXIMUM SPEED n_{1max} (min⁻¹)

Riduttori ad assi ortogonali
Lubrificazione forzata

Bevel-Helical units
Forced lubrication

RHB/RVB	10	20	30	40	50	60	70	80	90	100	110
i_N											
5	3500	3500	3500	3500	3500	3500	3000	2500	2500	2000	2000
5.6	3500	3500	3500	3500	3500	3500	3000	2500	2500	2000	2000
6.3	3500	3500	3500	3500	3500	3500	3000	2500	2500	2000	2000
7.1	3500	3500	3500	3500	3500	3500	3000	2500	2500	2000	2000
8	3500	3500	3500	3500	3500	3500	3000	2500	2500	2000	2000
9	3500	3500	3500	3500	3500	3500	3000	2500	2500	2000	2000
10	3500	3500	3500	3500	3500	3500	3000	2500	2500	2000	2000
11.2	3500	3500	3500	3500	3500	3500	3000	2500	2500	2000	2000
12.5	3500	3500	3500	3500	3500	3500	3500	3500	3500	3000	3000
14	3500	3500	3500	3500	3500	3500	3500	3500	3500	3000	3000
16	3500	3500	3500	3500	3500	3500	3500	3500	3500	3000	3000
18	3500	3500	3500	3500	3500	3500	3500	3500	3500	3000	3000

RHC/RVC	10	20	30	40	50	60	70	80	90	100	110
i_N											
20	3500	3500	3500	3500	3500	3500	3500	3500	3500	3000	2500
22.5	3500	3500	3500	3500	3500	3500	3500	3500	3500	3000	2500
25	3500	3500	3500	3500	3500	3500	3500	3500	3500	3000	2500
28	3500	3500	3500	3500	3500	3500	3500	3500	3500	3000	2500
31.5	3500	3500	3500	3500	3500	3500	3500	3500	3500	3000	2500
35.5	3500	3500	3500	3500	3500	3500	3500	3500	3500	3000	2500
40	3500	3500	3500	3500	3500	3500	3500	3500	3500	3000	2500
45	3500	3500	3500	3500	3500	3500	3500	3500	3500	3000	2500
50	3500	3500	3500	3500	3500	3500	3500	3500	3500	3500	3500
56	3500	3500	3500	3500	3500	3500	3500	3500	3500	3500	3500
63	3500	3500	3500	3500	3500	3500	3500	3500	3500	3500	3500
71	3500	3500	3500	3500	3500	3500	3500	3500	3500	3500	3500
80		3500		3500	3500	3500	3500	3500	3500	3500	3500

RHD/RVD	10	20	30	40	50	60	70	80	90	100	110
i_N											
80	3500		3500								
90	3500	3500	3500	3500	3500	3500	3500	3500	3500	3500	3500
100	3500	3500	3500	3500	3500	3500	3500	3500	3500	3500	3500
112	3500	3500	3500	3500	3500	3500	3500	3500	3500	3500	3500
125	3500	3500	3500	3500	3500	3500	3500	3500	3500	3500	3500
140	3500	3500	3500	3500	3500	3500	3500	3500	3500	3500	3500
160	3500	3500	3500	3500	3500	3500	3500	3500	3500	3500	3500
180	3500	3500	3500	3500	3500	3500	3500	3500	3500	3500	3500
200	3500	3500	3500	3500	3500	3500	3500	3500	3500	3500	3500
225	3500	3500	3500	3500	3500	3500	3500	3500	3500	3500	3500
250	3500	3500	3500	3500	3500	3500	3500	3500	3500	3500	3500
280	3500	3500	3500	3500	3500	3500	3500	3500	3500	3500	3500
315	3500	3500	3500	3500	3500	3500	3500	3500	3500	3500	3500
355	3500	3500	3500	3500	3500	3500	3500	3500	3500	3500	3500
400							3500		3500	3500	



PESI (kg)

Riduttori ad assi paralleli

WEIGHTS (kg)

Helical units

	10	20	30	40	50	60	70	80	90	100	110
PA	72	120	164	237	324	450	616	915	1250	1490	2380
PB	81	138	166	250	390	540	753	955	1465	1810	2810
PC	96	165	228	309	438	591	814	1190	1520	2040	3280
PD	116	177	241	327	461	636	865	1298	1620	2400	3410

Riduttori ad assi ortogonali

Bevel-Helical units

	10	20	30	40	50	60	70	80	90	100	110
RHB/RVB	91	126	176	248	362	494	688	910	1320	1870	2680
RHC/RVC	106	126	206	294	360	569	785	1110	1510	2180	3080
RHD/RVD	110	159	225	312	436	618	873	1205	1626	2315	3350

QUANTITÀ DI OLIO (l)

Tutti i riduttori vengono di regola forniti senza olio. Nelle Tabelle sottostanti vengono forniti i quantitativi approssimativi per montaggio orizzontale. Per posizioni di montaggio diverse dalla 1 riempire fino al livello indicato dal tappo di livello o dall'asta di livello.

Non riempire al di sopra del livello onde evitare possibilità di perdite e surriscaldamenti.

LUBRICANT QUANTITIES (liters)

If not stated otherwise, all units are dispatched without oil. The approximate quantity of oil required for horizontal mounting is given in the tables below. For mounting positions different from position 1 unit should be filled to the level marked on the level plug or on the dipstick. Do not overfill the unit as this can cause leakage and overheating.

Riduttori ad assi paralleli

Helical units

	10	20	30	40	50	60	70	80	90	100	110
PA	2.8	3.9	5.4	7.3	9.8	13.8	19	26	37	52	72
PB	3.6	5	6.5	10	13	18	28	35	49	69	96
PC	4.5	6.3	8.1	13	17	26	36	52	73	102	145
PD	4.5	6.3	8.1	13	17	26	36	52	73	102	145

Riduttori ad assi ortogonali

Bevel-Helical units

	10	20	30	40	50	60	70	80	90	100	110
RHB/RVB	3.4	4.7	6.5	8.8	12	16.5	22.8	31	44.4	62	86.5
RHC/RVC	4.7	6.5	9	13	18	25	35	49	69	96	135
RHD/RVD	5.5	7.7	10.1	16.2	21	32.5	45	65	91	127	178



LUBRIFICAZIONE

Gradazione di viscosità ISO e AGMA

LUBRICATION

ISO & AGMA viscosity grade

Velocità - Speed n_2 (min ⁻¹)	Normative - Standard	Temperatura ambiente (°C) - Ambient temperature range (°C)		
		dalfrom -10 alto -15	dalfrom 0 alto +30	dalfrom +10 alto +50
Minore di/Under 100	ISO - AGMA	VG 68 2 EP	VG 150 4 EP	VG 220 5 EP
Maggiore di/Over 100	ISO - AGMA	VG 100 3 EP	VG 220 5 EP	VG 320 6 EP

Indicazioni valide per riduttore con raffreddamento naturale, o artificiale con ventola. In presenza di impianto esterno di raffreddamento e/o lubrificazione contattare il ns. ufficio tecnico.

Indications valid for reduction gears cooled naturally or artificially with a fan. When there is an external cooling and/or lubricating system please contact our technical office.

Oli minerali consigliati

Recommended mineral lubricants

Viscosità ISO a 40°C ISO Viscosity at 40°C (mm ² /s)	AGIP Blasia	BP Energol	MOBIL Mobilgear	SHELL Omala S2G	TEXACO Meropa	TOTAL Carter
VG 320	320	GR-XP 320	632	320	320	EP 320
VG 220	220	GR-XP 220	630	220	220	EP 220
VG 150	150	GR-XP 150	629	150	150	EP 150
VG 100	100	GR-XP 100	627	100	100	EP 100
VG 68	68	GR-XP 68	626	68	68	EP 68

Oli sintetici consigliati

Recommended synthetic lubricants

Viscosità ISO a 40°C ISO Viscosity at 40°C (mm ² /s)	BP Energol	CASTROL Tribol	KLUEBER EG4	MOBIL SHC
VG 320	EPX 320	1510/320	320	632
VG 220	EPX 220	1510/220	220	630
VG 150	HTX 150	1510/150	150	629
VG 68				626

Oli minerali: max. temperature di esercizio 90°C
Oli sintetici: max. temperatura di esercizio 100°C (110°C per brevi periodi).
Non miscelare oli sintetici di marche diverse

Mineral oil: max. running temperature 90°C
Synthetic oil: max. running temperature 100°C (110°C for short running)
Do not mix up different brands.

Intervallo di sostituzione dell'olio

Oil change interval (h)

TIPO TYPE	Temperatura olio - Oil temperature		
	65°C	80°C	90°C
Minerale Mineral	8000 ore / 24 mesi 8000 hours / 24 months	4000 ore / 18 mesi 4000 hours / 18 months	2000 ore / 12 mesi 2000 hours / 12 months
Sintetico Synthetic	20000 / 48 mesi 20000 hours / 48 months	15000 / 36 mesi 15000 hours / 36 months	10000 / 24 mesi 10000 hours / 24 months



STATO DI FORNITURA

Al ricevimento della merce controllare che corrisponda a quanto ordinato e che non abbia subito danni durante il trasporto.

Evitare di mettere in servizio riduttori danneggiati anche solo lievemente.

I riduttori sono verniciati esternamente con fondo epossidico e smalto sintetico RAL 9005 (nero intenso), che consentono ulteriori finiture con vernici sintetiche. Nel caso di impiego del riduttore in ambienti aggressivi occorre richiedere un'adeguata verniciatura.

Le estremità d'albero, alberi cavi, centraggi e superfici lavorate di collegamento vengono protette con grasso antiossidazione.

I riduttori vengono forniti privi di lubrificante, salvo diverse indicazioni contrattuali.

Qualora sia presente sul riduttore un dispositivo antiritorno o ventola di raffreddamento una freccia in prossimità dell'albero lento evidenzierà il senso di rotazione libera.

STOCCAGGIO

I riduttori devono essere conservati in ambienti secchi, puliti e privi di vibrazioni. Per evitare danneggiamenti a cuscinetti e tenute fare compiere un giro completo agli ingranaggi tramite l'albero veloce con periodicità semestrale. Per periodi di stoccaggio superiori ad un anno occorre sostituire il tappo di carico olio con uno senza valvola di sfiato e riempire completamente il riduttore di olio. Sostituire con periodicità semestrale il grasso nelle tenute e il protettivo sulle parti lavorate.

Per stoccaggio in ambienti aggressivi prevedere un'adeguata verniciatura. Proteggere inoltre le parti rotanti e le superfici lavorate con grasso idrorepellente e antiossidante. Per ambienti umidi o con forti escursioni termiche fornire il riduttore di pastiglie igroscopiche ed eseguire le verifiche sopracitate con maggiore frequenza. Proteggere il riduttore il più possibile da irraggiamento solare e intemperie. In quest'ultimo caso la protezione diventa necessaria.

Nel caso di inoperosità del riduttore per lungo tempo occorre proteggere tutte le parti lavorate, controllare e lubrificare i vari collegamenti, sostituire l'olio esausto con altro fresco dello stesso tipo.

Nel caso di scambiatori di calore acqua-olio occorre togliere i tubi di alimentazione dell'acqua e soffiare aria compressa per eliminarla dall'interno dei tubi stessi. Se lo scambiatore è del tipo ispezionabile si consiglia lo smontaggio del fascio tubiero.

INSTALLAZIONE

Accertarsi che la struttura sulla quale viene fissato il riduttore sia piana, livellata e opportunamente dimensionata per garantire la stabilità del fissaggio e l'assenza di vibrazioni. Per il fissaggio occorre sfruttare i fori presenti sui 4 lati della cassa con viti di adeguata lunghezza. Per fissaggi differenti consultare il ns. Ufficio Tecnico.

Per il sollevamento del riduttore utilizzare i fori passanti per il fissaggio presenti sulla cassa cercando di equilibrare le masse. Non sollevare mai il riduttore abbracciando estremità d'albero o motori flangiati o eventuali accessori applicati sul riduttore.

In presenza di ventole di raffreddamento occorre collocare il riduttore in posizione tale da garantire un buon flusso di aria.

Nel caso di fissaggio riduttore-macchina tramite flange di accoppiamento si raccomanda l'impiego di adesivi bloccanti per le viti di fissaggio.

In presenza di dispositivi antiritorno o ventole di raffreddamento assicurarsi a riduttore scollegato che il senso di rotazione del motore sia corretto. In caso contrario invertire la tensione del motore.

Con avviamenti a vuoto è necessario avere avviamenti dolci con correnti di spunto basse e sollecitazioni contenute. Nel caso si prevedano sovraccarichi di lunga durata, urti o pericoli di bloccaggio, installare giunti idraulici di sicurezza, unità di controllo o altri dispositivi simili.

N.B.: PRENDERE VISIONE DEI CONTENUTI DEL MANUALE DI INSTALLAZIONE E MANUTENZIONE CONSEGNATO CON I RIDUTTORI.



STATE OF SUPPLY

On receipt of goods, check these correspond to those ordered and that no damage has been caused during transport. Avoid using even only slightly damaged gear units.

The gear units are coated on the outside with epoxy primer and synthetic enamel RAL 9005 (jet black), which permit further finishes with synthetic paints. If the gear units are used in aggressive environments, ask for adequate painting to be provided.

The shaft ends, hollow shafts, centrings and machined connecting surfaces are protected with anti-oxidisation grease. The gear units are supplied without lubricant, unless otherwise contractually agreed.

If the gear unit features a backstop device or cooling fan, an arrow near the low-speed shaft indicates the direction of free rotation.

STORAGE

The gear units must be stored in dry, clean and vibration-free environments. To avoid damaging bearings and seals have the gears perform one complete revolution by means of the high-speed shaft every six months. For storage periods of over one year, the oil filling cap must be replaced with another without breather valve and the gear unit must be completely filled with oil. Every six months, change the grease in the seals and the protective substance on the machined parts.

The gear unit must be adequately painted if stored in an aggressive environment. Also protect the rotating parts and machined surfaces with water-repellent and anti-oxidising grease. In the case of damp environments or where temperature fluctuations are strong, hygroscopic tablets should be used and all the above inspections made more frequently. Protect the gear unit as best as possible from sunrays and weather conditions. In the latter case, protection is mandatory.

If the gear unit is not used for long periods of time, all the machined parts should be protected.

Check and lubricate the various connections, change the old oil with new oil of the same type.

In the case of water-oil heat exchangers, the water supply pipes must be removed and cleaned with compressed air, to remove any water inside the pipes. If the exchanger is of the type that can be inspected, it is best to dismantle the pipe nest.

INSTALLATION

Make sure the structure to which the gear unit is fastened is flat, level and suitably sized to ensure stability and the absence of vibrations. To fasten, use the holes on the 4 sides of the casing and screws of suitable length. For other fastening requirements, contact our Technical Dept.

To lift the gear unit, use the fastening through holes on the casing and try and distribute weight properly. Never lift the gear unit by means of the shaft ends or flanged motors or any accessories fitted to the gear unit.

If cooling fans are fitted, the gear unit must be placed in such a position as to ensure a proper flow of air.

If the gear unit-machine fastening is by means of coupling flanges, it is best to use locking adhesives for the fastening screws.

If backstop devices or cooling fans are fitted, make sure, with the gear unit disconnected, that the direction of motor rotation is correct. If it is not, switch over the motor voltage. Idle start-ups must be gentle with low breakaway currents and reduced stress. If lengthy overloads, knocks or blockage hazards are expected, fit safety hydraulic couplings, control units or other similar devices.

NOTE: INSPECT THE CONTENTS OF THE INSTALLATION AND MAINTENANCE MANUAL PROVIDED WITH THE GEAR UNITS.

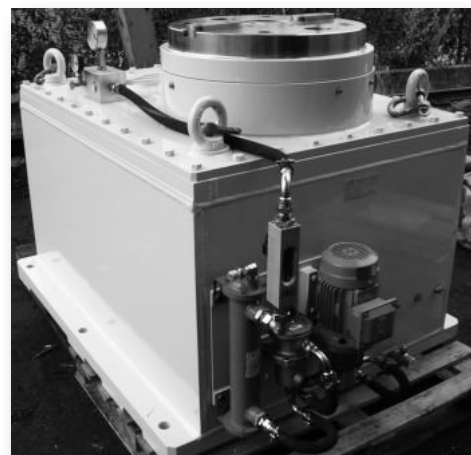
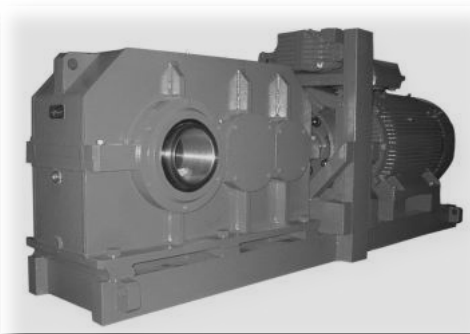
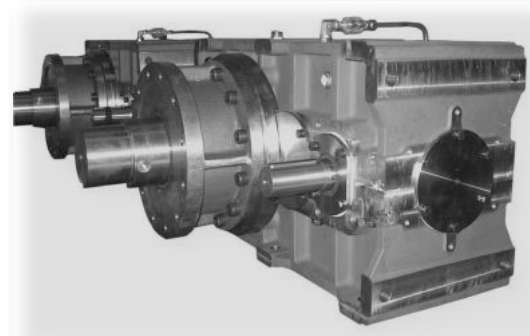
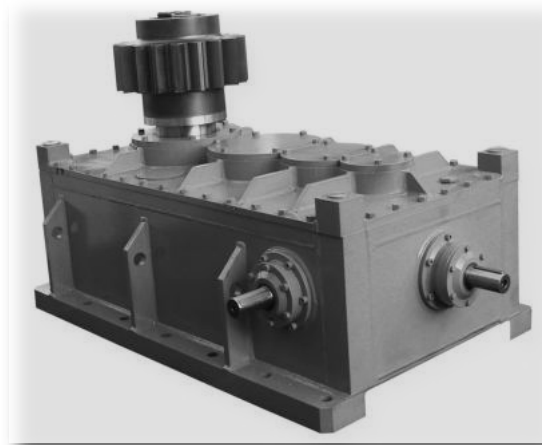
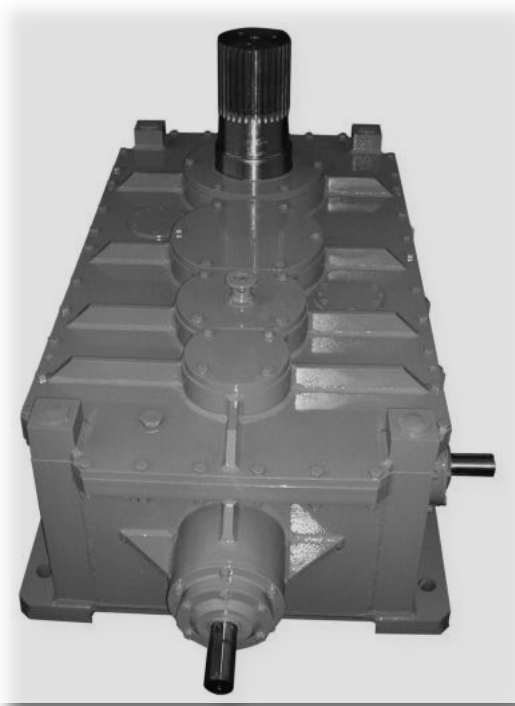

Su richiesta, Reggiana Riduttori è in grado di realizzare riduttori ad assi paralleli ed ortogonali speciali.
On request, Reggiana Riduttori produces customized helical and bevel-helical units.

C400-1500-00



REGGIANA RIDUTTORI S.r.l.

Via Martiri di Marzabotto,7
42020 S. Polo d'Enza (RE) ITALY
tel. +39.0522.259111 - fax +39.0522.874321
info@reggianariduttori.com
www.reggianariduttori.com